

GEMÜ 4232

Travel sensor for linear actuators



Features

- Optional equipment protection by intrinsic safety (Ex i) for use in zones 1, 2, 21, 22
- Optional equipment protection increased safety (Ex e) in combination with non-incendive protection (Ex n) and (dust) protection by enclosure (Ex t) for use in Zones 2, 22
- Easy fitting to GEMÜ linear actuators
- Compact, solid housing
- Durable
- Can be retrofitted to GEMÜ valves or third-party actuators
- Technically advanced and proven construction

Description

The GEMÜ 4232 travel sensor is intended for the attachment to valves with linear actuators and is used to determine the valve position. It is used as a travel sensor for the GEMÜ 1434 μ Pos, GEMÜ 1435 ePos and GEMÜ 1436 cPos intelligent positioners, which can be connected using either the open cable ends or an M12 cable plug.

Technical specifications

- **Ambient temperature:** -10 to 80 °C
- **Valve stroke** 0 to 75 mm
- **Protection class:** IP 64. IP 65

Technical data depends on the respective configuration



Product description

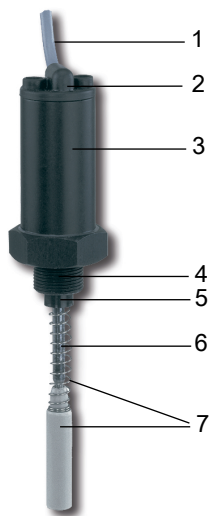

Item	Name	Materials
1	Cable	LIYY
2	Cover	Depending on design, anodized aluminium, PVDF or PP
3	Housing	Depending on design, anodized aluminium, PVDF or PP
4	Threaded piece	Depending on design, anodized aluminium (SS for explosion-protected design), PVDF or PP
5	Bushing with internal lip ring	Bushing PP, lip ring PUR
6	Spindle	1.4104
7	Mounting kit	Material depending on design (specific to valve)

Availability

	Code	Special version Explosion protection Ex i (code X) or Ex e, n, t (code Z)
Housing material ¹⁾	05	-
	14	X
	20	-

1) **Housing material**

Code 05: PP, polypropylene

Code 14: Anodized aluminium

Code 20: PVDF, polyvinylidene fluoride

Order data

The order data provide an overview of standard configurations.

Please check the availability before ordering. Other configurations available on request.

The travel length depends on the necessary mounting kit.

Note: A valve specific mounting kit is required for assembly. For designing the mounting kit, the valve type, nominal size, control function and actuator size must be stated.

Order codes

1 Type	Code
Travel sensor for linear actuators	4232

2 Fieldbus	Code
Without	000

3 Accessory	Code
Accessory	Z

4 Housing material	Code
PP, polypropylene	05
Anodized aluminium	14
PVDF, polyvinylidene fluoride	20

5 Travel length	Code
Potentiometer, 30 mm length	030
Potentiometer, 50 mm length	050
Potentiometer, 75 mm length	075

6 Cable length	Code
2 m cable, 3-pin	02M0
5 m cable, 3-pin	05M0
10 m cable, 3-pin	10M0
20 m cable, 3-pin	20M0

7 Cable connection	Code
Open wires with cable ends	0000
M12 cable connector, straight	4001

8 Special version	Code
Without	
ATEX/IECEX ib for zone 1/21 intrinsic safety ignition protection	X
ATEX nC,eC/tC for zone 2/22 Ex eC, nC, tC ignition protection	Z

Order example

Ordering option	Code	Description
1 Type	4232	Travel sensor for linear actuators
2 Fieldbus	000	Without
3 Accessory	Z	Accessory
4 Housing material	14	Anodized aluminium
5 Travel length	030	Potentiometer, 30 mm length
6 Cable length	05M0	5 m cable, 3-pin
7 Cable connection	0000	Open wires with cable ends
8 Special specification		Without

Technical data

Temperature

Ambient temperature: -10 – 80 °C
Special version X and Z: -10 to 70 °C

Storage temperature: -10 – 80 °C

Product compliance

Explosion protection: ATEX (2014/34/EU) and IECEx, order code special version X or Z

Code X marking: **Intrinsic safety (Ex i) ignition protection**

ATEX

Gas:  II 2G Ex ib IIB T4 Gb

Dust:  II 2D Ex ib IIIC T130 °C Db

Certificate: IBExU20ATEX1045

IECEx

Gas: Ex ib IIB T4 Gb

Dust: Ex ib IIIC T130 °C Db

Certificate: IECEx IBE 20.0027 X

Operation in potentially explosive areas only in conjunction with a safety barrier complying with ATEX which is designed for operating passive resistor elements or potentiometers and for which separate operating instructions apply.

In addition, the supplied limit resistor must be installed in the wiper cable between the safety barrier and travel sensor.

Code Z marking: **Increased safety (Ex e) ignition protection in combination with non-incendive (Ex n) and (dust) protection by enclosure (Ex t)**

ATEX

Gas:  II 3G Ex ec nC IIC T4 Gc X

Staub:  II 3D Ex tc IIIC T80°C Dc X

Zertifikat: IBExU20ATEX1045

IECEx

Gas: Ex ec nC IIC T4 Gc X

Dust: Ex tc IIIC T80°C Dc X

Certificate: IECEx IBE 20.0027 X

Potential equalisation: **Special version code X and Z**

The travel sensor must be integrated into the system's potential equalization via the pre-assembled earthing kit.

The potential equalization connection's maximum permissible resistance limit value is defined as $R \leq 100 \Omega$.

During the plant-specific maintenance cycle, the potential equalization connection must be checked to ensure that it has been connected correctly and that the maximum resistance limit value has not been exceeded.

Mechanical data

Protection class: IP 64 in accordance with EN 60529 – housing material anodized aluminium (code 14)
 IP 65 in accordance with EN 60529 – housing material PVDF, PP (code 20)

Weight:

Travel sensor length	Material		
	Aluminium (code 14)		PP (code 05) PVDF (code 20)
	Standard	Special version (code X and Z)	Standard
30 mm (Code 030)	110	170	140
50 mm (Code 050)	125	180	150
75 mm (Code 075)	140	190	160

Weight in g
 Weight specifications include 2 m of cable with open ends and cable ends.
 Additional weight in each case:
 25 g per additional metre of cable
 20 g with M12 cable connector (cable connection code 4001)

Service life: 10 x 10⁶ operations

Installation position: Optional

Min. stroke: Dependent on the connected device

Max. stroke:

Travel sensor version		
Code 030	Code 050	Code 075
30 mm	50.2 mm	74.4 mm

Electrical data

Duty cycle: Continuous duty

Electrical connection: Open wires with multicore cable ends (code 0000)
M12 cable plug A-coded, straight, 5-pin, plastic (code 4001)

Supply voltage U_v : max. 42 V DC
(does not apply to code X special version – the intrinsically safe characteristic values apply here)
The travel sensor is generally supplied by the connected positioners (GEMÜ 1434, 1435 or 1436).

	Travel sensor version		
	Code 030	Code 050	Code 075
Linearity:	± 0.2 %	± 0.25 %	± 0.1 %
Repeatability:	> 10 µm	> 10 µm	> 10 µm
Nominal resistance:	3 kΩ	5 kΩ	5 kΩ

Safety-relevant values: Special version code X

A)

$U_i = 30 \text{ V}$

$I_i = 100 \text{ mA}$

$P_i = 700 \text{ mW}$

These values refer to the two supply cables (white and green wires), which need to be protected with a two-channel safety barrier.

B)

$U_i = 16 \text{ V}$

$I_i = 200 \text{ mA}$

$P_i = 600 \text{ mW}$

These values refer to the wiper cable (brown wire), which needs to be protected with a single-channel safety barrier. The supplied limit resistor must also be wired.

Dimensions

Housing material aluminium

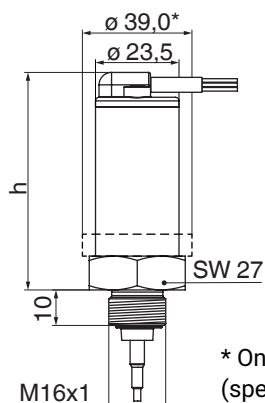

* Only explosion-protected designs
(special version X and Z)

Travel sensor length (code)	h	
	Standard	ATEX design (code Z)
030	62.2	67.2
050	84.2	89.2
075	109.2	114.2

Dimensions in mm

Housing material PVDF or PP

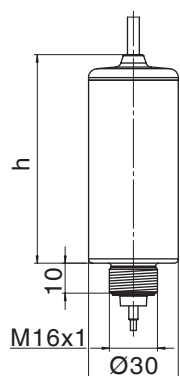

Travel sensor length (code)	h
030	69.6
050	91.6
075	116.6

Dimensions in mm

Electrical connection

Design with open wires with cable ends (code 0000)

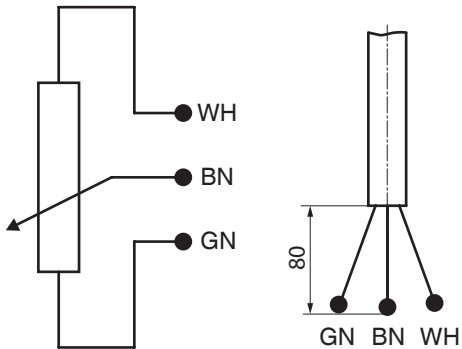

This design is suitable for connecting to the GEMÜ 1435 positioner (except the GEMÜ 1435 design with M12 cable connector).

Design with M12 cable connector (code 4001)

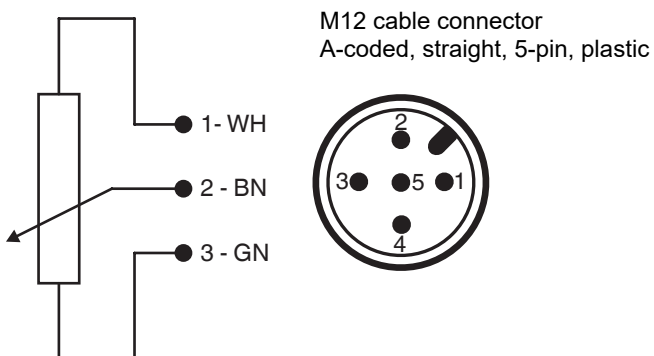

This design is suitable for connecting to the GEMÜ 1434, 1436 or 1435 positioner with the M12 cable connector design.

For special versions X and Z:

The M12 connector must only be connected in the safe area (outside the potentially explosive zone). The enclosed M12 cable connector is only intended for connection to the positioner (the positioners (GEMÜ 1434, 1435 and 1436) are not explosion-protected and must only be installed outside of the potentially explosive zone).

Special version (code X)

Potential equalisation:

The electrical connection of the travel sensor to the positioner must be routed via safety barriers (the supplied limit resistor also must be wired) – see wiring diagram.

In order to wire the safety barriers appropriately, the connection cable for the travel sensor can be cut to length at the point at which the safety barriers are being installed (generally a DIN rail) and the end piece including the fitted M12 cable connector can be used to continue wiring from the safety barriers to the installation position for the positioner.

Wiring diagram

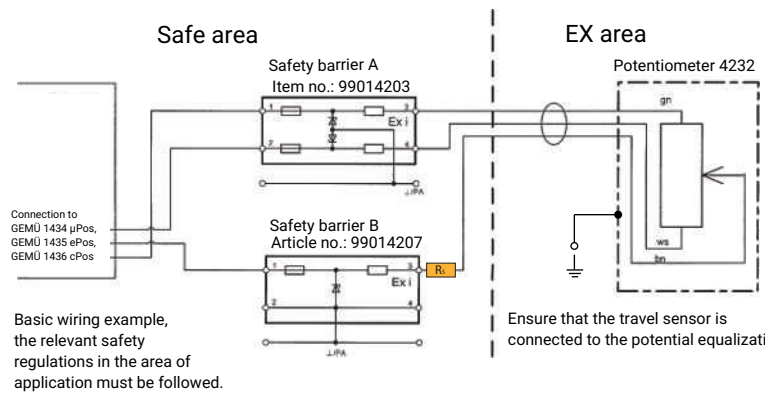



GEMÜ Gebr. Müller Apparatebau GmbH & Co. KG
Fritz-Müller-Straße 6-8, 74653 Ingelfingen-Criesbach, Germany
Phone +49 (0) 7940 1230 · info@gemue.de
www.gemu-group.com