

GEMÜ R677

Manually operated diaphragm valve

EN

Operating instructions



further information
webcode: GW-R677



All rights including copyrights or industrial property rights are expressly reserved.

Keep the document for future reference.

© GEMÜ Gebr. Müller Apparatebau GmbH & Co. KG
14.03.2024

Contents

1	General information	4
1.1	Information	4
1.2	Symbols used	4
1.3	Definition of terms	4
1.4	Warning notes	4
2	Safety information	5
3	Product description	5
4	Correct use	6
5	Order data	7
5.1	Order codes	7
5.2	Order example	8
6	Technical data	9
6.1	Medium	9
6.2	Temperature	9
6.3	Pressure	9
6.4	Product conformity	10
6.6	Mechanical data	11
7	Dimensions	12
7.1	Actuator dimensions	12
7.2	Body dimensions	13
7.3	Valve body mounting	23
8	Delivery	24
9	Transport	24
10	Storage	24
11	Installation in piping	24
11.1	Preparing for installation	24
11.2	Installation with butt weld spigots	25
11.3	Installation with union ends	25
11.4	Installation with flanged connection	25
11.5	Installation with solvent cement spigots	26
11.6	After the installation	26
12	Commissioning	26
13	Operation	27
14	Troubleshooting	28
15	Inspection and maintenance	29
15.1	Removing the actuator	29
15.2	Removing the diaphragm	29
15.3	Mounting the diaphragm	29
15.4	Mounting the actuator	30
15.5	Sectional drawing and spare parts	31
16	Disposal	31
17	Returns	31
18	EU Declaration of Conformity in accordance with 2014/68/EU (Pressure Equipment Directive)	32

1 General information

1.1 Information

- The descriptions and instructions apply to the standard versions. For special versions not described in this document the basic information contained herein applies in combination with any additional special documentation.
- Correct installation, operation, maintenance and repair work ensure faultless operation of the product.
- Should there be any doubts or misunderstandings, the German version is the authoritative document.
- Contact us at the address on the last page for staff training information.

1.2 Symbols used

The following symbols are used in this document:

Symbol	Meaning
●	Tasks to be performed
▶	Response(s) to tasks
-	Lists

1.3 Definition of terms

Working medium

The medium that flows through the GEMÜ product.

Diaphragm size

Uniform seat size of GEMÜ diaphragm valves for different nominal sizes.

1.4 Warning notes



Wherever possible, warning notes are organised according to the following scheme:

SIGNAL WORD	
Possible symbol for the specific danger	<p>Type and source of the danger</p> <ul style="list-style-type: none"> ▶ Possible consequences of non-observance. ● Measures for avoiding danger.





Warning notes are always marked with a signal word and sometimes also with a symbol for the specific danger.

The following signal words and danger levels are used:

⚠ DANGER	
	<p>Imminent danger!</p> <ul style="list-style-type: none"> ▶ Non-observance can cause death or severe injury.
⚠ WARNING	
	<p>Potentially dangerous situation!</p> <ul style="list-style-type: none"> ▶ Non-observance can cause death or severe injury.

⚠ CAUTION	
	<p>Potentially dangerous situation!</p> <ul style="list-style-type: none"> ▶ Non-observance can cause moderate to light injury.
NOTICE	
	<p>Potentially dangerous situation!</p> <ul style="list-style-type: none"> ▶ Non-observance can cause damage to property.

The following symbols for the specific dangers can be used within a warning note:

Symbol	Meaning
	Danger of explosion!
	Corrosive chemicals!
	Hot plant components!
	Handwheel can become hot during operation!

2 Safety information

The safety information in this document refers only to an individual product. Potentially dangerous conditions can arise in combination with other plant components, which need to be considered on the basis of a risk analysis. The operator is responsible for the production of the risk analysis and for compliance with the resulting precautionary measures and regional safety regulations.

The document contains fundamental safety information that must be observed during commissioning, operation and maintenance. Non-compliance with these instructions may cause:

- Personal hazard due to electrical, mechanical and chemical effects.
- Hazard to nearby equipment.
- Failure of important functions.
- Hazard to the environment due to the leakage of dangerous substances.

The safety information does not take into account:

- Unexpected incidents and events, which may occur during installation, operation and maintenance.
- Local safety regulations which must be adhered to by the operator and by any additional installation personnel.

Prior to commissioning:

1. Transport and store the product correctly.
2. Do not paint the bolts and plastic parts of the product.
3. Carry out installation and commissioning using trained personnel.
4. Provide adequate training for installation and operating personnel.
5. Ensure that the contents of the document have been fully understood by the responsible personnel.
6. Define the areas of responsibility.
7. Observe the safety data sheets.
8. Observe the safety regulations for the media used.

During operation:

9. Keep this document available at the place of use.
10. Observe the safety information.
11. Operate the product in accordance with this document.
12. Operate the product in accordance with the specifications.
13. Maintain the product correctly.
14. Do not carry out any maintenance work and repairs not described in this document without consulting the manufacturer first.

In cases of uncertainty:

15. Consult the nearest GEMÜ sales office.

3 Product description

3.1 Construction

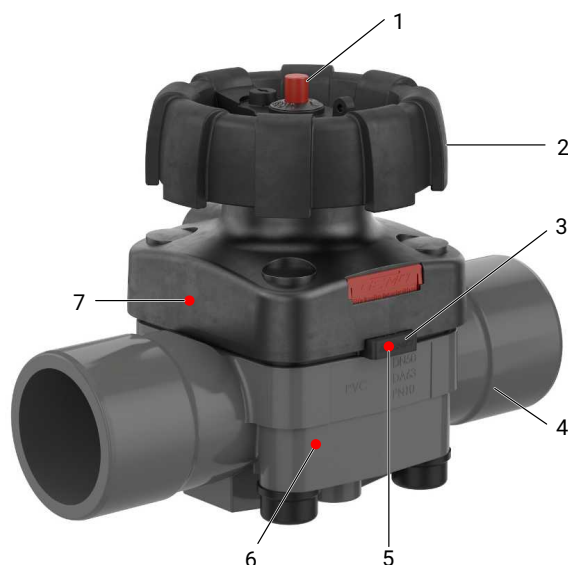

Item	Name	Materials
1	Optical position indicator	PP-H red
2	Actuator	PP- H 30% glass fibre reinforced
3	Diaphragm	NBR, FKM, EPDM, PTFE / EPDM one-piece, PTFE / EPDM two-piece
4	Valve body	PVC-U, grey ABS PP, reinforced PVDF Inliner PP-H, grey / outliner PP, reinforced Inliner PVDF / outliner PP, reinforced
5	CONEXO diaphragm RFID chip (see Conexo information)	
6	CONEXO body RFID chip (see Conexo information)	
7	CONEXO actuator RFID chip (see Conexo information)	

3.2 Function

The product is designed for use in piping. It controls a flowing medium by manual operation. The valve body and the diaphragm are available in various designs as shown in the data-sheet.

4 Correct use

 DANGER	
	Danger of explosion! <ul style="list-style-type: none">▶ Risk of death or severe injury● Do not use the product in potentially explosive zones.

 WARNING	
Improper use of the product! <ul style="list-style-type: none">▶ Risk of severe injury or death▶ Manufacturer liability and guarantee will be void.● Only use the product in accordance with the operating conditions specified in the contract documentation and in this document.	

The product is designed for installation in piping systems and for controlling a working medium.

The product is not intended for use in potentially explosive areas.

- Use the product in accordance with the technical data.

5 Order data

The order data provide an overview of standard configurations.

Please check the availability before ordering. Other configurations available on request.

Order codes

1 Type	Code
Diaphragm valve, manually operated, plastic handwheel, optical position indicator	R677

2 DN	Code
DN 15	15
DN 20	20
DN 25	25
DN 32	32
DN 40	40
DN 50	50
DN 65	65
DN 80	80
DN 100	100

3 Body configuration	Code
2/2-way body	D

4 Connection type	Code
Spigot	
Spigot DIN	0
Spigot for IR butt welding	20
Spigot – inch, for welding or solvent cementing, depending on the body material	30
Body with threaded spigots for unions	7X
Union end	
Union end with insert (socket) – DIN	7
Union end with insert (Rp threaded socket) – DIN	7R
Union end with inch insert – BS (socket)	33
Union end with inch insert – ASTM (socket)	3M
Union end with insert – JIS (socket)	3T
Union end with insert (for IR butt welding) – DIN	78
Flange	
Flange EN 1092, PN 10, form B, face-to-face dimension FTF EN 558 series 1, ISO 5752, basic series 1	4
Flange ANSI Class 125/150 RF, face-to-face dimension FTF EN 558 series 1, ISO 5752, basic series 1, length only for body configuration D	39

5 Valve body material	Code
PVC-U, grey	1
ABS	4
PP, reinforced	5
PVDF	20
Inliner PP-H, grey, outliner PP, reinforced	71
Inliner PVDF/outliner PP, reinforced	75

6 Diaphragm material	Code
Elastomer	
NBR	2
FKM	4
EPDM	17
EPDM	29
PTFE	
PTFE/EPDM one-piece	54
PTFE/EPDM two-piece	5M
Note: The PTFE/EPDM diaphragm (code 5M) is available from diaphragm size 25.	

7 Control function	Code
Manually operated	0
Manually operated, with lockable handwheel	L

8 Actuator version	Code
with connection thread for electrical position indicator	
Actuator size EDZ (diaphragm size 20)	EDZ
Actuator size EFZ (diaphragm size 20)	EFZ
Actuator size FDZ (diaphragm size 25)	FDZ
Actuator size HDZ (diaphragm size 40)	HDZ
Actuator size KDZ (diaphragm size 50)	KDZ
Actuator size MDZ (diaphragm size 80)	MDZ
Actuator size NDZ (diaphragm size 100)	NDZ
without connection thread for electrical position indicator	
Actuator size ED (diaphragm size 20)	ED
Actuator size EF (diaphragm size 20)	EF
Actuator size FD (diaphragm size 25)	FD
Actuator size HD (diaphragm size 40)	HD
Actuator size KD (diaphragm size 50)	KD

9 Special version	Code
NSF 61 water approval	N

10 CONEXO	Code
Without	
Integrated RFID chip for electronic identification and traceability	C

Order example

Ordering option	Code	Description
1 Type	R677	Diaphragm valve, manually operated, plastic handwheel, optical position indicator
2 DN	15	DN 15
3 Body configuration	D	2/2-way body
4 Connection type	7	Union end with insert (socket) – DIN
5 Valve body material	1	PVC-U, grey
6 Diaphragm material	17	EPDM
7 Control function	0	Manually operated
8 Actuator version	EDZ	Actuator size EDZ (diaphragm size 20)
9 Special version	N	NSF 61 water approval
10 CONEXO	C	Integrated RFID chip for electronic identification and traceability

6 Technical data

6.1 Medium

Working medium: Corrosive, inert, gaseous and liquid media which have no negative impact on the physical and chemical properties of the body and diaphragm material.

6.2 Temperature

Ambient temperature:

Valve body material	
PVC-U, grey (code 1)	10 – 50 °C
ABS (code 4)	-10 – 50 °C
PP, reinforced (code 5)	5 – 50 °C
PVDF (code 20)	-10 – 50 °C
Inliner PP-H grey / outliner PP, reinforced (code 71)	5 – 50 °C
Inliner PVDF / outliner PP, reinforced (code 75)	-5 – 50 °C

Storage temperature: 10 – 40 °C

6.3 Pressure

Operating pressure:

MG	DN	Diaphragm materials	
		Elastomer	PTFE
20	15	0 - 10	0 - 10
	20	0 - 10	0 - 10
	25	0 - 10	0 - 10
25	32	0 - 10	0 - 10
40	40	0 - 10	0 - 10
	50	0 - 10	0 - 10
50	65	0 - 10	0 - 10
80	80	0 - 10	0 - 6
100	100	0 - 10	0 - 6

All pressures are gauge pressures. Operating pressure values were determined with static operating pressure applied on one side of a closed valve. Sealing at the valve seat and atmospheric sealing is ensured for the given values.

Information on operating pressures applied on both sides and for high purity media on request.

Pressure rating: PN 10

Pressure/temperature correlation:

Valve body material		Temperature in °C (valve body)											
Materials	Code	-10	±0	5	10	20	25	30	40	50	60	70	80
PVC-U	1	-	-	-	10,0	10,0	10,0	8,0	6,0	3,5	1,5	-	-
ABS	4	10,0	10,0	10,0	10,0	10,0	10,0	8,0	6,0	4,0	2,0	-	-
PP	5	-	-	10,0	10,0	10,0	10,0	8,5	7,0	5,5	4,0	2,7	1,5
PP-H	71	-	-	10,0	10,0	10,0	10,0	8,5	7,0	5,5	4,0	2,7	1,5
PVDF	20	10,0	10,0	10,0	10,0	10,0	10,0	9,0	8,0	7,1	6,3	5,4	4,7
PVDF	75	10,0	10,0	10,0	10,0	10,0	10,0	9,0	8,0	7,1	6,3	5,4	4,7

Data for extended temperature ranges on request. Please note that the ambient temperature and media temperature generate a combined temperature at the valve body which must not exceed the above values.

Kv values:

MG	DN	Kv values
20	15	6.0
	20	10.0
	25	12.0
25	32	20.0
40	40	42.0
	50	46.0
50	65	70.0
80	80	120.0
100	100	189.0

MG = diaphragm size, Kv values in m³/h

Kv values determined acc.to DIN EN 60534 standard, inlet pressure 5 bar, Δp 1 bar, PVC-U valve body and soft elastomer diaphragm.

The Kv values for other product configurations (e.g. other diaphragm or body materials) may differ. In general, all diaphragms are subject to the influences of pressure, temperature, the process and their tightening torques. Therefore the Kv values may exceed the tolerance limits of the standard.

The Kv value curve (Kv value dependent on valve stroke) can vary depending on the diaphragm material and duration of use.

6.4 Product conformity

Pressure Equipment Directive: 2014/68/EU

Food: FDA*
Regulation (EC) No. 1935/2004
Regulation (EC) No. 10/2011*

EAC: TR CU 010/2011

Drinking water: NSF/ANSI*
* depending on version and/or operating parameters

6.5 Materials

Materials:

Diaphragm material	O-ring material
PTFE	FKM
NBR	EPDM
FKM	FKM
EPDM	EPDM

6.6 Mechanical data

Protection class: IP 65 acc. to EN 60529

Weight:

Actuator

MG	Actuator size	Weight
20	ED	0.30
20	EF	0.35
25	FD	0.40
40	HD	0.60
65	KD	1.00
80	MD	3.80
100	ND	5.10

MG = diaphragm size, weight in kg

Valve body

MG	DN	Spigot		Union end				Flange
		Connection type code						
		0, 30	20	7, 7R	33	3M, 3T	78	
20	15	0.12	0.10	0.17	0.24	0.26	0.27	0.67
	20	0.13	0.12	0.21	0.28	0.30	0.36	0.84
	25	0.16	0.14	0.26	0.33	0.38	0.37	1.28
25	32	0.22	0.18	0.40	0.70	0.73	0.63	1.89
40	40	0.50	0.40	0.73	0.83	0.93	1.13	2.36
	50	0.57	0.47	1.00	1.40	1.50	1.60	3.08
50	65	0.92	3.57	-	-	-	-	3.20
80	80	4.00	3.30	-	-	-	-	6.70
100	100	4.40	4.00	-	-	-	-	8.20

MG = diaphragm size

Weights in kg

Installation position: Optional

Flow direction: Optional

7 Dimensions

7.1 Actuator dimensions

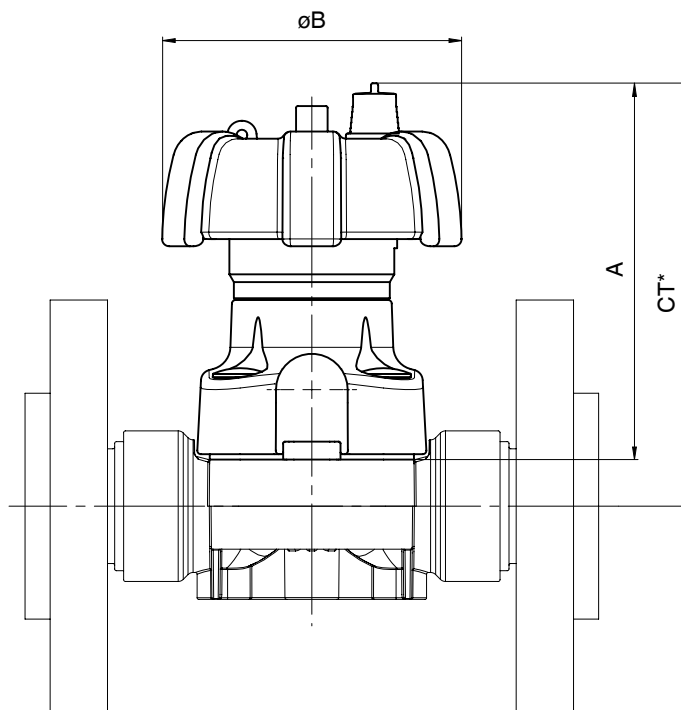
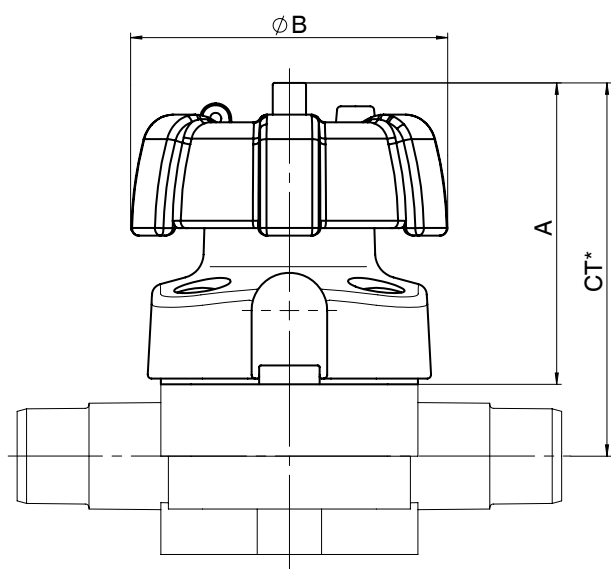

Actuator size EF
connection code 4, 39

MG	DN	Actuator size	ØB	A	
				Control function 0	Control function L
20	15 - 25	ED	90.0	75.0	83.0
20	15 - 25	EF	90.0	99.0	107.0
25	32	FD	90.0	79.0	87.0
40	40 - 50	HD	114.0	99.0	101.0
50	65	KD	140.0	119.0	122.0
80	80	MD	214.0	167.0	169.0
100	100	ND	214.0	216.0	211.0

* only for control function code L

* CT = A + H1 (see body dimensions)

Dimensions in mm

7.2 Body dimensions

7.2.1 Spigot DIN / inch (code 0, 30)

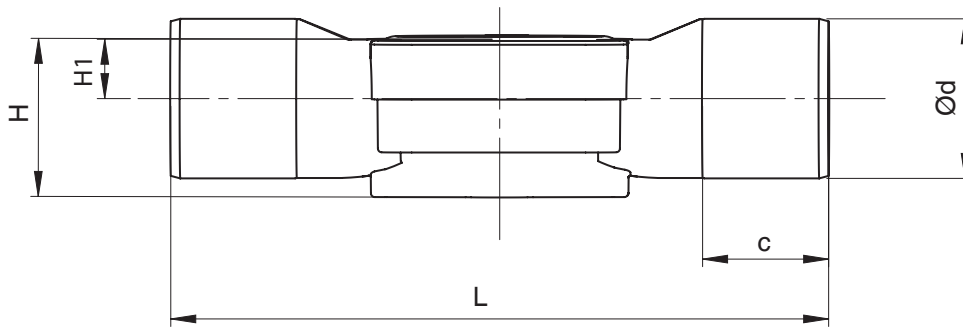

Connection type spigot DIN (code 0)¹⁾, body material PVC-U (code 1), PP (code 5), PVDF (code 20), inliner/outliner (code 71, 75)²⁾

MG	DN	NPS	c			ød	H			H1	L
			Material				Material				
			1	5, 20	71, 75		1	5, 20	71, 75		
20	15	1/2"	16.0	-	18.0	20.0	36.0	-	36.0	10.0	124.0
	20	3/4"	19.0	-	19.0	25.0	38.0	-	38.0	12.0	144.0
	25	1"	22.0	-	22.0	32.0	39.0	-	39.0	13.0	154.0
25	32	1 1/4"	32.0	-	32.0	40.0	41.0	-	41.0	15.0	174.0
40	40	1 1/2"	35.0	-	26.0	50.0	63.2	-	63.2	23.2	194.0
	50	2"	38.0	-	33.0	63.0	63.2	-	63.2	23.2	224.0
50	65	2 1/2"	46.0	46.0	-	75.0	78.8	78.8	-	38.8	284.0
80	80	3"	51.0	51.0	-	90.0	117.0	117.0	-	62.0	300.0
100	100	4"	61.0	61.0	-	110.0	140.0	140.0	-	75.0	340.0

Connection type spigot - inch (code 30)¹⁾, body material PVC-U (code 1), ABS (code 4)²⁾

MG	DN	NPS	c	ød	H	H1	L
20	15	1/2"	24.0	21.4	36.0	10.0	141.0
	20	3/4"	27.0	26.7	38.0	12.0	144.0
	25	1"	30.0	33.6	39.0	13.0	154.0
25	32	1 1/4"	33.0	42.2	41.0	15.0	174.0
40	40	1 1/2"	35.0	48.3	63.2	23.2	194.0
	50	2"	40.0	60.3	63.2	23.2	224.0
50	65	2 1/2"	46.0	73.0	78.8	38.8	284.0
80	80	3"	51.0	88.9	117.0	62.0	300.0
100	100	4"	61.0	114.3	140.0	75.0	340.0

Dimensions in mm

MG = diaphragm size

1) Connection type

Code 0: Spigot DIN

Code 30: Spigot - inch, for welding or solvent cementing, depending on the body material

2) Valve body material

Code 1: PVC-U, grey

Code 4: ABS

Code 5: PP, reinforced

Code 20: PVDF

Code 71: Inliner PP-H, grey, outliner PP, reinforced

Code 75: Inliner PVDF/outliner PP, reinforced

7.2.2 Spigot IR (code 20)

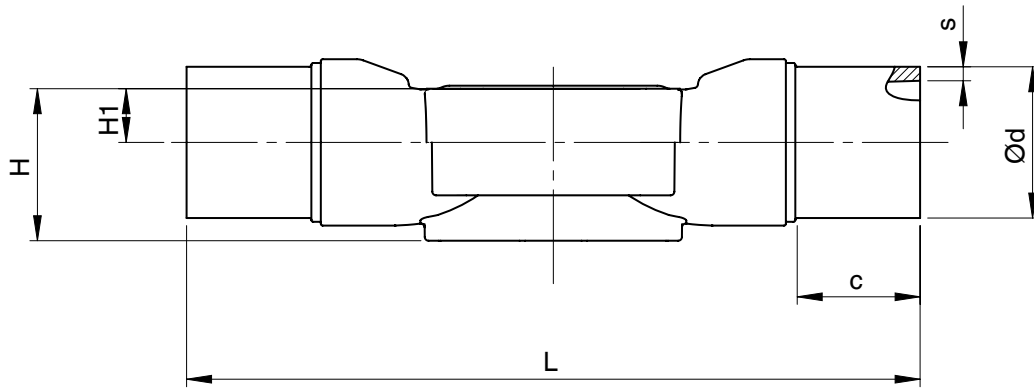
Connection type spigot IR (code 20)¹⁾, body material inliner/outliner (code 71, 75)²⁾

MG	DN	NPS	c	ød	H	H1	L	s	
								Material	
								71	75
20	15	1/2"	33.0	20.0	36.0	10.0	154.0	1.9	1.9
	20	3/4"	33.0	25.0	38.0	12.0	154.0	2.3	1.9
	25	1"	33.0	32.0	39.0	13.0	154.0	2.9	2.4
25	32	1¼"	33.0	40.0	41.0	15.0	194.0	3.7	2.4
40	40	1½"	33.0	50.0	63.2	23.2	194.0	4.6	3.0
	50	2"	33.0	63.0	63.2	23.2	224.0	5.8	3.0

Connection type spigot IR (code 20)¹⁾, body material PVDF (code 20)²⁾

MG	DN	NPS	c	ød	H	H1	L	s
50	65	2½"	43.0	75.0	78.8	38.8	284.0	3.6
80	80	3"	51.0	90.0	117.0	62.0	300.0	4.3
100	100	4"	59.0	110.0	140.0	75.0	340.0	5.3

Dimensions in mm

MG = diaphragm size

1) Connection type

Code 20: Spigot for IR butt welding

2) Valve body material

Code 20: PVDF

Code 71: Inliner PP-H, grey, outliner PP, reinforced

Code 75: Inliner PVDF/outliner PP, reinforced

7.2.3 Union end DIN (code 7)

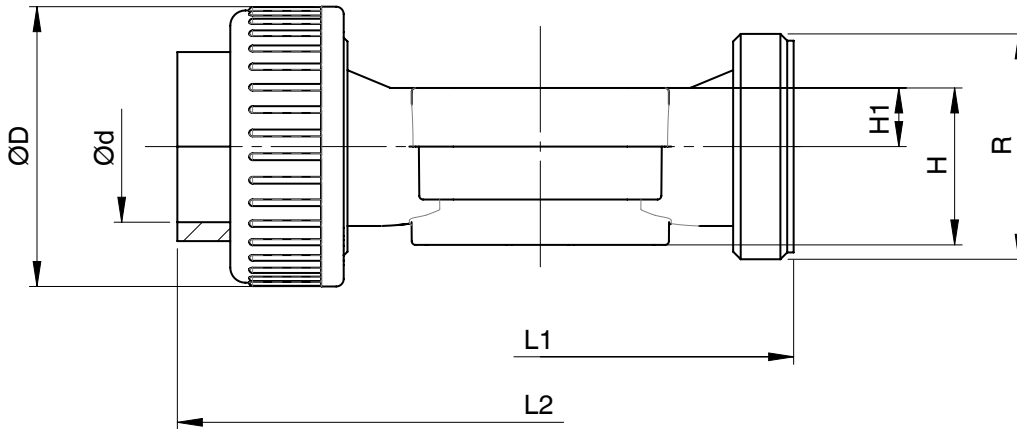

Connection type union end (code 7)¹⁾, body material PVC-U (code 1), ABS (code 4), inliner/outliner (code 71, 75)²⁾, diaphragm sizes 20 – 40

MG	DN	NPS	ød	øD	H	H1	L1	L2				R
								Material				
								1	4	71	75	
20	15	1/2"	20.0	43.0	36.0	10.0	108.0	146.0	150.0	143.0	146.0	G 1
	20	3/4"	25.0	53.0	38.0	12.0	108.0	152.0	156.0	146.0	150.0	G 1¼
	25	1"	32.0	60.0	39.0	13.0	116.0	166.0	170.0	158.0	162.0	G 1½
25	32	1¼"	40.0	74.0	41.0	15.0	134.0	192.0	196.0	181.0	184.0	G 2
40	40	1½"	50.0	83.0	63.2	23.2	154.0	222.0	222.0	207.0	210.0	G 2¼
	50	2"	63.0	103.0	63.2	23.2	184.0	266.0	266.0	245.0	248.0	G 2¾

Dimensions in mm

MG = diaphragm size

1) Connection type

Code 7: Union end with insert (socket) – DIN

2) Valve body material

Code 1: PVC-U, grey

Code 4: ABS

Code 71: Inliner PP-H, grey, outliner PP, reinforced

Code 75: Inliner PVDF/outliner PP, reinforced

7.2.4 Union end inch (code 33, 3M, 3T)

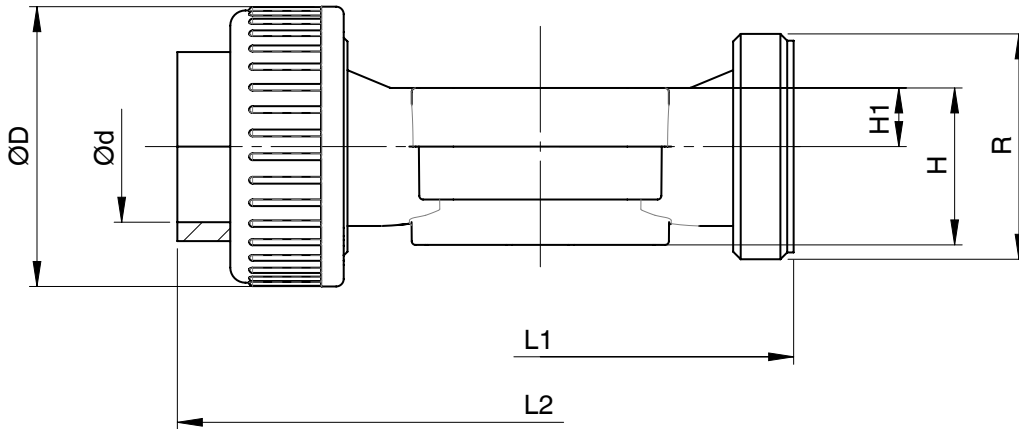

Connection type union end inch (code 33, 3M, 3T)¹⁾, body material PVC-U (code 1)²⁾, diaphragm sizes 20 - 40

MG	DN	NPS	ød			øD		H	H1	L1	L2			R	
			Connection type								Connection type				
			33	3M	3T	33, 3M	3T				33	3M	3T	33, 3M	3T
20	15	1/2"	21.4	21.4	22.0	43.0	53.0 *	36.0	10.0	108.0	146.0	158.0	152.0	G 1	G 1¼ *
	20	3/4"	26.8	26.7	26.0	53.0	53.0	38.0	12.0	108.0	152.0	164.0	152.0	G 1¼	G 1¼
	25	1"	33.6	33.5	32.0	60.0	60.0	39.0	13.0	116.0	166.0	180.0	166.0	G 1½	G 1½
25	32	1¼"	42.3	42.2	38.0	74.0	74.0	41.0	15.0	134.0	192.0	204.0	192.0	G 2	G 2
40	40	1½"	48.3	48.3	48.0	83.0	83.0	63.2	23.2	154.0	222.0	230.0	222.0	G 2¼	G 2¼
	50	2"	60.4	60.4	60.0	103.0	103.0	63.2	23.2	184.0	264.0	266.0	266.0	G 2¾	G 2¾

Connection type BS (code 33)¹⁾, body material ABS (code 4)²⁾

MG	DN	NPS	ød	øD	H	H1	L1	L2	R
20	15	1/2"	21.4	43.0	36.0	10.0	108.0	150.0	G 1
	20	3/4"	26.8	53.0	38.0	12.0	108.0	156.0	G 1¼
	25	1"	33.6	60.0	39.0	13.0	116.0	170.0	G 1½
25	32	1¼"	42.3	74.0	41.0	15.0	134.0	198.0	G 2
40	40	1½"	48.3	83.0	63.2	23.2	154.0	220.0	G 2¼
	50	2"	60.4	103.0	63.2	23.2	184.0	264.0	G 2¾

Dimensions in mm

MG = diaphragm size

* Insert requires valve body DN 20

1) Connection type

- Code 33: Union end with inch insert – BS (socket)
- Code 3M: Union end with inch insert – ASTM (socket)
- Code 3T: Union end with insert – JIS (socket)

2) Valve body material

- Code 1: PVC-U, grey
- Code 4: ABS

7.2.5 Union end DIN (code 78)

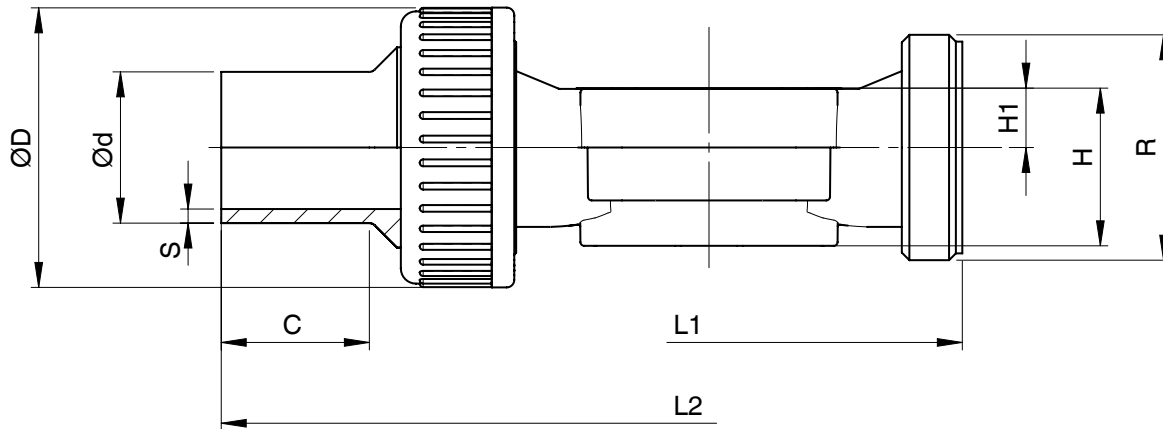

Connection type union end DIN, IR butt welding (code 78)¹⁾, body materials inliner/outliner (code 71, 75)²⁾

MG	DN	NPS	c	ød	øD	H	H1	L1	L2	R	s	
											Material	
											71	75
20	15	1/2"	36.0	20.0	43.0	36.0	10.0	108.0	214.0	G 1	1.9	1.9
	20	3/4"	37.0	25.0	53.0	38.0	12.0	108.0	220.0	G 1¼	2.3	1.9
	25	1"	39.0	32.0	60.0	39.0	13.0	116.0	234.0	G 1½	2.9	2.4
25	32	1¼"	39.0	40.0	74.0	41.0	15.0	134.0	258.0	G 2	3.7	2.4
40	40	1½"	43.0	50.0	83.0	63.2	23.2	154.0	284.0	G 2¼	4.6	3.0
	50	2"	43.0	63.0	103.0	63.2	23.2	184.0	320.0	G 2¾	5.8	3.0

Dimensions in mm

MG = diaphragm size

1) **Connection type**

Code 78: Union end with insert (for IR butt welding) – DIN

2) **Valve body material**

Code 71: Inliner PP-H, grey, outliner PP, reinforced

Code 75: Inliner PVDF/outliner PP, reinforced

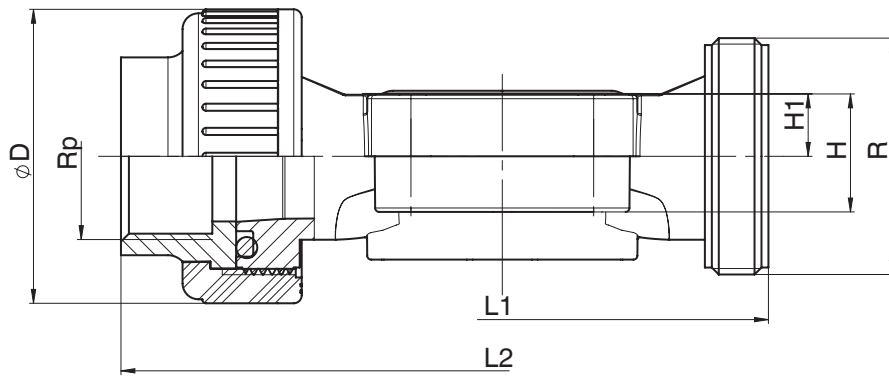
7.2.6 Union end Rp (code 7R)**Connection type union end Rp (code 7R) ¹⁾, body material PVC-U (code 1) ²⁾**

MG	DN	NPS	øD	H	H1	L1	L2	R	Rp
20	15	1/2"	43.0	36.0	10.0	108.0	146.0	G 1	1/2
	20	3/4"	53.0	38.0	12.0	108.0	152.0	G 1¼	3/4
	25	1"	60.0	39.0	13.0	116.0	166.0	G 1½	1
25	32	1¼"	74.0	41.0	15.0	134.0	192.0	G 2	1¼
40	40	1½"	83.0	63.2	23.2	154.0	222.0	G 2¼	1½
	50	2"	103.0	63.2	23.2	184.0	266.0	G 2¾	2

Dimensions in mm

MG = diaphragm size

1) Connection type

Code 7R: Union end with insert (Rp threaded socket) – DIN

2) Valve body material

Code 1: PVC-U, grey

7.2.7 Flange EN (code 4)

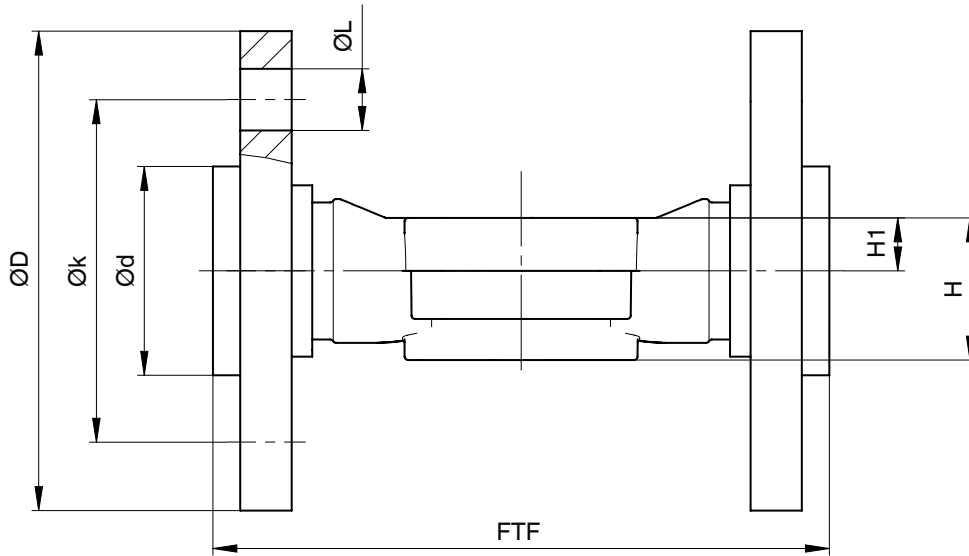

Connection type flange EN (code 4)¹⁾, body material PVC-U (code 1)²⁾

MG	DN	NPS	ød	øD	FTF	H	H1	øk	øL	n
20	15	1/2"	34.0	95.0	130.0	36.0	10.0	65.0	14.0	4
	20	3/4"	41.0	105.0	150.0	38.0	12.0	75.0	14.0	4
	25	1"	50.0	115.0	160.0	39.0	13.0	85.0	14.0	4
25	32	1¼"	61.0	140.0	180.0	41.0	15.0	100.0	18.0	4
40	40	1½"	73.0	150.0	200.0	63.2	23.2	110.0	18.0	4
	50	2"	90.0	165.0	230.0	63.2	23.2	125.0	18.0	4
50	65	2½"	106.0	185.0	290.0	78.8	38.8	145.0	18.0	4
80	80	3"	125.0	200.0	310.0	117.0	62.0	160.0	18.0	8
100	100	4"	150.0	220.0	350.0	140.0	75.0	180.0	18.0	8

Connection type flange EN (code 4)¹⁾, body materials PP (code 5), PVDF (code 20)²⁾

MG	DN	NPS	ød		øD	FTF	H	H1	øk	øL	n
			Material								
			5	20							
50	65	2½"	122.0	120.0	185.0	290.0	78.8	38.8	145.0	18.0	4
80	80	3"	138.0	125.0	200.0	310.0	117.0	62.0	160.0	18.0	8
100	100	4"	158.0	150.0	220.0	350.0	140.0	75.0	180.0	18.0	8

Dimensions in mm

MG = diaphragm size

n = number of bolts

1) **Connection type**

Code 4: Flange EN 1092, PN 10, form B, face-to-face dimension FTF EN 558 series 1, ISO 5752, basic series 1

2) **Valve body material**

Code 1: PVC-U, grey

Code 5: PP, reinforced

Code 20: PVDF

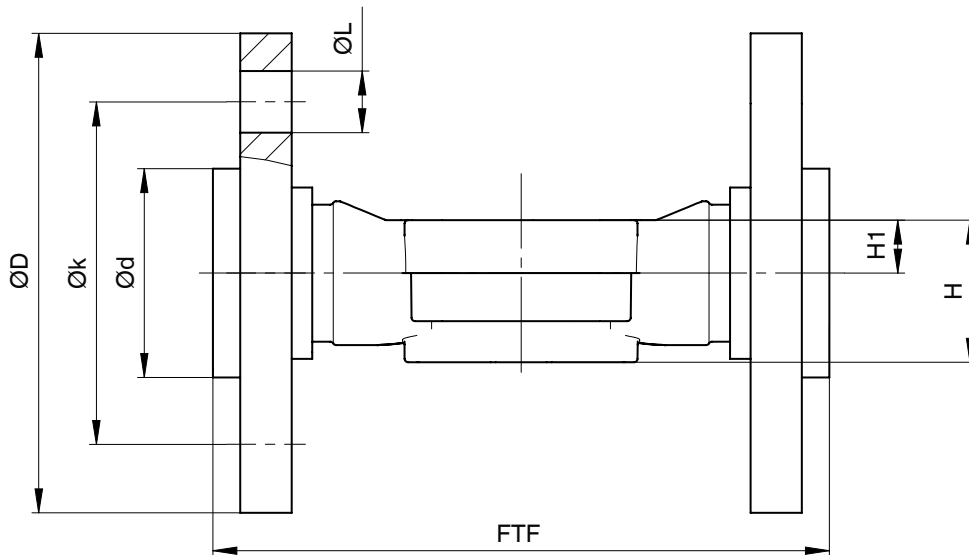

Connection type flange EN (code 4)¹⁾, body material inliner/outliner (code 71, 75)²⁾

MG	DN	NPS	ød	øD	FTF	H	H1	øk	øL	n
20	15	1/2"	45.0	95.0	130.0	36.0	10.0	65.0	14.0	4
	20	3/4"	58.0	105.0	150.0	38.0	12.0	75.0	14.0	4
	25	1"	68.0	115.0	160.0	39.0	13.0	85.0	14.0	4
25	32	1¼"	78.0	140.0	180.0	41.0	15.0	100.0	18.0	4
40	40	1½"	88.0	150.0	200.0	63.2	23.2	110.0	18.0	4
	50	2"	102.0	165.0	230.0	63.2	23.2	125.0	18.0	4

Dimensions in mm

MG = diaphragm size

n = number of bolts

1) **Connection type**

Code 4: Flange EN 1092, PN 10, form B, face-to-face dimension FTF EN 558 series 1, ISO 5752, basic series 1

2) **Valve body material**

Code 71: Inliner PP-H, grey, outliner PP, reinforced

Code 75: Inliner PVDF/outliner PP, reinforced

7.2.8 Flange ANSI Class (code 39)

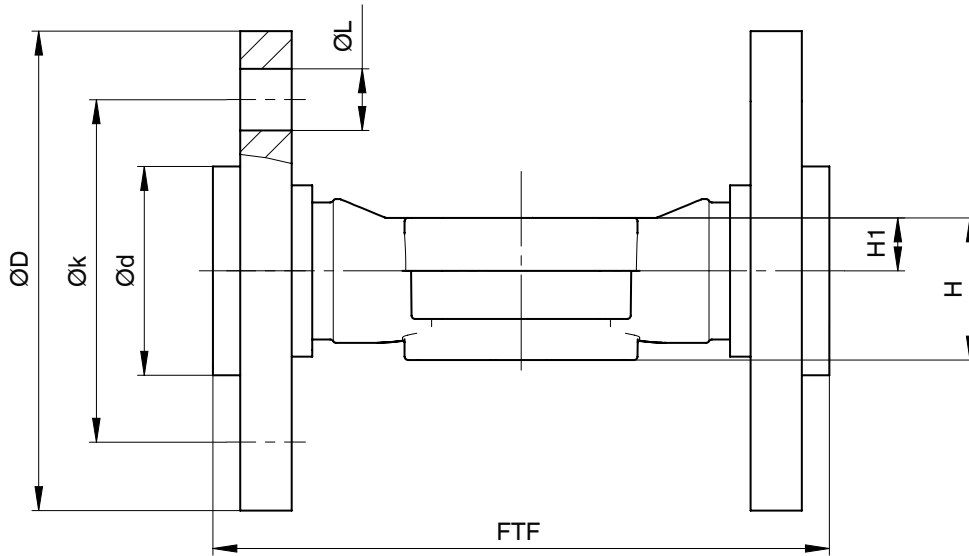

Connection type flange ANSI (code 39)¹⁾, body material PVC-U (code 1)²⁾

MG	DN	NPS	ød	øD	FTF	H	H1	øk	øL	n
20	15	1/2"	34.0	95.0	130.0	36.0	10.0	60.0	16.0	4
	20	3/4"	41.0	105.0	150.0	38.0	12.0	70.0	16.0	4
	25	1"	50.0	115.0	160.0	39.0	13.0	79.0	16.0	4
25	32	1¼"	61.0	140.0	180.0	41.0	15.0	89.0	16.0	4
40	40	1½"	73.0	150.0	200.0	63.2	23.2	98.0	16.0	4
	50	2"	90.0	165.0	230.0	63.2	23.2	121.0	19.0	4
50	65	2½"	106.0	185.0	290.0	78.8	38.8	140.0	19.0	4
80	80	3"	125.0	200.0	310.0	117.0	62.0	152.0	19.0	4
100	100	4"	150.0	229.0	350.0	140.0	75.0	190.0	19.0	8

Connection type flange ANSI (code 39)¹⁾, body material PP (code 5), PVDF (code 20)²⁾

MG	DN	NPS	ød		øD	FTF	H	H1	øk	øL	n
			Material								
			5	20							
50	65	2½"	122.0	120.0	185.0	290.0	78.8	38.8	140.0	19.0	4
80	80	3"	133.0	125.0	200.0	310.0	117.0	62.0	152.0	19.0	4
100	100	4"	158.0	150.0	229.0	350.0	140.0	75.0	190.0	19.0	8

Dimensions in mm

MG = diaphragm size

n = number of bolts

1) **Connection type**

Code 39: Flange ANSI Class 125/150 RF, face-to-face dimension FTF EN 558 series 1, ISO 5752, basic series 1, length only for body configuration D

2) **Valve body material**

Code 1: PVC-U, grey

Code 5: PP, reinforced

Code 20: PVDF

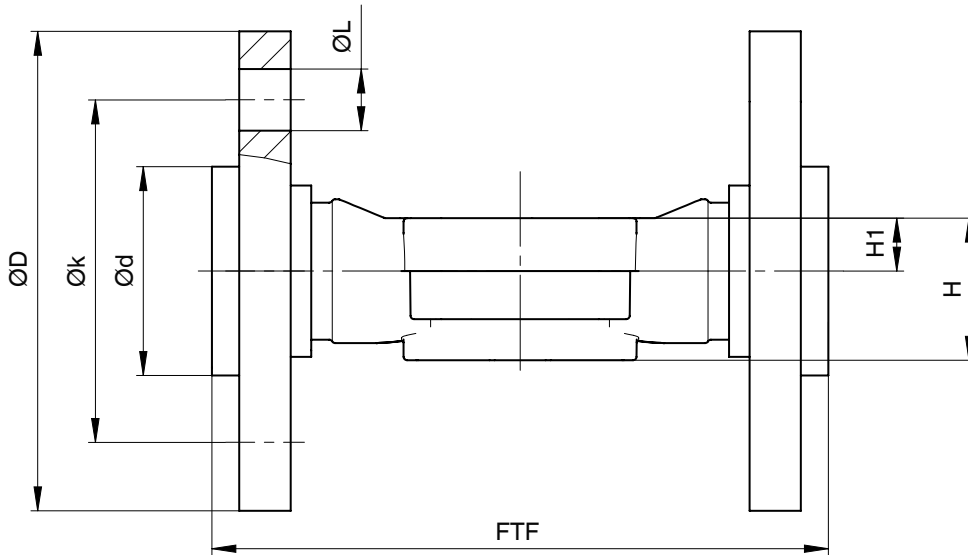

Connection type flange ANSI (code 39)¹⁾, inliner/outliner body material (code 71, 75)²⁾

MG	DN	NPS	ød	øD	FTF	H	H1	øk	øL	n
20	15	1/2"	45.0	95.0	130.0	36.0	10.0	60.0	16.0	4
	20	3/4"	54.0	105.0	150.0	38.0	12.0	70.0	16.0	4
	25	1"	63.0	115.0	160.0	39.0	13.0	79.0	16.0	4
25	32	1¼"	73.0	140.0	180.0	41.0	15.0	89.0	16.0	4
40	40	1½"	82.0	150.0	200.0	63.2	23.2	98.0	16.0	4
	50	2"	102.0	165.0	230.0	63.2	23.2	121.0	19.0	4

Dimensions in mm

MG = diaphragm size

n = number of bolts

1) **Connection type**

Code 39: Flange ANSI Class 125/150 RF, face-to-face dimension FTF EN 558 series 1, ISO 5752, basic series 1, length only for body configuration D

2) **Valve body material**

Code 71: Inliner PP-H, grey, outliner PP, reinforced

Code 75: Inliner PVDF/outliner PP, reinforced

7.3 Valve body mounting

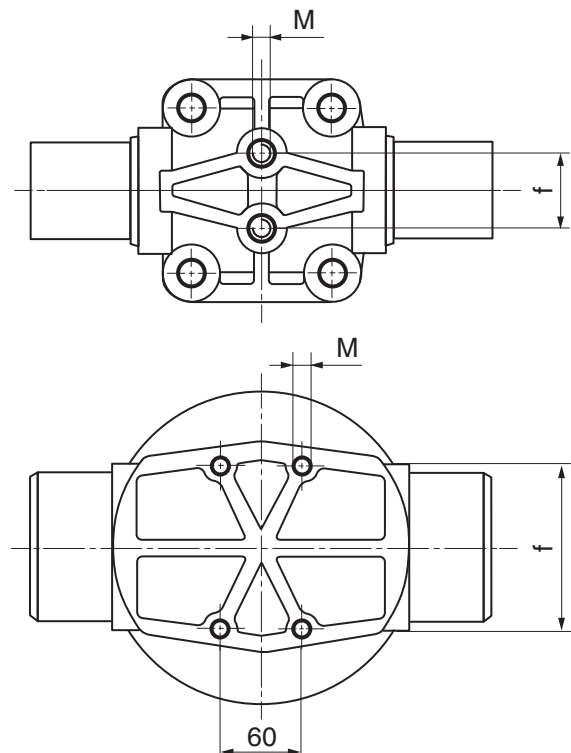

MG	DN	M Connection code 0, 4, 7, 7R, 20, 33, 39, 3M, 3T, 78	M Connection code 30	f
20	15 - 25	M6	M6 *	25.0
25	32	M6	M6 *	25.0
40	40 - 50	M8	M8 *	44.5
50	65	M8	M8 *	44.5
80	80	M12	1/2" **	100.0
100	100	M10	3/4" **	120.0

Dimensions in mm, MG = diaphragm size

* Inch thread on request

** Metric thread on request

8 Delivery

- Check that all parts are present and check for any damage immediately upon receipt.

The product's performance is tested at the factory. The scope of delivery is apparent from the dispatch documents and the design from the order number.

9 Transport



1. Only transport the product by suitable means. Do not drop. Handle carefully.
2. After the installation dispose of transport packaging material according to relevant local or national disposal regulations / environmental protection laws.

10 Storage

1. Store the product free from dust and moisture in its original packaging.
2. Avoid UV rays and direct sunlight.
3. Do not exceed the maximum storage temperature (see chapter "Technical data").
4. Do not store solvents, chemicals, acids, fuels or similar fluids in the same room as GEMÜ products and their spare parts.

11 Installation in piping

11.1 Preparing for installation

⚠ WARNING	
The equipment is subject to pressure!	
<ul style="list-style-type: none"> ▶ Risk of severe injury or death ● Depressurize the plant. ● Completely drain the plant. 	
⚠ WARNING	
	Corrosive chemicals!
	<ul style="list-style-type: none"> ▶ Risk of caustic burns ● Wear appropriate protective gear. ● Completely drain the plant.
⚠ CAUTION	
	Hot plant components!
	<ul style="list-style-type: none"> ▶ Risk of burns ● Only work on plant that has cooled down.
⚠ CAUTION	
Exceeding the maximum permissible pressure!	
<ul style="list-style-type: none"> ▶ Damage to the product ● Provide precautionary measures against exceeding the maximum permitted pressures caused by pressure surges (water hammer). 	
⚠ CAUTION	
Use as step.	
<ul style="list-style-type: none"> ▶ Damage to the product ▶ Risk of slipping-off ● Choose the installation location so that the product cannot be used as a foothold. ● Do not use the product as a step or a foothold. 	
NOTICE	
Suitability of the product!	
<ul style="list-style-type: none"> ▶ The product must be appropriate for the piping system operating conditions (medium, medium concentration, temperature and pressure) and the prevailing ambient conditions. 	

NOTICE**Tools**

- ▶ The tools required for installation and assembly are not included in the scope of delivery.
- Use appropriate, functional and safe tools.

1. Ensure the product is suitable for the relevant application.
2. Check the technical data of the product and the materials.
3. Keep appropriate tools ready.
4. Wear appropriate protective gear, as specified in the plant operator's guidelines.
5. Observe appropriate regulations for connections.
6. Have installation work carried out by trained personnel.
7. Shut off plant or plant component.
8. Secure plant or plant component against recommissioning.
9. Depressurize the plant or plant component.
10. Completely drain the plant (or plant component) and let it cool down until the temperature is below the media vaporization temperature and cannot cause scalding.
11. Correctly decontaminate, rinse and ventilate the plant or plant component.
12. Lay piping so that the product is protected against transverse and bending forces, and also from vibrations and tension.
13. Only install the product between matching aligned pipes (see chapters below).
14. Please note the flow direction (see chapter "Flow direction").
15. Please note the installation position (see chapter "Installation position").

11.2 Installation with butt weld spigots

Fig. 1: Butt weld spigots

1. Carry out preparations for installation (see chapter "Preparing for installation").
2. Adhere to good welding practices!
3. Disassemble the actuator with the diaphragm before welding in the valve body (see "Removing the actuator" chapter).
4. Weld the body of the product in the piping.
5. Allow butt weld spigots to cool down.
6. Reassemble the valve body and the actuator with diaphragm (see "Mounting the actuator" chapter).
7. Re-attach or reactivate all safety and protective devices.
8. Flush the system.

11.3 Installation with union ends

Fig. 2: Union end with insert

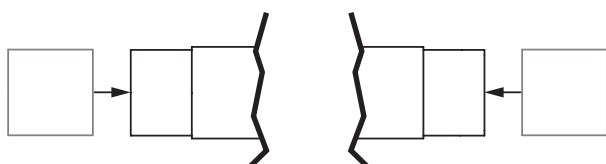
NOTICE

- ▶ The solvent cement is not included in the scope of delivery.
- Only use suitable solvent cement!

1. Keep solvent cement ready.
2. Carry out preparations for installation (see chapter "Preparing for installation").
3. Adhere to good welding practices!
4. Screw the threaded connections into the piping in accordance with valid standards.
5. Unscrew the union nut from the GEMÜ R677 body.
6. Reinsert the O-ring if necessary.
7. Push the union nut over the piping.
8. Connect the insert with the piping by solvent cementing/welding.
9. Screw the union nut back onto the GEMÜ R677 body.
10. Connect the GEMÜ R677 body to the piping on the other side in a like manner.
11. Re-attach or reactivate all safety and protective devices.

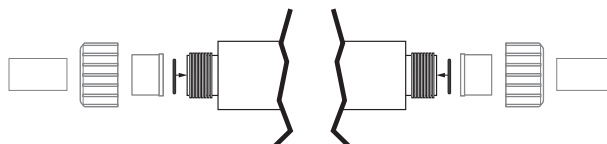
11.4 Installation with flanged connection

Fig. 3: Flanged connection

NOTICE**Sealing material**

- ▶ The sealing material is not included in the scope of delivery.
- Only use appropriate sealing material.

NOTICE

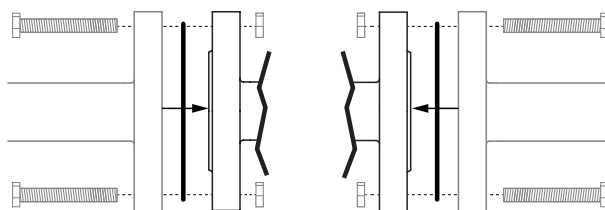
Connector elements

- ▶ The connector elements are not included in the scope of delivery.
- Only use connector elements made of approved materials.
- Observe permissible tightening torque of the bolts.

1. Keep sealing material ready.
2. Carry out preparations for installation (see chapter "Preparing for installation").
3. Ensure clean, undamaged sealing surfaces on the connection flanges.
4. Align flanges carefully before installing them.
5. Clamp the product centrally between the piping with flanges.
6. Centre the gaskets.
7. Connect the valve flange and the piping flange using appropriate sealing materials and matching bolting.
8. Use all flange holes.
9. Tighten the bolts diagonally.

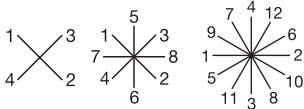

10. Re-attach or reactivate all safety and protective devices.

11.5 Installation with solvent cement spigots

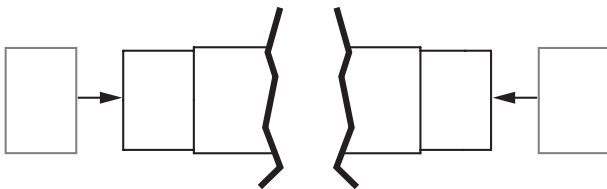

Fig. 4: Solvent cement spigot

NOTICE

- ▶ The solvent cement is not included in the scope of delivery.
- Only use suitable solvent cement!

1. Carry out preparations for installation (see chapter "Preparations for installation").
2. Apply solvent cement on the outside of the valve body spigots and on the inside of the piping as specified by the solvent cement manufacturer.
3. Connect the body of the product with the piping.
4. Reactivate all safety and protective devices.

11.6 After the installation

NOTICE

Diaphragms set in the course of time.

- ▶ Leakage
- After disassembly/assembly of the product, check that the bolts and nuts on the body are tight and retighten if required.
- Retighten the bolts and nuts at the very latest after the first sterilization process.
- Re-attach or reactivate all safety and protective devices.

12 Commissioning

⚠ WARNING



Corrosive chemicals!

- ▶ Risk of caustic burns
- Wear appropriate protective gear.
- Completely drain the plant.

⚠ CAUTION

Leakage!

- ▶ Emission of dangerous materials
- Provide precautionary measures against exceeding the maximum permitted pressures caused by pressure surges (water hammer).

NOTICE

Prior to cleaning or commissioning the plant:

- Check the tightness and the function of the valve (close and reopen the valve).
- If the plant is new and after repairs rinse the piping system with a fully opened valve (to remove any harmful foreign matter).

⚠ CAUTION

Cleaning agent

- ▶ Damage to the GEMÜ product.
- The plant operator is responsible for selecting the cleaning material and performing the procedure.

NOTICE

Diaphragms set in the course of time.

- ▶ Leakage
- After disassembly/assembly of the product, check that the bolts and nuts on the body are tight and retighten if required.
- Retighten the bolts and nuts at the very latest after the first sterilization process.

13 Operation

⚠ CAUTION



Handwheel can become hot during operation!

- ▶ Risk of burns
- Ensure protective gloves are worn when operating handwheel.

Optical position indicator



Valve open

Valve closed

Handwheel locknut GEMÜ 677 (optional)



Lock the handwheel:

Insert the key in the lock (arrow), press down and lock with an anticlockwise rotation. The key can be removed.

Unlock the handwheel:

Insert the key in the lock (arrow) and unlock with a clockwise rotation. The key cannot be removed.

14 Troubleshooting

Error	Possible cause	Troubleshooting
The product does not open or does not open fully	Shut-off diaphragm incorrectly mounted	Remove the actuator, check the diaphragm mounting, replace the shut-off diaphragm if necessary
	Actuator defective	Replace the actuator
The product is leaking downstream (does not close or does not close fully)	Operating pressure too high	Operate the product with operating pressure specified in datasheet
	Foreign matter between shut-off diaphragm and valve body	Remove the actuator, remove foreign matter, check diaphragm and valve body for potential damage, replace damaged parts if necessary
	Shut-off diaphragm faulty	Check shut-off diaphragm for potential damage, replace the shut off diaphragm if necessary
	Valve body leaking or damaged	Check valve body for potential damage, replace valve body if necessary
The product is leaking between actuator and valve body	Shut-off diaphragm incorrectly mounted	Remove the actuator, check the diaphragm mounting, replace the shut-off diaphragm if necessary
	Bolting between valve body and actuator loose	Tighten bolting between valve body and actuator
	Shut-off diaphragm faulty	Check shut-off diaphragm for potential damage, replace the shut-off diaphragm if necessary
	Actuator/valve body damaged	Replace actuator/valve body
Valve body connection to piping leaking	Incorrect installation	Check installation of valve body in piping
	Threaded connections / unions loose	Tighten threaded connections / unions
	Sealing material faulty	Replace sealing material
Valve body of the GEMÜ product is leaking	Valve body of the GEMÜ product is faulty or corroded	Check valve body of the GEMÜ product for potential damage, replace valve body if necessary
Handwheel cannot be turned	Actuator defective	Replace the actuator

15 Inspection and maintenance

15.1 Removing the actuator

1. Move the actuator **A** to the open position.
2. Loosen the fastening elements between actuator **A** and valve body **1** diagonally and remove them.
3. Lift actuator **A** off valve body **1**.
4. Move the actuator **A** to the closed position.
5. Clean all parts of contamination (do not damage parts during cleaning).
6. Check parts for potential damage, replace if necessary (only use genuine parts from GEMÜ).

15.2 Removing the diaphragm

1. Remove actuator **A** (see chapter "Removing the actuator").
2. Unscrew the diaphragm.
 - ⇒ Please note: Depending on the version, the compressor may fall out.
3. Clean all parts of contamination (do not damage parts during cleaning).
4. Check parts for potential damage, replace if necessary (only use genuine parts from GEMÜ).

15.3 Mounting the diaphragm

NOTICE

- ▶ Fit the diaphragms suitable for the product (suitable for medium, medium concentration, temperature and pressure). The diaphragm is a wearing part. Check the technical condition and function of the product before commissioning and during the whole term of use. Carry out checks regularly and determine the check intervals in accordance with the conditions of use and/or the regulatory codes and provisions applicable for this application.

NOTICE

- ▶ If the diaphragm is not screwed into the adapter far enough, the closing force is transmitted directly onto the diaphragm pin and not via the compressor. This will cause damage and early failure of the diaphragm and leakage of the product. If the diaphragm is screwed in too far, perfect sealing at the valve seat will not be achieved. The function of the product is no longer ensured.

NOTICE

- ▶ Incorrectly mounted diaphragms cause the product leakage and emission of medium. In this case, remove the diaphragms, check the complete valve and diaphragms and reassemble again proceeding as described above.

NOTICE

Diaphragm sizes 8 and 100:

- ▶ The compressor is fixed to the spindle.



Compressor and actuator flange seen from below.

15.3.1 Mounting a concave diaphragm

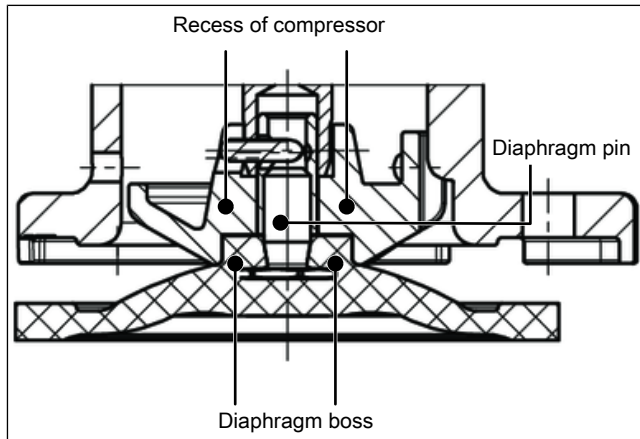

1. Move the actuator **A** to the closed position.
2. Check if the compressor is fitted in the guides.
3. Manually screw new diaphragm tightly into the compressor.
4. Check if the diaphragm boss fits closely in the recess of the compressor.
5. If it is difficult to screw it in, check the thread and replace damaged parts.
6. When definitive resistance is felt, turn back the diaphragm until its bolt holes are in correct alignment with the bolt holes of the actuator.
7. Align the weir of compressor and diaphragm in parallel.

15.4 Mounting the actuator

NOTICE

Diaphragms set in the course of time.

- ▶ Leakage
- After disassembly/assembly of the product, check that the bolts and nuts on the body are tight and retighten if required.
- Retighten the bolts and nuts at the very latest after the first sterilization process.

1. Move the actuator **A** to the open position.
2. Position actuator **A** with the mounted diaphragm on the valve body **1**.
3. Screw in bolts, washers and nuts hand tight.
 - ⇒ Fastening elements may vary depending on the diaphragm size and/or valve body version.
4. Move the actuator **A** to the closed position.
5. Open actuator **A** approx. 50%.
6. Fully tighten the bolts with nuts diagonally.
7. Ensure even compression of the diaphragm (approx. 10 to 15%).
 - ⇒ Even compression is detected by an even bulge to the outside.
 - Please note:** For a code 5M diaphragm (convex diaphragm), the PTFE diaphragm face and the EPDM backing diaphragm must be positioned level with and parallel to the valve body.
8. With the valve fully assembled, check the function and tightness.

15.5 Sectional drawing and spare parts

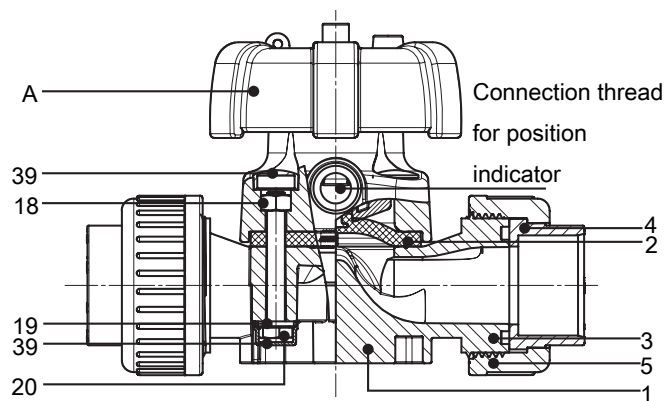

Item	Name	Order designation
1	Valve body	B690
3	O-ring	
4	Insert	
5	Union nut	
2	Diaphragm	R690...M...
18	Bolt	R677...S30
19	Washer	
20	Nut	
39	Protective cap	
A	Actuator	A677

16 Disposal

1. Pay attention to adhered residual material and gas diffusion from penetrated media.
2. Dispose of all parts in accordance with the disposal regulations/environmental protection laws.

17 Returns

Legal regulations for the protection of the environment and personnel require that the completed and signed return delivery note is included with the dispatch documents. Returned goods can be processed only when this note is completed. If no return delivery note is included with the product, GEMÜ cannot process credits or repair work but will dispose of the goods at the operator's expense.

1. Clean the product.
2. Request a return delivery note from GEMÜ.
3. Complete the return delivery note.
4. Send the product with a completed return delivery note to GEMÜ.

18 EU Declaration of Conformity in accordance with 2014/68/EU (Pressure Equipment Directive)



EU Declaration of Conformity

in accordance with 2014/68/EU (Pressure Equipment Directive)

We, the company GEMÜ Gebr. Müller Apparatebau GmbH & Co. KG
Fritz-Müller-Strasse 6-8
74653 Ingelfingen-Criesbach, Germany

hereby declare under our sole responsibility that the below-mentioned product complies with the regulations of the above-mentioned Directive.

Product: GEMÜ R677
Product name: Manually operated diaphragm valve
Notified body: TÜV Rheinland Industrie Service GmbH
Am Grauen Stein 1
51105 Cologne, Germany

ID number of the notified body: 0035
No. of the QA certificate: 01 202 926/Q-02 0036

Applied conformity assessment procedure(s): Module H

The following harmonized standards (or parts thereof) have been applied: EN ISO 16138:2006/A1:2019

Information for products with a nominal size \leq DN 25:

The products are developed and produced according to GEMÜ's in-house process instructions and standards of quality which comply with the requirements of ISO 9001 and ISO 14001. According to Article 4, Paragraph 3 of the Pressure Equipment Directive 2014/68/EU, these products must not be identified by a CE-marking.

Other applied technical standards / Remarks:

- AD 2000

M. Barghoorn
Head of Global Technics
Ingelfingen, 21/09/2023



GEMÜ Gebr. Müller Apparatebau GmbH & Co. KG
Fritz-Müller-Straße 6-8, 74653 Ingelfingen-Criesbach, Germany
Phone +49 (0) 7940 1230 · info@gemue.de
www.gemu-group.com

Subject to alteration

03.2024 | 88836656