

Globe Control Valve, Metal

Construction

The GEMÜ 534 2/2-way globe control valve is designed for demanding flow control applications. It can be paired with the GEMÜ 1434 μ Pos, GEMÜ 1435 ePos positioners or the GEMÜ 1436 cPos positioner and process controller dependent on the control requirements (for features see page 8). The positioners are specially designed for GEMÜ valves and achieve optimum results when used as a system. The valve spindle is sealed by a self-adjusting gland packing providing low maintenance and reliable sealing even after a long service life with high cycle duties. A wiper ring protects the gland packing against contamination and damage.

Features

- Linear or modified equal-percentage control characteristics
- Kv values from approx. 0.16 - 140 m³/h, depending on nominal size, valve seat and regulating cone design
- PID control system can be implemented with GEMÜ 1436
- Suitable for inert, corrosive*, liquid and gaseous media and steam
- Flanged bodies in SG iron GGG 40.3 and stainless steel 1.4408 to EN 1092 and ANSI 125/150
- Valve body DN 15 - 100, pressure rating to PN 40
- Max. operating temperature 180°C

Advantages

- Simple and fast commissioning
- Valve and positioner are optimally adapted to each other.
(For positioner details please refer to the relevant data sheets)
- Standard gland packing suitable for vacuum up to 20 mbar (abs.)

*see information on working medium on page 2



**GEMÜ 534
+ 1434 μ Pos**



**GEMÜ 534
+ 1435 ePos**



**GEMÜ 534
+ 1436 cPos**

Sectional drawing

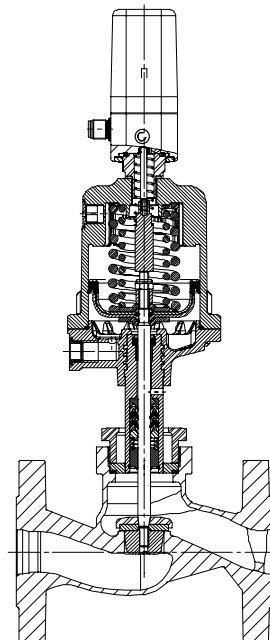

Technical data

Working medium

Corrosive, inert, gaseous and liquid media and steam which have no negative impact on the physical and chemical properties of the body and seal material.

Max. perm. pressure of working medium see table

Media temperature -10° to 180 °C

Max. permissible viscosity 600 mm²/s (cSt)

Control medium

Inert gases, max. 60 °C

Filling volume	Actuator size 0:	0.050 dm ³
	Actuator size 1:	0.125 dm ³
	Actuator size 2:	0.625 dm ³

Ambient conditions

Max. ambient temperature 60 °C

Maximum permissible seat leakage class

Seat seal	Standard	Test procedure	Leakage rate	Test medium
PTFE	DIN EN 60534-4	1	VI	air
Metal	DIN EN 60534-4	1	IV	air

Pressure / temperature correlation for globe valve bodies

Connection code	Material code	Max. allowable operating pressures in bar at temperature °C*					
		RT	100	150	200	250	300
8	37	16.0	16.0	14.5	13.4	12.7	11.8
10	37	25.0	25.0	22.7	21.0	19.8	18.5
11	37	40.0	40.0	36.3	33.7	31.8	29.7
39	37	19.0	16.0	14.8	13.6	12.0	10.2
8	90	16.0	16.0	15.5	14.7	13.9	11.2
39	90	17.0	16.0	14.8	13.9	12.1	10.2

* The valves can be used down to -10°C RT = Room Temperature All pressures are gauge pressures.
Pressure/temperature correlation for connection code 48: DN 15 - 40 see connection code 10, DN 50 see connection code 8.

Example Kv value diagram

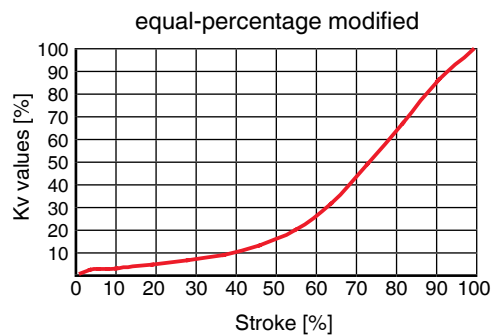
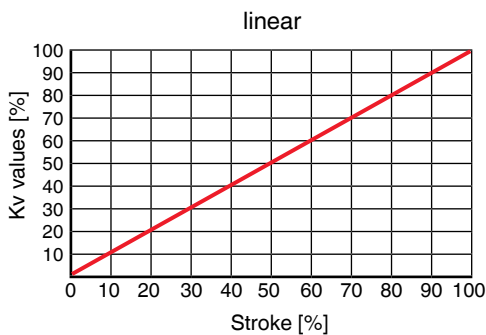

The adjacent diagram shows the approximative curve of the Kv value characteristic. The characteristic may deviate dependent on valve body, nominal size, regulating cone and valve stroke.

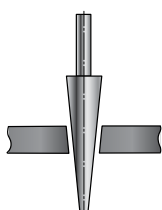

Regulating needle

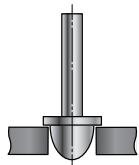

Regulating cone

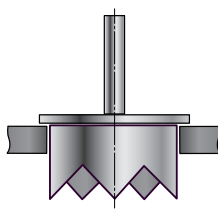

Regulating cage

Note:

Regulating needle: RAxxx - RCxxx (reduced valve seat)

Regulating cone: DN 15 - DN 50

Regulating cage: DN 65 - DN 100

Correlation Kv value, operating pressure, regulating cone number
Valve body material: 1.4408 (code 37) and GGG 40.3 (code 90)

Nominal size	Kv value [m ³ /h]	Operating pressure [bar] *	Actuator size	Regulating cone number	
DN				linear	equal- percentage (mod.)
15	4.0	12.0	0	RS021	RS031
		40.0	1	RS020	RS030
20	6.3	6.0	0	RS022	RS032
		20.0	1	RS023	RS033
25	10.0	10.0	1	RS024	RS034
32	16.0	7.0	1	RS028	RS038
		20.0	2	RS025	RS035
40	25.0	4.5	1	RS029	RS039
		12.0	2	RS026	RS036
50	40.0	3.0	1	RS363	RS353
		10.0	2	RS027	RS037
65	63.0	7.0	2	-	RS350
80	90.0	5.0	2	-	RS351
100	140.0	2.5	2	-	RS352

* Observe the pressure / temperature correlation

Correlation Kv value, operating pressure, regulating cone number
Valve body material: 1.4408 (code 37)

Nominal size	Kv-Wert [m ³ /h]	Operating pressure [bar] **	Actuator size	Regulating cone number	
DN				linear	equal- percentage (mod.)
15	0.1*	40	1	RA101	RA301
	0.16*	40	1	RB101	RA302
	0.25*	40	1	RB102	RB302
	0.40*	40	1	RB103	RB301
	0.63*	40	1	RC101	RC301
	1.00*	40	1	RC102	RC302
	1.60	40	1	RD101	RD301
	2.50	40	1	RE101	RE301
20	1.60	40	1	RD102	RD302
	2.50	40	1	RE102	RE302
	4.00	40	1	RF101	RF301
25	2.50	40	1	RE103	RE303
	4.00	40	1	RF102	RF303
	6.30	40	1	RG101	RG301
32	4.00	40	1	RF103	RF302
	6.30	40	1	RG102	RG302
	10.00	16	1	RH102	RH301
40	6.30	40	1	RG103	RG303
	10.00	18	1	RH101	RH302
	16.00	11	1	RJ101	RJ302
50***	10.00	16	1	RH103	RH303
	16.00	12	1	RJ102	RJ301
	25.00	16	2	RK101	RK301

* metal seated (with no soft seat)

** Observe the pressure / temperature correlation

*** only for connection code 8, 39, 48

Order data

Body configuration	Code
2/2-way body	D

Connection	Code
Flanges EN 1092 / PN16 / form B, length EN 558, series 1, ISO 5752, basic series 1	8
Flanges EN 1092 / PN25 / form B, length EN 558, series 1, ISO 5752, basic series 1	10
Flanges EN 1092 / PN40 / form B, length EN 558, series 1, ISO 5752, basic series 1	11
Flanges ANSI Class 150 RF, face-to-face dimension FTF EN 558 series 1, ISO 5752, basic series 1	39
Flanges drilled according to JIS 20K (DN 15 - 40), Flanges drilled according to JIS 10K (DN 50), length EN 558, series 10, ASME/ANSI B 16.10 table 1, column 16	48

Valve body material	Code
1.4408, Investment casting	37
EN-GJS-400-18-LT (GGG 40.3) SG iron	90

Seat seal	Code
PTFE	5
PTFE, glass fibre reinforced	5G
Steel (standard up to Kv value 1.00 m ³ /h)	10*
* R-No. on request	

Control function	Code
Normally closed (NC)	1
Double acting (DA)	3*
Double acting (normally open)	8*
* R-No. on request	

Actuator size	Flow	Code
Actuator 0 piston ø 50 mm	under the seat	0
Actuator 1 piston ø 70 mm	under the seat	1
Actuator 2 piston ø 120 mm	under the seat	2

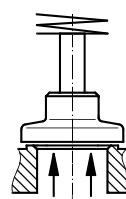

Flow under the seat

Regulating cone	R-No.
For the regulating cone no. (R-No.) - linear or equal-percentage (mod.) please refer to the table	

Version	Code
Gland packing PTFE / PTFE suitable for contact with food according to EU Regulation 1935/2004	2013

Order example	534	25	D	10	37	5	1	1	RS034	-
Type	534									
Nominal size		25								
Body configuration (code)			D							
Connection (code)				10						
Valve body material (code)					37					
Seat seal (code)						5				
Control function (code)							1			
Actuator size (code)								1		
Regulating cone (R-No.)									RS034	
Version (Code)										-

For the technical data and order data of the positioners please refer to data sheets GEMÜ 1434, 1435 and 1436. Please also note the table on the last page.

Version for food contact
For food contact, the product must be ordered with the following ordering options:
Version code 2013
Seat seal code 5, 5G, 10
Valve body material code 37

Actuator dimensions / Installation dimensions [mm]

Actuator dimensions

Actuator size	øB	M	A2	G
0 + 3	72	M16x1	70	G 1/4
1 + 4	96	M16x1	86	G 1/4
2	168	M22x1.5	149	G 1/4

Installation dimensions [mm] / weight of valve [kg]

DN	SW1 metric	Actuator size 0 + 3		Actuator size 1 + 4		Actuator size 2	
		CT	Weight	CT	Weight	CT	Weight
15	36	190	3.1	218	3.6	-	7.8
20	41	197	4.1	225	4.6	320	8.6
25	46	208	5.0	236	5.5	331	9.3
32	55	-	-	241	7.7	336	10.9
40	60	-	-	252	9.0	347	11.9
50	75	-	-	260	11.8	355	14.0
65	75	-	-	-	-	383	-
80	75	-	-	-	-	398	-
100	75	-	-	-	-	419	-

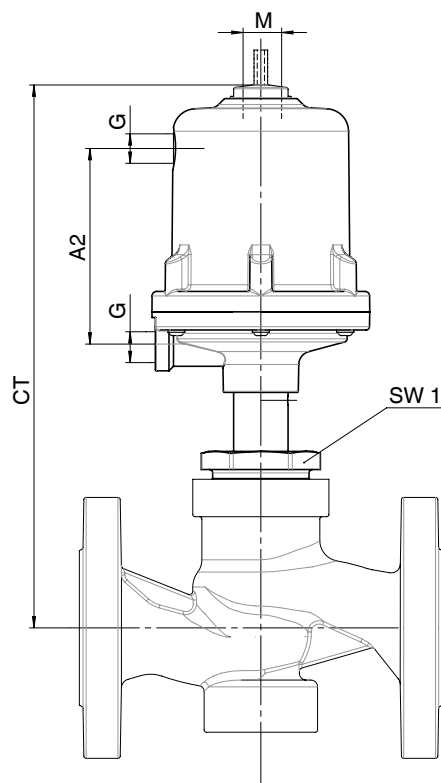

Dimensions - GEMÜ 534 [mm]

GEMÜ 534 with 1434 μ Pos

DN	Actuator size	Control function	$\varnothing B$	HAR
15	0	1	72	294
	1	1	96	322
20	0	1	72	301
	1	1	96	329
25	0	1	72	312
	1	1	96	340
32	1	1	96	345
40	1	1	96	356
50	1	1	96	364

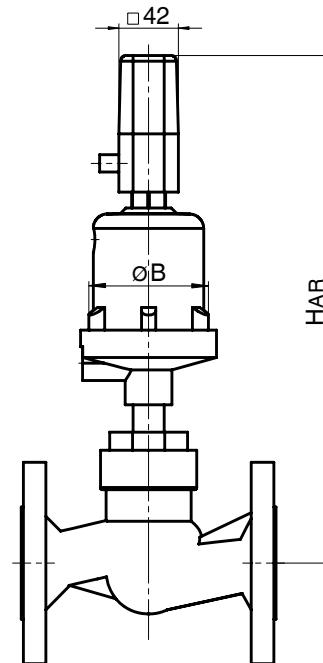

GEMÜ 534 with 1435 ePos

DN	Actuator size	Control function	øB	HAW	HAR	LAR
15	0	1	72	251	278	118
	1	1	96	279	306	118
		3 and 8	96	303	330	118
20	0	1	72	258	285	118
	1	1	96	286	313	118
		3 and 8	96	310	337	118
	2	1	168	408	413	138
3 and 8		168	427	432	138	
25	0	1	72	269	296	118
	1	1	96	297	324	118
		3 and 8	96	321	348	118
	2	1	168	419	424	138
3 and 8		168	438	443	138	
32	1	1	96	302	329	118
		3 and 8	96	326	353	118
	2	1	168	424	429	138
		3 and 8	168	443	448	138
40	1	1	96	313	340	118
		3 and 8	96	337	364	118
	2	1	168	435	440	138
		3 and 8	168	454	459	138
50	1	1	96	321	348	118
		3 and 8	96	345	372	118
	2	1	168	443	448	138
		3 u. 8	168	462	467	138
65	2	1	168	369	374	138
		3 and 8	168	388	393	138
80	2	1	168	369	374	138
		3 and 8	168	388	393	138
100	2	1	168	369	374	138
		3 and 8	168	388	393	138

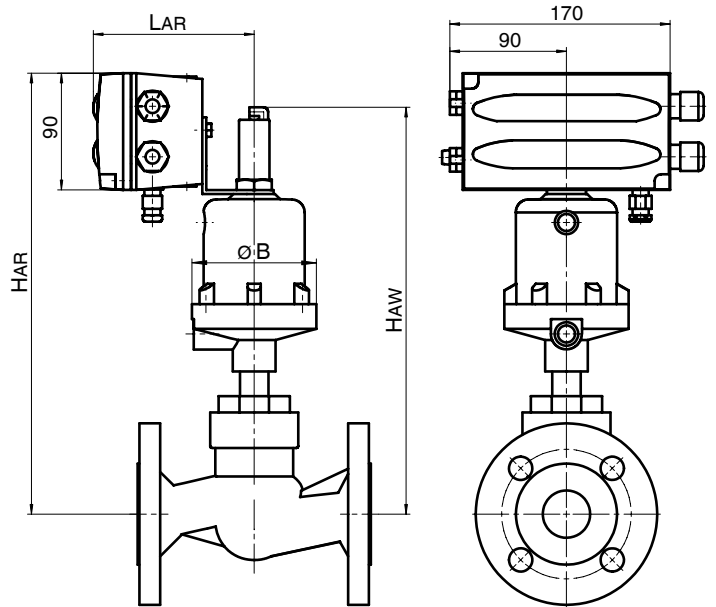

Dimensions - GEMÜ 534 [mm]

GEMÜ 534 with 1436 cPos

DN	Actuator size	Control function	øB	HAR
15	0	1, 3	72	347
	1	1	96	351
		3	96	375
20	0	1, 3	72	354
	1	1	96	358
		3	96	382
	2	1	168	480
		3	168	499
25	0	1, 3	72	365
	1	1	96	369
		3	96	393
	2	1	168	492
		3	168	510
32	1	1	96	374
		3	96	398
	2	1	168	496
		3	168	515
40	1	1	96	385
		3	96	409
	2	1	168	508
		3	168	526
50	1	1	96	393
		3	96	417
	2	1	168	516
		3	168	534
65	2	1	168	442
		3	168	460
80	2	1	168	442
		3	168	460
100	2	1	168	442
		3	168	460

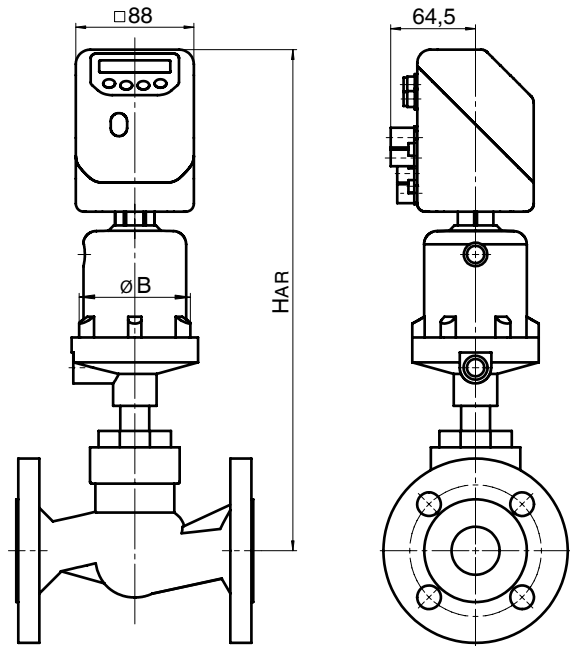

Body dimensions [mm]

Flanges, connection code 8, 10, 11, 39, 48
Valve body material 1.4408 (code 37), EN-GJS-400-18-LT (code 90)

DN	Number of bolts	Connection code 8, 10, 11				Connection code 39				Connection code 48				Weight [kg]
		FTF	ø D	ø K	ø L	FTF	ø D	ø K	ø L	FTF	ø D	ø K	ø L	
15	4	130	95	65	14	130	90	60.3	15.9	108	95	70	15	2.2
20	4	150	105	75	14	150	100	69.9	15.9	117	100	75	15	3.0
25	4	160	115	85	14	160	110	79.4	15.9	127	125	90	19	3.7
32	4	180	140	100	18	180	115	88.9	15.9	-	-	-	-	5.3
40	4	200	150	110	18	200	125	98.4	15.9	165	140	105	19	6.3
50	4	230	165	125	18	230	150	120.7	19.0	203	155	120	19	8.4

For materials see overview on page 10

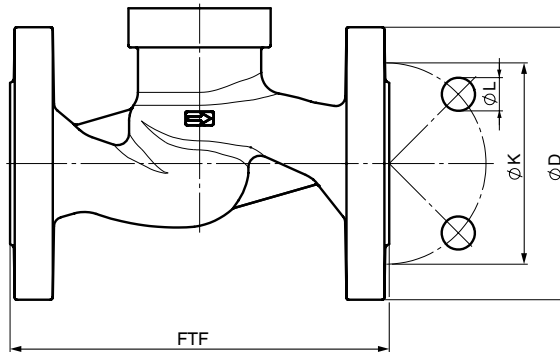

Flanges, connection code 8, 39
Valve body material 1.4408 (code 37), EN-GJS-400-18-LT (code 90)

DN	FTF	Connection code 8				Connection code 39				Weight [kg]
		ø D	ø K	ø L	Number of bolts	ø D	ø K	ø L	Number of bolts	
65	290	185	145	18	4	180	139.7	19	4	12.7
80	310	200	160	18	8	190	152.4	19	4	15.4
100	350	220	180	18	8	230	190.5	19	8	23.0

For materials see overview on page 10

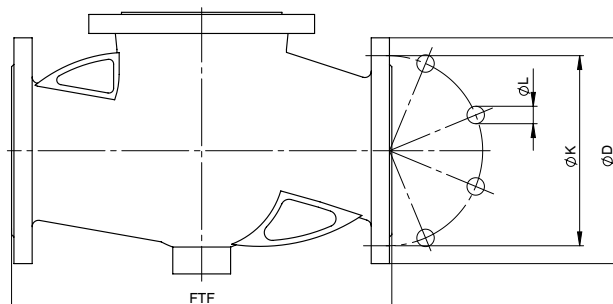

Overview of metal bodies for GEMÜ 534

Connection code	8		10	11	39		48
	37	90	37	37	37	90	37
DN 15	-	X	-	X	X	X	X
DN 20	-	X	-	X	X	X	X
DN 25	-	X	-	X	X	X	X
DN 32	-	X	X	X	X	X	-
DN 40	-	X	X	X	X	X	X
DN 50	X	X	-	X	X	X	X
DN 65	X	X	-	-	X	X	-
DN 80	X	X	-	-	X	X	-
DN 100	X	X	-	-	X	X	-

Specification sheet

for designing regulating cones for globe valves

Project (customer) _____ Valve/TAG number _____

Date _____ Telephone _____

Contact person _____ E-Mail _____

Technical requirements

Medium ¹⁾ _____

Requirement characteristic	1st operating point maximum flow		2nd operating point medium flow		3rd operating point minimum flow	
Media temperature ⁴⁾		°C		°C		°C
Inlet pressure		bar(g)		bar(g)		bar(g)
Outlet pressure		bar(g)		bar(g)		bar(g)
Flow rate ^{2, 3)}						
in [m ³ /h] for liquids		m ³ /h		m ³ /h		m ³ /h
Gases ⁶⁾		Nm ³ /h		Nm ³ /h		Nm ³ /h
in [kg/h] for steam		kg/h		kg/h		kg/h

Valve body / Actuator	Type					
	Required valve DN					
	Max. operating pressure					
	Ambient temperature ⁵⁾					
	Max. media temperature					
	Connection					
	Body material					
	Seat seal	<input type="radio"/> PTFE	<input type="radio"/> Other			
	Control function	<input type="radio"/> NC (normally closed)	<input type="radio"/> DA (double acting)	<input type="radio"/> Double acting (normally open)		
	Control pressure	min	max			
Regulating cone	Characteristic	<input type="radio"/> linear	<input type="radio"/> modified equal-percentage			
	<input type="checkbox"/> Other					

- Liquid or gas?
For media other than water or air, it is necessary to give data for the density and viscosity (with unit of measurement) of the medium. Otherwise we will assume data for standard conditions.
- For steam especially, the minimum or maximum flow rate should be assigned to the appropriate inlet or outlet pressure. The temperature of the medium should also be taken into account.
- GEMÜ recommends a positioning ratio of 1 : 10 (e.g. minimum flow rate is 10 m³/h and the maximum flow rate is 100 m³/h). Please note that the valve only controls reliably from a flow of

about 10% of the max. Kv value on account of the valve opening behaviour. Other positioning ratios are possible on request or in the selection of standard regulating cones.

- The media temperature range must be specified for steam applications. T = 20 °C is assumed unless specified otherwise.
- This data is not absolutely necessary. A room temperature of 20 °C is assumed unless specified otherwise.
- Basis: standard conditions 0 °C, 1013.25 mbar. If conditions differ, please specify them.

Positioner functions / features			
	1434 μ Pos	1435 ePos	1436 cPos
Controller type			
Positioner	X	X	X
Process controller			X
Control air flow			
Version 1	15 l/min	50 l/min	150 l/min
Version 2		90 l/min	200 l/min
Operation			
Local display / keypad		X	X
Status display	X	X	X
Web browser user			X
Field bus (Profibus DP, Device Net)			X
Signal			
24V DC / 3-wire	X	X	X
Body			
Plastic	X		X
Aluminium / industrial		X	
Functions			
Automatic initialisation	X	X	X
Alarm / error outputs		X	X
Min/max positions adjustable		X	X

GEMÜ 1434 μ Pos not available for actuator size 2

Other GEMÜ control valves



GEMÜ 514
+ 1434 μ Pos



GEMÜ 530
+ 1435 ePos



GEMÜ 532
+ 1435 ePos



GEMÜ 550
+ 1434 μ Pos



GEMÜ 554
+ 1435 ePos

For further globe valves, accessories and other products, please see our Product Range catalogue and Price List.
Contact GEMÜ.

GEMÜ VALVES, MEASUREMENT
AND CONTROL SYSTEMS

