

## GEMÜ C60 CleanStar

### Pneumatically operated diaphragm valve



#### Features

- All wetted parts made of PFA or PTFE
- High flow rate with low-stress media channelling
- Optional flow direction
- Long service life based on test results and field experience
- Ideally suited for corrosive media
- Optional version with ECTFE union nut and/or with PFA-coated compression springs
- Also available as T valve
- Clean room production, fulfils SEMI F57

#### Description

The ultra pure 2/2-way diaphragm valve GEMÜ C60 CleanStar® has a plastic piston actuator and is pneumatically operated. A stroke limiter (not with AG 4) and an optical position indicator are integrated as standard. All media wetted parts are produced from PFA or PTFE (HPW version). For the HPS version, there is a choice of valve bodies made of PP-R, natural or PVDF. This High Purity version of the CleanStar® series complies with the strictest purity standards and boasts high chemical resistance. It can also be used with high media temperatures. As such, it is often used at the supply and distribution level in semiconductor factories.

#### Technical specifications

- **Media temperature:** -10 to 150 °C
- **Ambient temperature:** 0 to 60 °C
- **Operating pressure:** 0 to 6 bar
- **Nominal sizes:** DN 4 to 50
- **Body configurations:** Straight through body | T body | V valve body
- **Connection types:** Flare | Flare SpaceSaver | Nexus Connect® SpaceSaver | PrimeLock® | PrimeLock® SpaceSaver | Spigot | Super 300 Type Pillar® SpaceSaver | Union end | Welded-on Nexus Connect®
- **Connection standards:** DIN
- **Body materials:** PFA | PP-R, natural | PVDF
- **Diaphragm materials:** PTFE/EPDM
- **Conformities:** EAC | FDA | TA Luft (German Clean Air Act)

Technical data depends on the respective configuration



**CleanStar product line**

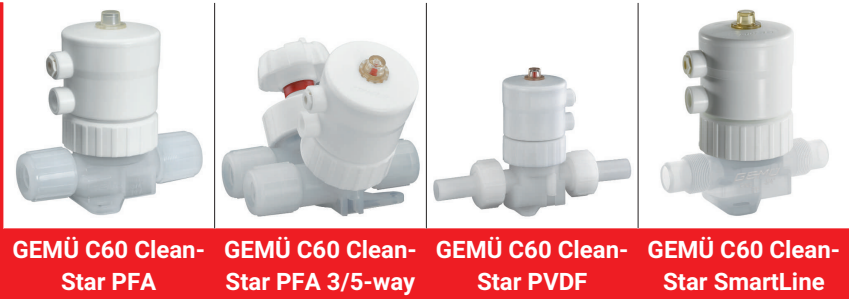

	GEMÜ C60 Clean-Star PFA	GEMÜ C60 Clean-Star PFA 3/5-way	GEMÜ C60 Clean-Star PVDF	GEMÜ C60 Clean-Star SmartLine
<b>Operation</b>				
Pneumatic	●	●	●	●
<b>Nominal sizes</b>	DN 4 Up to 50	DN 10 Up to 15	DN 15	DN 10 Up to 32
<b>Media temperature</b>	-10 Up to 150 °C	-10 Up to 150 °C	-10 Up to 120 °C	-10 Up to 80 °C
<b>Connection types</b>				
Butt weld spigot	●	-	-	●
Flare	●	●	-	●
Flare SpaceSaver	●	●	-	-
Nexus Connect® SpaceSaver	●	-	-	-
PrimeLock®	●	-	-	-
PrimeLock® SpaceSaver	●	-	-	-
Super 300 Type Pillar® SpaceSaver	●	-	-	-
Tube spigot	●	-	-	-
Union end	-	-	●	●
Welded-on Nexus Connect®	●	-	-	-
<b>Body materials</b>				
PFA	●	●	-	-
PP-R	-	-	-	●
PVDF	-	-	●	-
<b>Body configuration</b>				
Straight through body	●	-	●	●
T body	●	-	-	-
V valve body	-	●	-	-
<b>Conformities</b>				
EAC	●	●	●	●
FDA	●	●	●	●
TA Luft (German Clean Air Act)	●	●	●	●

## Product description





No.	Name	Materials
1	Stroke limiter and optical position indicator	
2	Actuator	PVDF (body)
3	Pneumatic connections	
4	Actuator union nut	PVDF or ECTFE
5	Union nut connections	PVDF, PFA or CPFA
6	Lifting lugs	
7	Leak detection hole	
8	Valve body	PVDF, PFA or PP-R, natural
	Diaphragms (internal)	PTFE (media wetted)/EPDM

## Designs

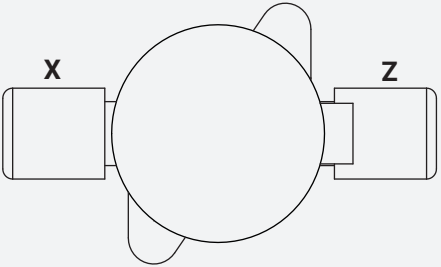
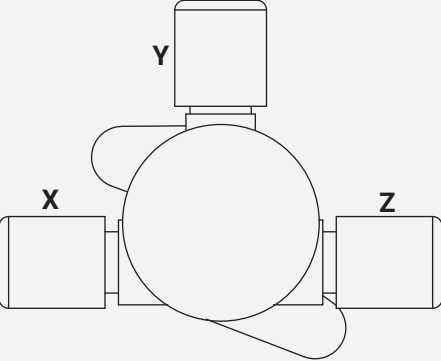
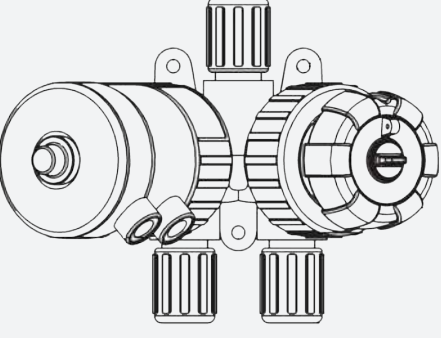
### Body configurations

Body configuration	Description
<p data-bbox="213 333 464 362"><b>2/2-way body (code D)</b></p> 	<p data-bbox="572 333 1476 488">The 2/2-way body is the most commonly used body configuration. Thanks to the seal created by the weir-style body, the flow direction is freely selectable. Various pipe and tube connections can be connected to the ports, whereby both connections (X and Z) have the same connection size. However, different connection sizes can also be used by attaching corresponding fittings.</p>
<p data-bbox="220 651 458 680"><b>T valve body (code T)</b></p> 	<p data-bbox="572 651 1458 775">The T body has 3 connections. The opposing connections (X and Z) are classed as main pipe, as media flows between them at all times, regardless of the position (open/closed) of the actuator. The branch (Y) is located at a 90° angle to the main pipe. The flow across this connection can be influenced via the actuator.</p> <p data-bbox="572 786 1458 940">T valves are often used when regular analyses of the medium are required. To this end, the branch (Y) is opened briefly to remove a small volume of the medium as and when necessary. T valves are often also installed in a ring main, whereby the medium from the ring main is only released via the Y connection when the actuator is in its open position.</p>
<p data-bbox="248 1066 429 1095"><b>V valve (code V)</b></p> 	<p data-bbox="572 1066 1437 1126">The V valve body has 3 connections, two of which (X and Z) can be controlled via valve seats. The following flow schemes can therefore be implemented:</p> <ul data-bbox="572 1137 1374 1283" style="list-style-type: none"> <li>• Flow between X and Y, as well as between Z and Y (both actuators open)</li> <li>• No flow (both actuators closed)</li> <li>• Flow only between X and Y (one actuator open, one actuator closed)</li> <li>• Flow only between Z and Y (one actuator open, one actuator closed)</li> </ul> <p data-bbox="572 1294 1476 1355">This diaphragm valve can be configured with two pneumatic and two manual actuators. A combination of both actuator types is also possible.</p> <p data-bbox="572 1366 1461 1449">V valves are often used when media need to be mixed at a specific mixing ratio. However, they can also be used to establish redundant media supply or as a mixing valve.</p>

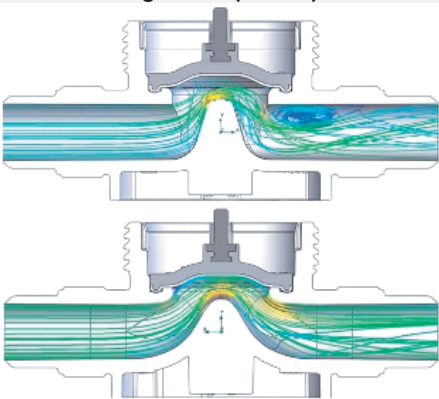
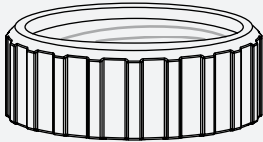
Special versions

	Description
<p><b>High Flow (code F)</b></p> 	<p>In actuator sizes 2 and 3, the 2/2-way body is also available in what is known as a High Flow design. This body version has a flow-optimized weir geometry. This reduces the pressure loss and thereby facilitates a higher flow. High Flow valve bodies are often used when higher volume flows are required.</p> <p>The upper image shows a cross-section of a standard version without High Flow. The lower image shows a cross-section of a High Flow design (code F).</p>
<p><b>ECTFE union nut (code E)</b></p> 	<p>The central union nut, which connects the actuator to the body via a thread, can optionally be ordered in ECTFE form. This design is used if the outside environment where the valve is used contains alkaline media. In conditions such as these, a central union nut made from ECTFE can offer improved mechanical and chemical resistance. The materials can be distinguished based on their colour. In comparison with the white PVDF material, ECTFE has a slightly darker colour. The material is also uniquely indicated via an arrow on the union nut.</p>
<p><b>PFA-coated spring (design 7030)</b></p> 	<p>When operating in an environment that favours corrosion or otherwise impairs the function of metallic parts, use of a pneumatic valve is unavoidable in certain cases. The PFA coating of the spring can therefore make sense, as it helps maintain functionality.</p> <p><b>The availability of this option must be checked on request.</b></p>

# GEMÜ C60 CleanStar PFA

*Pneumatically operated diaphragm valve with PFA valve body*



## Features

- All wetted parts made of PFA or PTFE
- High flow rate with low-stress media channelling
- Optional flow direction
- Long service life based on test results and field experience
- Ideally suited for corrosive media
- Optional version with ECTFE union nut and/or with PFA-coated compression springs
- Also available as T valve
- Clean room production, fulfils SEMI F57

---

## Description

The ultra pure 2/2-way diaphragm valve GEMÜ C60 CleanStar® has a plastic piston actuator and is pneumatically operated. A stroke limiter (not with AG 4) and an optical position indicator are integrated as standard. All media wetted parts are produced from PFA or PTFE (HPW version). For the HPS version, there is a choice of valve bodies made of PP-R, natural or PVDF. This High Purity version of the CleanStar® series complies with the strictest purity standards and boasts high chemical resistance. It can also be used with high media temperatures. As such, it is often used at the supply and distribution level in semiconductor factories.

## Technical specifications

- **Media temperature:** -10 to 150 °C
- **Ambient temperature:** 0 to 60 °C
- **Operating pressure:** 0 to 6 bar
- **Nominal sizes:** DN 4 to 50
- **Body configurations:** Straight through body | T body
- **Connection types:** Butt weld spigot | Flare | Flare SpaceSaver | Nexus Connect® SpaceSaver | PrimeLock® | PrimeLock® SpaceSaver | Super 300 Type Pillar® SpaceSaver | Tube spigot | Welded-on Nexus Connect®
- **Connection standards:** DIN
- **Body materials:** PFA
- **Diaphragm materials:** PTFE/EPDM
- **Conformities:** EAC | FDA | TA Luft (German Clean Air Act)

Technical data depends on the respective configuration

## Availability C60 PFA

### Body configuration - 2/2-way body (code D)

#### Materials

International code	DN	Connection size X, Z	Connection type (code) <sup>1)</sup>			
			30	NX welded	NX SpaceSaver	73, 75, 77, PL, T3
			PFA material (code 30)			
4	4	1/4" tube	-	X	-	X
	10	1/4" pipe	X	-	-	-
6	6	3/8" tube	-	X	X	X
8	10	1/2" tube	-	X	X	X
	15	1/2" pipe	X	-	-	-
12	15	3/4" tube	-	X	X	X
	20	3/4" pipe	X	-	-	-
16	20	1" tube	-	X	X	X
	25	1" pipe	X	-	-	-
20	25	1¼" tube	-	-	-	X
24	40	1½" pipe	X	-	-	-
32	50	2" pipe	X	-	-	-

#### 1) Connection type

Code 30: Spigot – inch, for welding or solvent cementing, depending on the body material

Code 73: Flare connection with CPFA union nut

Code 75: Flare connection with PVDF union nut

Code 77: Flare connection with PFA union nut

Code NX: Nexus Connect connection with PFA union nut

Code PL: PrimeLock connection

Code T3: Tube spigot

## Connections

### Body configuration - 2/2-way body (code D)

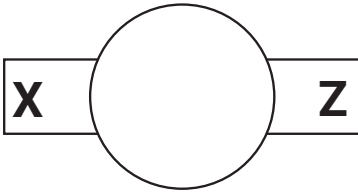

#### Connection type Flare (code 73, 75, 77)

Actuator size (code)	Connection size (code)	SpaceSaver position			
		None	On one side Pos. X	On one side Pos. Z (code Z)	On both sides Pos. X, Z (code S)
1, 1E	4	X	On request	X	-
	6	X	On request	X	-
2, 2E	8	X	On request	X	X
	12	X	On request	X	X
3, 3E	12	X	On request	X	X
	16	X	On request	X	X
	20	X	On request	X	X

#### Connection type Flare (code 73, 75, 77) – High Flow design

Actuator size (code)	Connection size (code)	SpaceSaver position			
		None	On one side Pos. X	On one side Pos. Z (code Z)	On both sides Pos. X, Z (code S)
2 F, 2EF	12	X	On request	-	-
2 F, 2EF	16	X	On request	-	-
3 F, 3EF	16	X	On request	-	-
3 F, 3EF	20	X	On request	X	X

#### Butt weld spigot connection type (code 30)

Actuator size (code)	Connection size X, Z (code)	Butt weld spigot	
		On both sides	On one side, pos. Z
1, 1E	4	X	-
2, 2E	8	X	X
2, 2E	12	X	X
3, 3E	12	X	X
3, 3E	16	X	X
4, 4E	24	X	-
4, 4E	32	X	-

#### Connection type butt weld spigot (code 30) - High Flow design

Actuator size (code)	Connection size X, Z (code)	Butt weld spigot	
		On both sides	On one side, pos. Z
2 F	8	X	-
2 F	12	X	-
3 F	16	X	-

## Connection type Flare in pos. X, butt weld spigot in pos. Z (code K)

Actuator size (code)	Actuator size (code)	Connection type (code)	
		73, 75, 77	30
		On one side, pos. X	On one side, pos. Z
2, 2E	8	X	X
2, 2E	12	X	X
3, 3E	12	X	X
3, 3E	16	X	X

## Connection type Flare in pos. X, butt weld spigot in pos. Z (code K) – High Flow design

Actuator size (code)	Actuator size (code)	Connection type (code)	
		73, 75, 77	30
		On one side, pos. X	On one side, pos. Z
2 F, 2EF	12	X	X
2 F, 2EF	16	X	X
3 F, 3EF	16	X	X

## PrimeLock® connection type (code PL)

Actuator size (code)	Connection size (code)	Pos. SpaceSaver
		Without
1, 1E	4	X
	6	X
2, 2E	8	X

## PrimeLock® (code PL) connection type – High Flow design

Actuator size (code)	Connection size (code)	Pos. SpaceSaver
		Without
2 F, 2EF	12	X
	16	X
3 F, 3EF	16	X
	20	X

## Connection type tube spigot (code T3)

Actuator size (code)	Connection size (code)	SpaceSaver position
		None
1, 1E	6	X
2, 2E	8	X
	12	X
3, 3E	16	X

## Connection type tube spigot (code T3) – High Flow design

Actuator size (code)	Connection size (code)	SpaceSaver position
		None
3 F, 3EF	20	X

## Nexus Connect® connection type (code NX) – Standard (1, 2, 3), High Flow design (2F, 3F)

Actuator size (code)	Connection size	Connection	
		On both sides	
		Welded	Space Saver
1	X, Z 1/4"	X	-

Availability C60 PFA

Actuator size (code)	Connection size	Connection	
		On both sides	
	X, Z	Welded	Space Saver
	<b>3/8"</b>	X	X
<b>2</b>	<b>1/2"</b>	X	X
	<b>3/4"</b>	X	-
<b>2F</b>	<b>3/4"</b>	X	X
	<b>1"</b>	-	X
<b>3</b>	<b>1"</b>	X	-
<b>3F</b>	<b>1"</b>	X	X

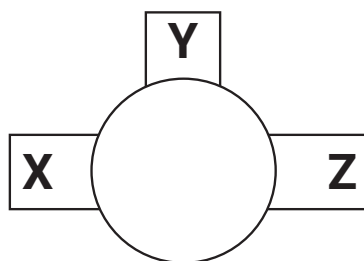
**Body configuration - T body (code T)**

X→Z: Main pipe  
(Flow even when valve is closed)  
X→Y: Branch  
(Flow only when valve is open)

**Flare connection type (code 73, 75, 77)**

Actuator size (code)	Connection size X, Z (code)	Connection size Y (code)	Space saver position				
			Without	X	Y	Z	X, Z (code S)
1, 1E	6	4	X	-	-	-	-
	6	6	X	-	-	-	-
	8	6	X	-	-	X	-
	12	6	X	-	-	X	-
2, 2E	8	8	X	X	X	X	-
	12	8	X	X	X	X	X
	12	12	X	X	X	X	-
	16	8	X	X	-	X	X
	16	12	X	X	-	X	-
3, 3E	16	16	X	X	-	-	-
	20	8	X	-	-	X	-
	20	12	X	-	-	-	-
	20	16	X	-	-	-	-
	20	20	X	-	-	X	-

**Butt weld spigot connection type (code 30)**

Actuator size (code)	Connection size X, Z (code)	Connection size Y (code)	Butt weld spigot, pos. X, Y, Z	Butt weld spigot, pos. X, Z	
				Space saver, pos. Y	Flare connection, pos. Y
1, 1E	4	4	X	-	-
	8	4	X	-	-
2, 2E	8	8	X	X	-
	12	8	X	-	-
	12	8	X	-	X
	12	12	-	-	X
3, 3E	16	8	X	-	X
	16	12	X	-	-
	16	16	X	-	X

## Order data C60 PFA

### Order data - body configuration - 2/2-way body (code D)

#### Order codes

The order data provide an overview of standard configurations.

Please check the availability before ordering. Other configurations available on request.

1 Type	Code
Diaphragm valve, pneumatically operated, plastic piston actuator, optical position indicator, stroke limiter (for actuator size 1–3 only)	C60

2 Position of SpaceSaver	Code
Without	
Flare connection in position X, butt weld spigot in position Z	K
SpaceSaver for X+ Z position	S
SpaceSaver for Z position	Z

3 Connection size	Code
1/4", international code: 4	4
3/8", international code: 6	6
1/2", international code: 8	8
3/4", international code: 12	12
1", international code: 16	16
1 1/4", international code: 20	20
1 1/2", international code: 24	24
2", international code: 32	32

4 Body configuration	Code
2/2-way body	D

5 Connection type	Code
<b>Tube</b>	
Flare connection with CPFA union nut	73
Flare connection with PVDF union nut	75
Flare connection with PFA union nut	77
Nexus Connect connection with PFA union nut	NX
PrimeLock connection	PL
Tube spigot	T3
<b>Pipe</b>	
Spigot – inch, for welding or solvent cementing, depending on the body material	30

6 Valve body material	Code
PFA, perfluoroalkoxy	30

7 Diaphragm material	Code
PTFE/EPDM one-piece	54
PTFE/EPDM two-piece	5M

8 Control function	Code
Normally closed (NC)	1
Normally open (NO)	2

9 Actuator version	Code
<b>Standard version</b>	
Actuator size 1	1
Actuator size 2	2
Actuator size 3	3
Actuator size 4	4
<b>Standard version with ECTFE union nut</b>	
Actuator size 1, with ECTFE union nut	1E
Actuator size 2, with ECTFE union nut	2E
Actuator size 3, with ECTFE union nut	3E
Actuator size 4, with ECTFE union nut	4E
<b>High Flow design</b>	
Actuator size 2 High Flow	2 F
Actuator size 3 High Flow	3 F
<b>High Flow design with ECTFE union nut</b>	
Actuator size 2 High Flow, with ECTFE union nut	2EF
Actuator size 3 High Flow, with ECTFE union nut	3EF

10 Design	Code
Without	
CleanStar with welded-on NexusConnect fitting	2591
C60, spring, PFA-coated (on request)	7030

11 High Purity version	Code
High purity white	HPW

**Order example**

Ordering option	Code	Description
1 Type	C60	Diaphragm valve, pneumatically operated, plastic piston actuator, optical position indicator, stroke limiter (for actuator size 1–3 only)
2 Position of SpaceSaver	Z	SpaceSaver for Z position
3 Connection size	8	1/2", international code: 8
4 Body configuration	D	2/2-way body
5 Connection type	75	Flare connection with PVDF union nut
6 Valve body material	30	PFA, perfluoroalkoxy
7 Diaphragm material	54	PTFE/EPDM one-piece
8 Control function	1	Normally closed (NC)
9 Actuator version	2	Actuator size 2
10 Design		Without
11 High Purity version	HPW	High purity white

## Order data - body configuration - T body (code T)

### Order codes

The order data provide an overview of standard configurations.

Please check the availability before ordering. Other configurations available on request.

1 Type	Code
Diaphragm valve, pneumatically operated, plastic piston actuator, optical position indicator, stroke limiter (for actuator size 1–3 only)	C60

2 Position of SpaceSaver	Code
Without	
SpaceSaver for Y position	Y

3 Connection size	Code
Position Y	
1/4", international code: 4	4
3/8", international code: 6	6
1/2", international code: 8	8
3/4", international code: 12	12
1", international code: 16	16
1 1/4", international code: 20	20

4 Body configuration	Code
T-body	T

5 Connection type	Code
Tube	
Flare connection with CPFA union nut	73
Flare connection with PVDF union nut	75
Flare connection with PFA union nut	77
Pipe	
Spigot – inch, for welding or solvent cementing, depending on the body material	30

6 Valve body material	Code
PFA, perfluoroalkoxy	30

7 Diaphragm material	Code
PTFE/EPDM one-piece	54

8 Control function	Code
Normally closed (NC)	1
Normally open (NO)	2

9 Actuator version	Code
Standard version	
Actuator size 1	1
Actuator size 2	2
Actuator size 3	3
Standard version with ECTFE union nut	
Actuator size 1, with ECTFE union nut	1E

9 Actuator version	Code
Actuator size 2, with ECTFE union nut	2E
Actuator size 3, with ECTFE union nut	3E

10 Position of SpaceSaver-2	Code
SpaceSaver for X position	X
SpaceSaver for Z position	Z
SpaceSaver for X+ Z position	S

11 Connection size 2	Code
Position X and Z	
1/4", international code-2: 4	4
3/8", international code-2: 6	6
1/2", international code-2: 8	8
3/4", international code-2: 12	12
1", international code-2: 16	16
1 1/4", international code-2: 20	20

12 Connection type spigot 2	Code
Tube	
Flare connection with CPFA union nut	73
Flare connection with PVDF union nut	75
Flare connection with PFA union nut	77
Pipe	
Spigot – inch, for welding or solvent cementing, depending on the body material	30

13 Design	Code
Without	
C60, spring, PFA-coated (on request)	7030

14 High Purity version	Code
High purity white	HPW

**Order example**

Ordering option	Code	Description
1 Type	C60	Diaphragm valve, pneumatically operated, plastic piston actuator, optical position indicator, stroke limiter (for actuator size 1–3 only)
2 Position of SpaceSaver	Y	SpaceSaver for Y position
3 Connection size	8	1/2", international code: 8
4 Body configuration	T	T-body
5 Connection type	75	Flare connection with PVDF union nut
6 Valve body material	30	PFA, perfluoroalkoxy
7 Diaphragm material	54	PTFE/EPDM one-piece
8 Control function	1	Normally closed (NC)
9 Actuator version	2	Actuator size 2
10 Position of SpaceSaver-2	Z	SpaceSaver for Z position
11 Connection size 2	8	1/2", international code-2: 8
12 Connection type spigot 2	75	Flare connection with PVDF union nut
13 Design		Without
14 High Purity version	HPW	High purity white

## Technical data C60 PFA

### Medium

**Working medium:** Gaseous and liquid media (specified in the table below based on nominal size) – in particular high-purity media – which have no negative impact on the physical and chemical properties of the body and diaphragm material. Inert gases are excluded.

#### Categorisation

Max. permissible operating pressure (PS)	Permissible working media/fluids acc. to nominal size			
	Group 1 fluids (hazardous)		Group 2 fluids (other)	
	Gases (diagram 6)	Liquids (diagram 8)	Gases (diagram 7)	Liquids (diagram 9)
<b>6 bar</b>	Up to max. 1"/DN25		> 1"/DN25	

### Temperature

**Media temperature:** PFA valve body material (code 30): -10 – 150 °C  
Observe pressure/temperature diagram

**Ambient temperature:** 0 – 60 °C

**Storage temperature:** 0 – 40 °C

### Pressure

**Operating pressure:** 0 – 6 bar  
applied upstream

Pressure/temperature diagram:

Valve body material: PFA (code 30), actuator sizes 1, 2 and 3

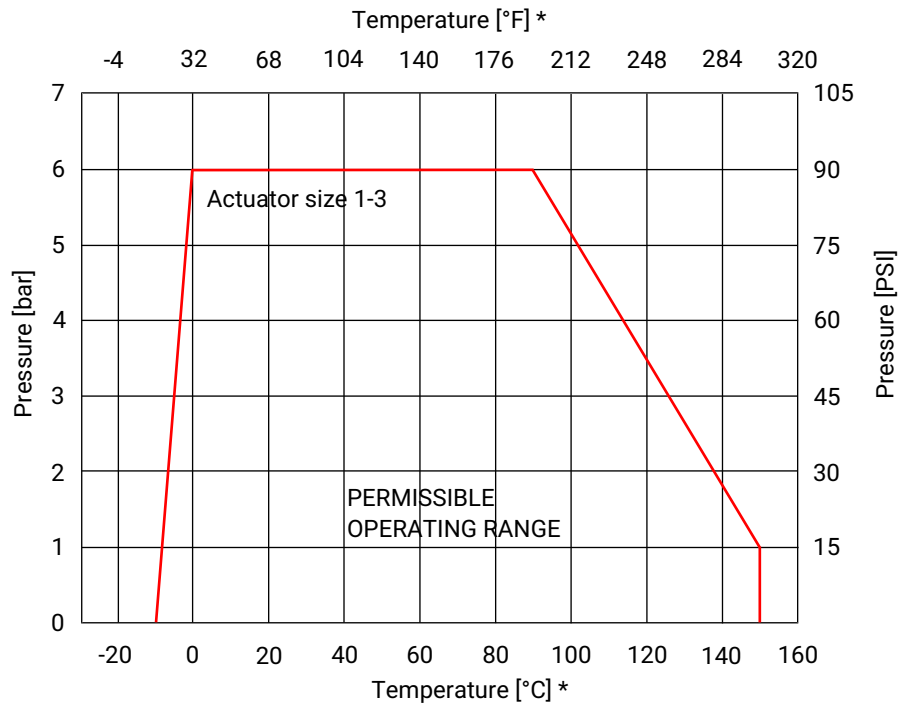

Valve body material: PFA (code 30), actuator sizes 4, 4E

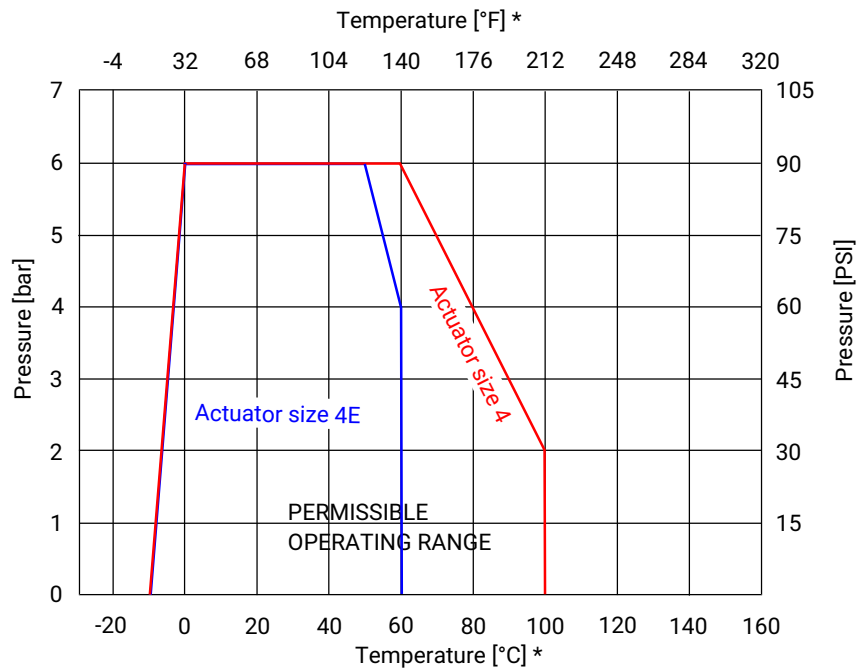

\* **Note:** The temperature/pressure diagram is only an aid. The data refers to water as a working medium. A change of operating conditions or other media may result in deviations. In case of doubt, it is advisable to test the behaviour of the material under the definitive operating conditions in a test installation. Temperatures below 0 °C can have a negative influence on the actuation speed. The pressure-bearing valve bodies are designed to maintain their functionality unchanged for a theoretical time period of 25 years. Continuously rising medium temperatures would change this time period as follows:

- 24.4 years at 110 °C
- 8.2 years at 120 °C
- 3.4 years at 130 °C
- 1.4 years at 140 °C
- 1.0 year at 150 °C

**Kv values:**

**Body configuration – 2/2-way body (code D)**

Actuator size (code)	Connection size X, Z	Connection	
		On both sides	
		Hose connection	Pipe connection
<b>1, 1E</b>	1/4"	4.0	15.0
	3/8"	15.0	-
<b>2, 2E</b>	1/2"	35.0	68.0
	3/4"	68.0	68.0
<b>3, 3E</b>	3/4"	68.0	126.0
	1"	158.0	175.0
	1¼"	170.0	-
<b>4, 4E</b>	1½ "	-	1225.0
	2"	-	1225.0

Kv values in l/min

If the 2/2-way body has a tube and pipe connection, the Kv values of the tube connection are used.

**Body configuration - 2/2-way body (code D) – High Flow design**

Actuator size (code)	Connection size X, Z	Connection	
		On both sides	
		Tube connection	Pipe connection
<b>2 F, 2EF</b>	1/2"	-	115.0
	3/4"	115.0	115.0
	1"	123.0	123.0
<b>3 F, 3EF</b>	1"	316.0	316.0
	1¼"	325.0	-

Kv values in l/min

**Body configuration – 2/2-way body (code D) – Nexus Connect® connection type (code NX)**

Actuator size (code)	Connection size X, Z	Connection	
		On both sides	
		Welded	SpaceSaver
<b>1</b>	1/4"	7.82	-
	3/8"	13.0	13.3
<b>2</b>	1/2"	48.1	35.2
	3/4"	66.3	-
<b>2F</b>	3/4"	-	110.0
<b>3</b>	1"	142.0	-
<b>3F</b>	1"	-	255.0

Kv values in l/min

**Kv values:**
**Body configuration - T body (code T)**

Actuator size (code)	Connection size		Connection		
			On both sides at main pipe (X, Z) and branch (Y)		One side
	Main pipe X, Z	Branch Y	Tube connec- tion	Pipe connec- tion	Pipe/tube connec- tion
<b>1, 1E</b>	1/4"	1/4"	-	17.0	-
	3/8"	1/4"	4.0	-	-
	3/8"	3/8"	13.0	-	-
	1/2"	1/4"	-	18.0	-
	1/2"	3/8"	17.0	-	-
	3/4"	3/8"	18.0	-	-
<b>2, 2E</b>	1/2"	1/2"	28.0	62.0	36.0
	3/4"	1/4"	-	35.0	-
	3/4"	1/2"	35.0	38.0	38.0
	3/4"	3/4"	62.0	71.0	-
	1"	1/2"	38.0	101.0	-
	1"	3/4"	71.0	-	-
<b>3, 3E</b>	1"	1"	137.0	135.0	145.0
	1"	1/2"	-	101.0	42.0
	1"	3/4"	-	130.0	-
	1¼"	1/2"	53.0	-	-
	1¼"	3/4"	117.0	-	-
	1¼"	1"	150.0	-	-
	1¼"	1¼"	170.0	-	-

At branch Y

Kv values in l/min

**Vacuum:**

400 mbar absolute

The service life of the valve may be affected if exposed to a greater vacuum or when valves are installed on the pump suction side.

**Pneumatic actuator**

**Control pressure:**

Control function	Actuator size	Control pressure
1	1, 1E	4.5–7 bar
	2, 2E, 2 F, 2EF	4–7 bar
	3, 3E, 3 F, 3EF	4.5–7 bar
	4, 4E	5–7 bar
2	1, 1E, 2, 2E, 2 F, 2EF, 3, 3E, 3 F, 3EF	Max. 5 bar
	4, 4E	Max. 4.5 bar

**Control pressure / operating pressure characteristics:**

**Control function 2 – normally open (NO)**

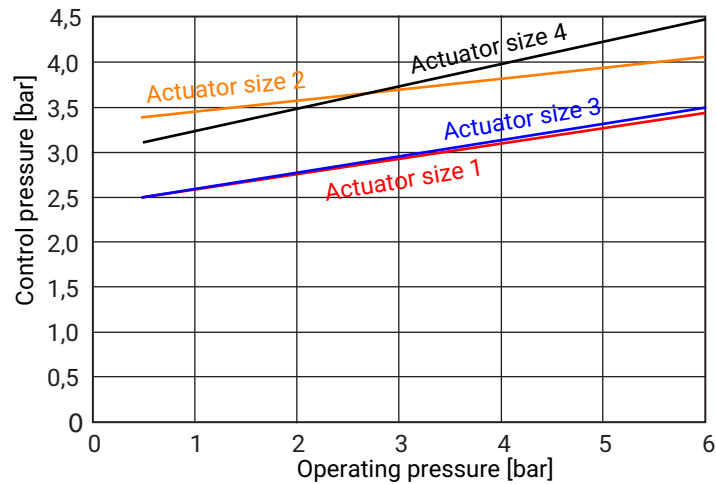

**Control air connection:**

G 1/8

**Filling volume:**

Actuator size	Control function	
	Normally closed (NC)	Normally open (NO)
1, 1E	18.0	15.0
2, 2E, 2 F, 2EF	29.0	42.5
3, 3E, 3 F, 3EF	63.0	95.0
4, 4E	146.0	794.0

Filling volume in cm<sup>3</sup>

**Product conformities**

<b>Machinery Directive:</b>	2006/42/EC
<b>Food:</b>	FDA
<b>EAC:</b>	The product is certified according to EAC.
<b>Pressure Equipment Directive:</b>	Categorisation in accordance with 2014/68/EU Article 4 and Annex II Max. category <b>GIP</b> (sound engineering practice)

**Mechanical data**

<b>Flow direction:</b>	Optional
------------------------	----------

## Dimensions C60 PFA

### 2/2-way valves (code D)

#### Flare connection (code 73, 75, 77)

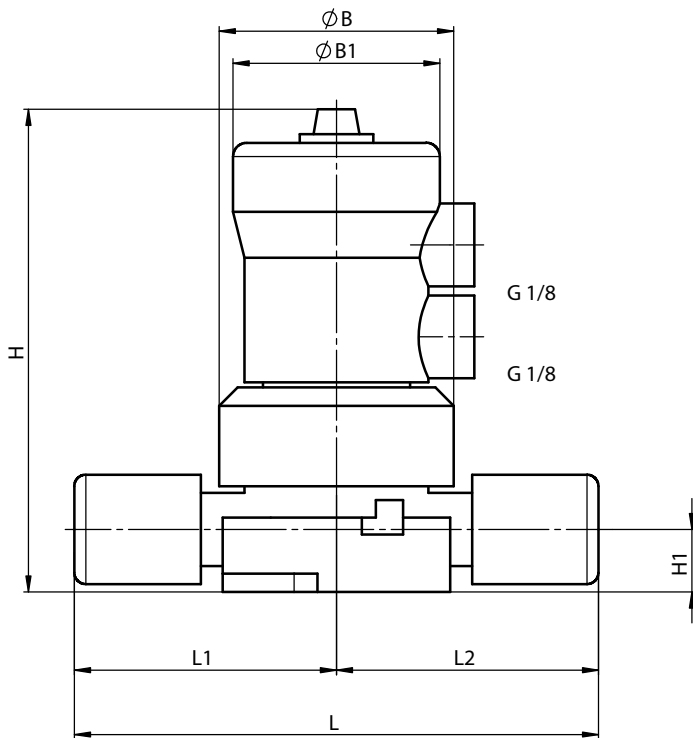

Actuator size <sup>1)</sup>	Connection size	SpaceSaver pos. <sup>2)</sup>	ØB	ØB1	H	H1	L	L1	L2
1, 1E	1/4"	-	51.4	45.0	105.0	13.6	112.8	56.4	56.4
1, 1E	1/4"	Z	51.4	45.0	105.0	13.6	120.1	56.4	63.7
1, 1E	3/8"	-	51.4	45.0	105.0	13.6	114.0	57.0	57.0
1, 1E	3/8"	Z	51.4	45.0	105.0	13.6	119.4	57.0	62.4
2, 2E	1/2"	K	64.0	64.7	126.5	19.0	133.4	65.9	67.5
2, 2E	1/2"	-	64.0	64.7	120.5	16.0	131.8	65.9	65.9
2, 2E	1/2"	S	64.0	64.7	120.5	16.0	142.0	71.0	71.0
2, 2E	1/2"	Z	64.0	64.7	120.5	16.0	136.9	65.9	71.0
2, 2E	3/4"	K	64.0	64.7	126.5	19.0	134.4	66.9	67.5
2, 2E	3/4"	-	64.0	64.7	126.5	19.0	133.8	66.9	66.9
2, 2E	3/4"	S	64.0	64.7	126.5	19.0	156.8	78.4	78.4
2, 2E	3/4"	Z	64.0	64.7	126.5	19.0	145.3	66.9	78.4
3, 3E	3/4"	-	80.0	86.8	166.5	25.0	165.8	82.9	82.9
3, 3E	3/4"	K	80.0	86.0	166.5	25.0	165.9	82.9	83.0
3, 3E	1"	K	80.0	86.8	166.5	25.0	172.5	89.5	83.0
3, 3E	1"	-	80.0	86.8	166.5	25.0	179.0	89.5	89.5
3, 3E	1"	S	80.0	86.8	166.5	25.0	188.9	89.5	99.4
3, 3E	1"	Z	80.0	86.8	166.5	25.0	188.9	89.5	99.4
3, 3E	1 1/4"	-	80.0	86.8	166.5	25.0	238.4	119.2	119.2
2 F, 2EF	3/4"	-	64.0	64.7	126.5	19.0	133.8	66.9	66.9
2 F, 2EF	3/4"	S	64.0	64.7	126.5	19.0	156.8	78.4	78.4
2 F, 2EF	3/4"	Z	64.0	64.7	126.5	19.0	145.3	66.9	78.4

Actuator size <sup>1)</sup>	Connection size	SpaceSaver pos. <sup>2)</sup>	ØB	ØB1	H	H1	L	L1	L2
<b>2 F, 2EF</b>	<b>1"</b>	-	64.0	64.7	126.5	19.0	160.0	74.0	74.0
<b>3 F, 3EF</b>	<b>1"</b>	-	80.0	86.8	166.5	25.0	179.0	89.5	89.5
<b>3 F, 3EF</b>	<b>1"</b>	<b>S</b>	80.0	86.8	166.5	25.0	198.8	99.4	99.4
<b>3 F, 3EF</b>	<b>1"</b>	<b>Z</b>	80.0	86.8	166.5	25.0	188.9	89.5	99.4
<b>3 F, 3EF</b>	<b>1¼"</b>	-	80.0	86.8	166.5	25.0	197.4	119.2	119.2

Dimensions in mm

1) **Actuator version**

Code 1: Actuator size 1

Code 1E: Actuator size 1, with ECTFE union nut

Code 2: Actuator size 2

Code 2 F: Actuator size 2 High Flow

Code 2E: Actuator size 2, with ECTFE union nut

Code 2EF: Actuator size 2 High Flow, with ECTFE union nut

Code 3: Actuator size 3

Code 3 F: Actuator size 3 High Flow

Code 3E: Actuator size 3, with ECTFE union nut

Code 3EF: Actuator size 3 High Flow, with ECTFE union nut

2) **Position of SpaceSaver**

Code K: Flare connection in position X, butt weld spigot in position Z

Code S: SpaceSaver for X+ Z position

Code Z: SpaceSaver for Z position

**Butt weld spigot (code 30)**

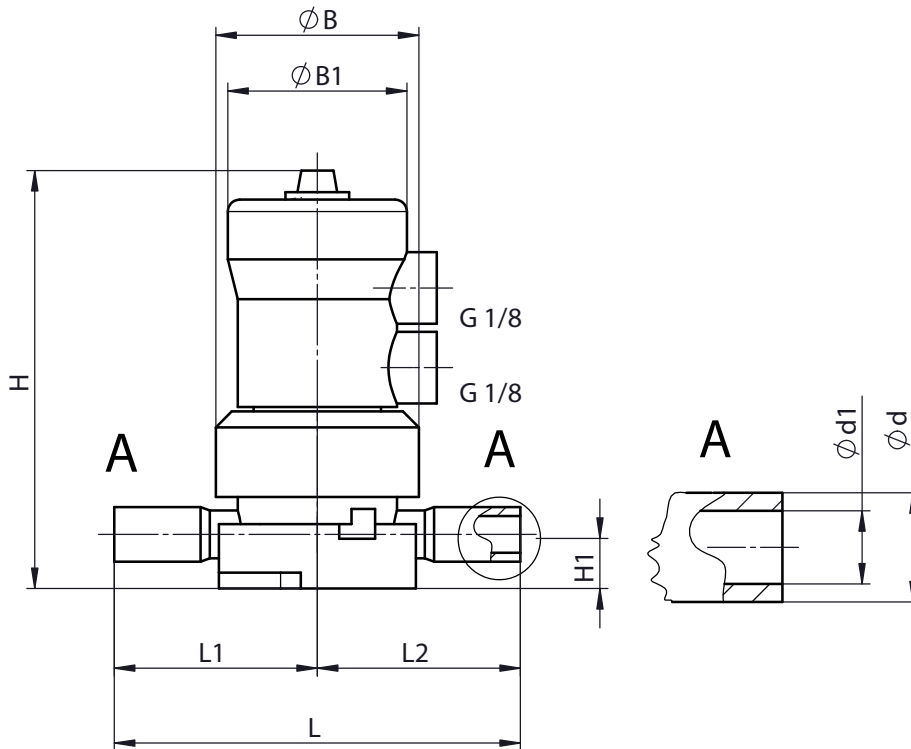

Actuator size <sup>1)</sup>	Connection size	SpaceSaver pos. <sup>2)</sup>	ØB	ØB1	H	H1	L	L1	L2	Spigot (A)	
										ød	ød1
1, 1E	1/4"	-	51.4	45.0	105.0	13.6	100.5	50.3	50.3	13.7	9.2
2, 2E	1/2"	-	64.0	64.7	126.5	19.0	135.0	67.5	67.5	21.3	15.8
2, 2E	3/4"	-	64.0	64.7	126.5	19.0	135.0	67.5	67.5	26.7	20.3
3, 3E	3/4"	-	80.0	86.8	166.0	25.0	165.5	82.8	82.8	26.7	20.3
3, 3E	1"	-	80.0	86.8	166.0	25.0	163.5	81.8	81.8	33.4	26.6
4, 4E	1 1/2"	-	132.3	153.0	349.6	40.0	194.0	97.0	97.0	48.3	40.9
4, 4E	2"	-	132.3	153.0	349.6	40.0	224.0	112.0	112.0	60.3	52.3
High Flow											
2 F, 2EF	1/2"	-	64.0	64.7	126.5	19.0	136.5	68.3	68.3	21.3	15.8
2 F, 2EF	3/4"	-	64.0	64.7	126.5	19.0	135.0	67.5	67.5	26.7	20.3
2 F, 2EF	1"	-	64.0	64.7	126.5	19.0	147.5	73.8	73.8	33.4	26.6
3F, 3EF	1"	-	80.0	86.8	166.0	25.0	166.0	83.0	83.0	33.4	26.6

Dimensions in mm

1) **Actuator version**

- Code 1: Actuator size 1
- Code 1E: Actuator size 1, with ECTFE union nut
- Code 2: Actuator size 2
- Code 2 F: Actuator size 2 High Flow
- Code 2E: Actuator size 2, with ECTFE union nut
- Code 2EF: Actuator size 2 High Flow, with ECTFE union nut
- Code 3: Actuator size 3
- Code 3 F: Actuator size 3 High Flow
- Code 3E: Actuator size 3, with ECTFE union nut
- Code 3EF: Actuator size 3 High Flow, with ECTFE union nut
- Code 4: Actuator size 4

2) **Position of SpaceSaver**

- Code K: Flare connection in position X, butt weld spigot in position Z
- Code S: SpaceSaver for X+ Z position
- Code Z: SpaceSaver for Z position

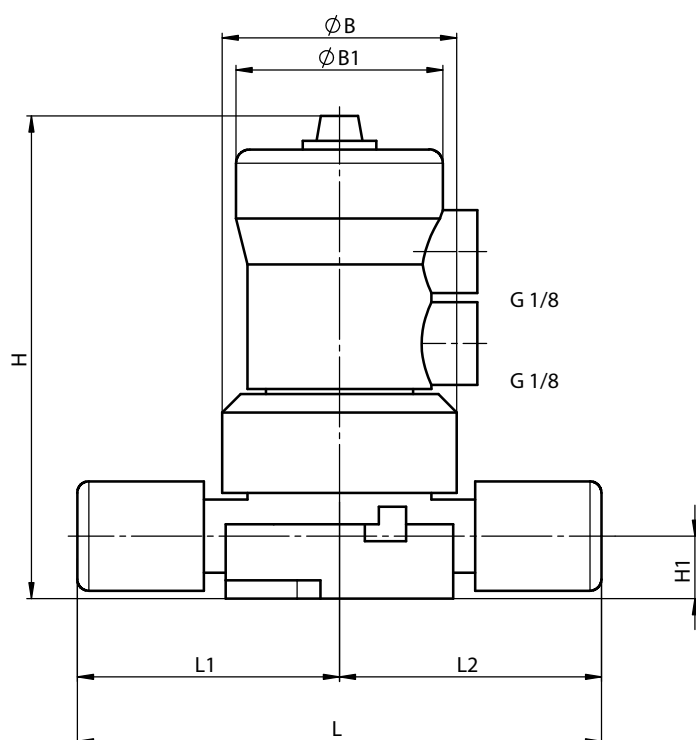
**PrimeLock® connection (code PL)**

Actuator size <sup>1)</sup>	Connection size	SpaceSaver pos. <sup>2)</sup>	ØB	ØB1	H	H1	L	L1	L2
1, 1E	1/4"	-	51.4	45.0	107.0	15.0	113.0	57.0	57.0
1, 1E	3/8"	-	51.4	45.0	107.0	15.0	117.0	59.0	59.0
2, 2E	1/2"	-	64.0	64.7	126.5	16.0	141.0	71.0	71.0
2 F, 2EF	3/4"	-	64.0	64.7	126.5	19.0	156.0	79.0	79.0
2 F, 2EF	1"	-	64.0	64.7	126.5	19.0	169.0	85.0	85.0
3 F, 3EF	1"	-	80.0	86.8	185.0	25.0	185.0	94.0	94.0
3 F, 3EF	1 1/4"	-	80.0	86.8	209.0	25.0	209.0	105.0	105.0

Dimensions in mm

**1) Actuator version**

- Code 1: Actuator size 1
- Code 1E: Actuator size 1, with ECTFE union nut
- Code 2: Actuator size 2
- Code 2 F: Actuator size 2 High Flow
- Code 2E: Actuator size 2, with ECTFE union nut
- Code 2EF: Actuator size 2 High Flow, with ECTFE union nut
- Code 3: Actuator size 3
- Code 3 F: Actuator size 3 High Flow
- Code 3E: Actuator size 3, with ECTFE union nut
- Code 3EF: Actuator size 3 High Flow, with ECTFE union nut

**2) Position of SpaceSaver**

- Code K: Flare connection in position X, butt weld spigot in position Z
- Code S: SpaceSaver for X+ Z position
- Code Z: SpaceSaver for Z position

**Tube spigot (code T3)**

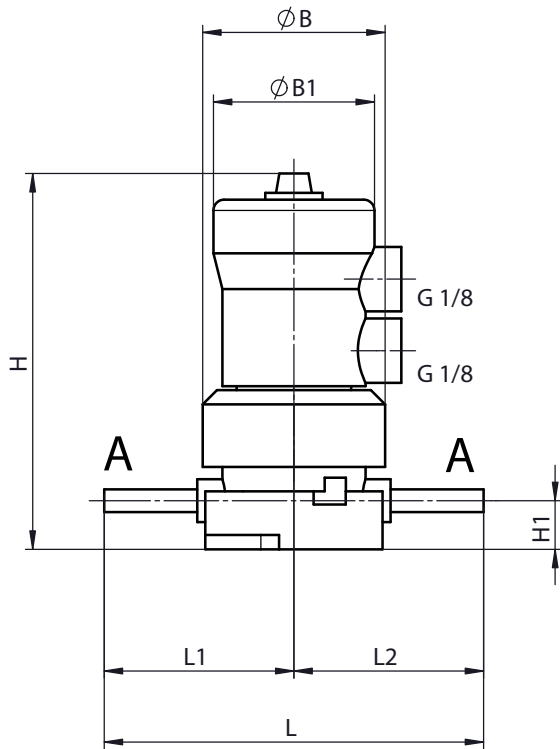

Actuator size <sup>1)</sup>	Connection size	SpaceSaver pos. <sup>2)</sup>	ØB	ØB1	H	H1	L	L1	L2	Spigot (A)	
										ød	ød1
1, 1E	3/8"	-	51.4	45.0	107.0	13.6	106.0	53.0	53.0	9.5	6.6
2, 2E	1/2"	-	64.0	64.7	120.5	16.0	122.0	61.0	61.0	12.7	9.7
2, 2E	3/4"	-	64.0	64.7	126.5	19.0	135.0	67.5	67.5	19.05	15.9
3, 3E	1"	-	80.0	86.0	166.5	25.0	165.8	82.5	82.5	25.4	22.2
2 F, 2EF	3/4"	-	64.0	64.7	126.5	19.0	135.0	67.5	67.5	19.05	15.9
2 F, 2EF	1"	-	64.0	64.7	126.5	19.0	148.0	74.0	74.0	25.4	22.2
3 F, 3EF	1"	-	80.0	86.8	166.5	25.0	165.0	82.5	82.5	25.4	22.2
3 F, 3EF	1 1/4"	-	80.0	86.8	166.5	25.0	176.0	88.0	88.0	31.75	28.2

Dimensions in mm

1) **Actuator version**

- Code 1: Actuator size 1
- Code 1E: Actuator size 1, with ECTFE union nut
- Code 2: Actuator size 2
- Code 2 F: Actuator size 2 High Flow
- Code 2E: Actuator size 2, with ECTFE union nut
- Code 2EF: Actuator size 2 High Flow, with ECTFE union nut
- Code 3: Actuator size 3
- Code 3 F: Actuator size 3 High Flow
- Code 3E: Actuator size 3, with ECTFE union nut
- Code 3EF: Actuator size 3 High Flow, with ECTFE union nut

2) **Position of SpaceSaver**

- Code K: Flare connection in position X, butt weld spigot in position Z
- Code S: SpaceSaver for X+ Z position
- Code Z: SpaceSaver for Z position

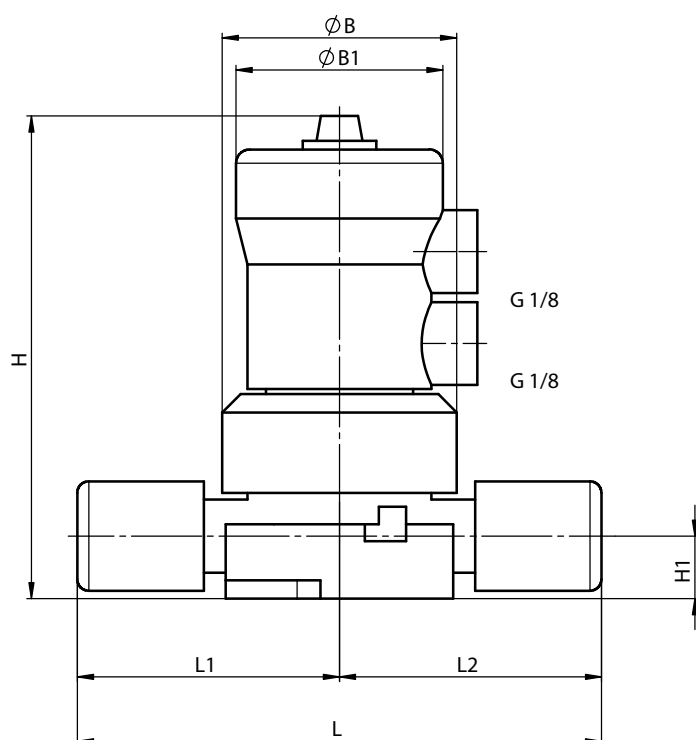
**Nexus Connect® (code NX)****Nexus Connect®, welded**

Actuator size <sup>1)</sup>	Connection size	SpaceSaver pos. <sup>2)</sup>	ØB	ØB1	H	H1	L	L1	L2
1	1/4"	-	51.4	45.0	107.0	13.6	140.5	70.3	70.3
1	3/8"	-	51.4	45.0	107.0	13.6	147.7	73.9	73.9
2	1/2"	-	64.0	64.7	126.5	19.0	153.0	76.5	76.5
2	3/4"	-	64.0	64.7	126.5	19.0	179.1	89.6	89.6
2F	3/4"	-	64.0	64.7	126.5	19.0	178.4	89.2	89.2
3	1"	-	80.0	86.8	166.5	25.0	205.0	102.5	102.5
3F	1"	-	80.0	86.8	166.5	25.0	222.4	111.2	111.2

**Nexus Connect®, SpaceSaver**

Actuator size <sup>1)</sup>	Connection size	SpaceSaver pos. <sup>2)</sup>	ØB	ØB1	H	H1	L	L1	L2
1	3/8"	S	51.4	45.0	105.0	13.6	112.4	56.2	56.2
2	1/2"	S	64.0	64.7	120.5	16.0	131.6	65.8	65.8
2F	3/4"	S	64.0	64.7	126.5	19.0	145.1	72.6	72.6
2F	1"	S	64.0	64.7	126.5	19.0	162.0	81.0	81.0
3F	1"	S	80.0	86.8	166.5	25.0	176.3	88.2	88.2

Dimensions in mm

1) **Actuator version**

- Code 1: Actuator size 1
- Code 2: Actuator size 2
- Code 2 F: Actuator size 2 High Flow
- Code 3: Actuator size 3
- Code 3 F: Actuator size 3 High Flow

2) **Position of SpaceSaver**

- Code S: SpaceSaver for X+ Z position

**T body (code T)**

**Flare connection (code 73, 75, 77)**

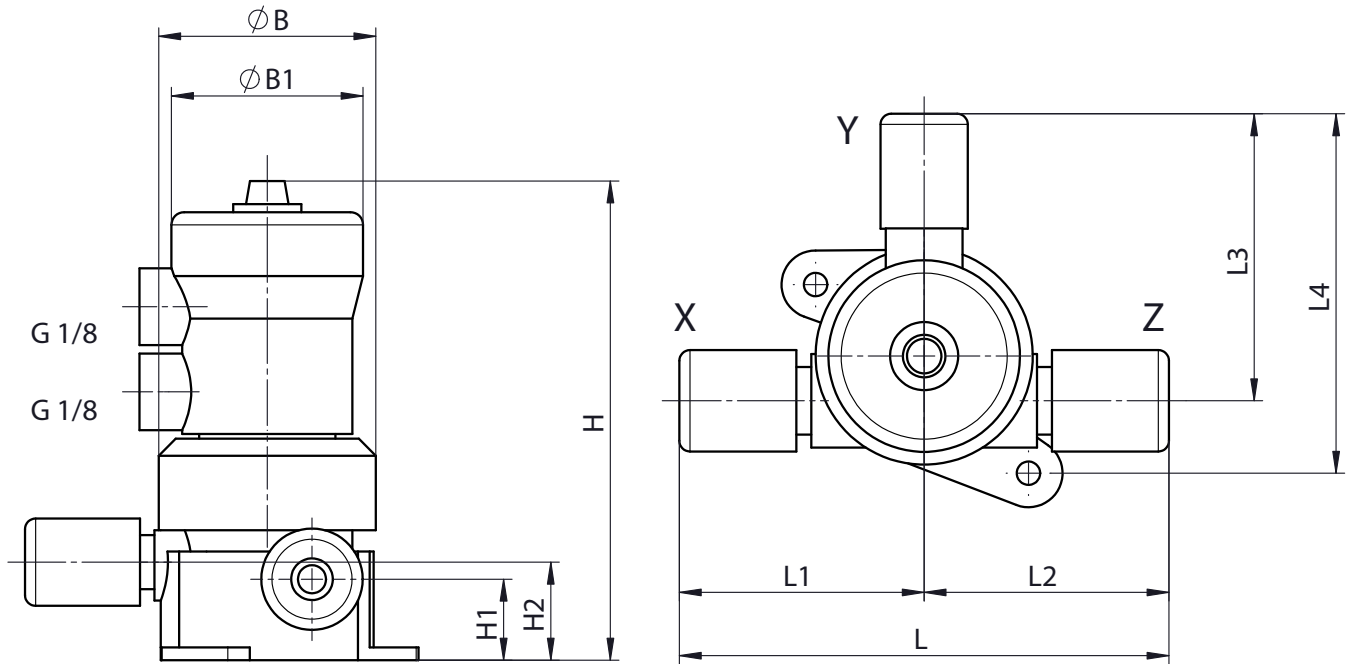

Actuator size <sup>1)</sup>	Connection size		SpaceSaver pos. <sup>2)</sup>		$\phi B$	$\phi B1$	H	H1	H2	L	L1	L2	L3	L4
	Pos. (X, Z)	Pos. (Y)	Pos. (X, Z)	Pos. (Y)										
1, 1E	3/8"	1/4"	-	-	51.4	45.0	115.0	19.0	23.0	115.0	57.5	57.5	67.4	84.4
1, 1E	3/8"	3/8"	-	-	51.4	45.0	115.0	19.0	23.0	115.0	57.5	57.5	68.0	85.0
1, 1E	1/2"	3/8"	-	-	51.4	45.0	115.0	19.0	23.0	120.8	60.4	60.4	68.0	85.0
1, 1E	1/2"	3/8"	Z	-	51.4	45.0	115.0	19.0	23.0	131.9	60.4	71.5	68.0	85.0
1, 1E	3/4"	3/8"	-	-	51.4	45.0	115.0	19.0	23.0	125.8	62.9	62.9	68.0	85.0
1, 1E	3/4"	3/8"	Z	-	51.4	45.0	115.0	19.0	23.0	135.3	62.9	72.4	68.0	85.0
2, 2E	1/2"	1/2"	-	-	64.0	64.7	126.5	19.0	19.0	131.8	65.9	65.9	80.4	98.4
2, 2E	1/2"	1/2"	Z	-	64.0	64.7	126.5	19.0	19.0	136.0	65.9	70.1	80.4	98.4
2, 2E	1/2"	1/2"	-	Y	64.0	64.7	126.5	19.0	19.0	131.8	65.9	65.9	85.5	103.5
2, 2E	3/4"	1/2"	-	-	64.0	64.7	126.5	19.0	19.0	133.8	66.9	66.9	80.4	98.4
2, 2E	3/4"	1/2"	S	-	64.0	64.7	126.5	19.0	19.0	156.8	78.4	78.4	80.4	98.4
2, 2E	3/4"	1/2"	X	-	64.0	64.7	126.5	19.0	19.0	145.3	66.9	78.4	80.4	98.4
2, 2E	3/4"	1/2"	Z	-	64.0	64.7	126.5	19.0	19.0	145.3	66.9	78.4	80.4	98.4
2, 2E	3/4"	1/2"	-	Y	64.0	64.7	126.5	19.0	19.0	133.8	66.9	66.9	85.5	103.5
2, 2E	3/4"	3/4"	-	-	64.0	64.7	126.5	19.0	19.0	133.8	66.9	66.9	81.4	99.4
2, 2E	3/4"	3/4"	X	-	64.0	64.7	126.5	19.0	19.0	145.3	78.4	66.9	81.4	99.4
2, 2E	3/4"	3/4"	Z	-	64.0	64.7	126.5	19.0	19.0	145.3	66.9	78.4	81.4	99.4
2, 2E	3/4"	3/4"	-	Y	64.0	64.7	126.5	19.0	19.0	133.8	66.9	66.9	92.4	110.4
3, 3E	1"	1"	-	-	80.0	86.8	170.0	25.0	25.0	168.0	84.0	84.0	110.5	133.0
3, 3E	1"	1"	X	-	80.0	86.8	170.0	25.0	25.0	177.9	93.9	84.0	110.5	133.0
3, 3E	1 1/4"	1/2"	-	-	80.0	86.8	170.0	25.0	25.0	238.4	119.2	119.2	99.9	122.4
3, 3E	1 1/4"	1"	-	-	80.0	86.8	170.0	25.0	25.0	238.4	119.2	119.2	110.5	133.0

Actuator size <sup>1)</sup>	Connection size		SpaceSaver pos. <sup>2)</sup>		ØB	ØB1	H	H1	H2	L	L1	L2	L3	L4
	Pos. (X, Z)	Pos. (Y)	Pos. (X, Z)	Pos. (Y)										
<b>3, 3E</b>	<b>1¼"</b>	<b>1¼"</b>	-	-	80.0	86.8	170.0	25.0	25.0	238.4	119.2	119.2	143.2	165.7

Dimensions in mm

1) **Actuator version**

- Code 1: Actuator size 1
- Code 1E: Actuator size 1, with ECTFE union nut
- Code 2: Actuator size 2
- Code 2 F: Actuator size 2 High Flow
- Code 2E: Actuator size 2, with ECTFE union nut
- Code 2EF: Actuator size 2 High Flow, with ECTFE union nut
- Code 3: Actuator size 3
- Code 3 F: Actuator size 3 High Flow
- Code 3E: Actuator size 3, with ECTFE union nut
- Code 3EF: Actuator size 3 High Flow, with ECTFE union nut

2) **Position of SpaceSaver**

- Code X: SpaceSaver for X position
- Code Y: SpaceSaver for Y position
- Code Z: SpaceSaver for Z position

**Butt weld spigot (code 30)**

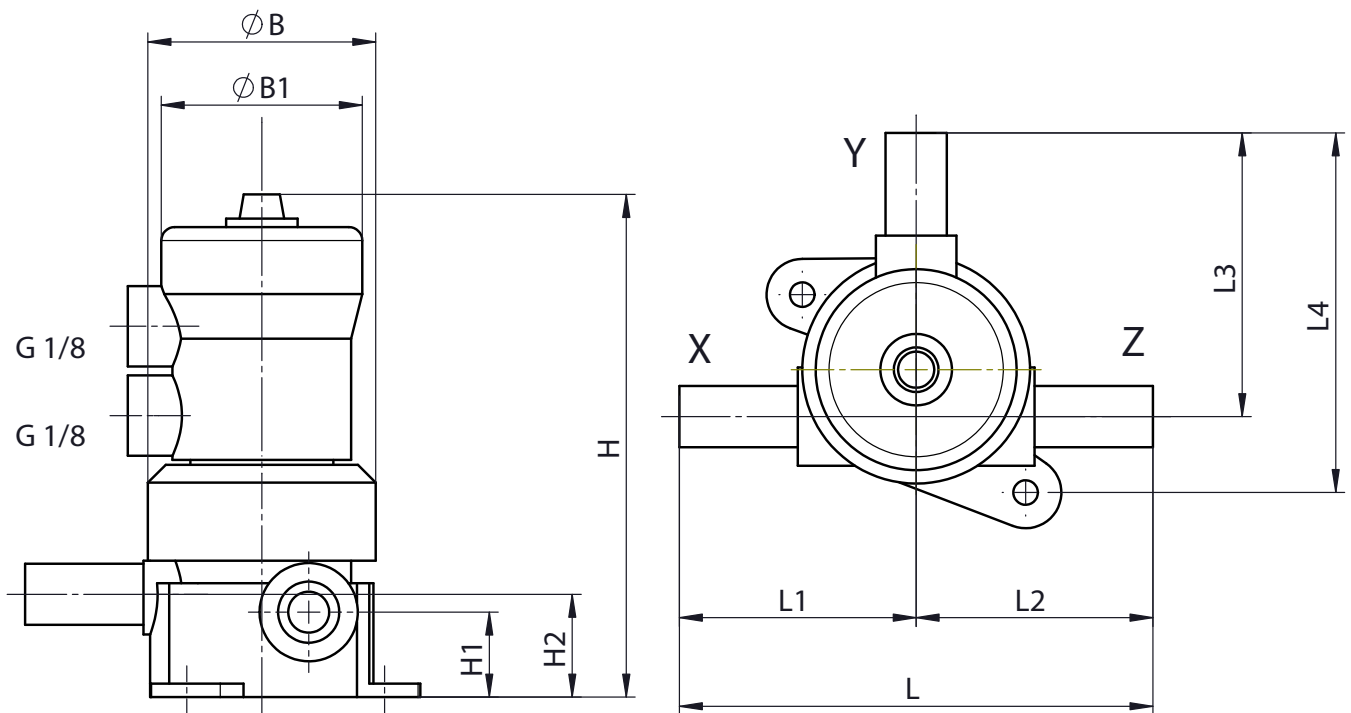

Dimensions: Spigot (A) (see "Butt weld spigot (code 30)", page 24)

Actuator size <sup>1)</sup>	Connection size		SpaceSaver pos. <sup>2)</sup>	Con- nection <sup>3)</sup>	ØB	ØB1	H	H1	H2	L	L1	L2	L3	L4
	Pos. (X, Z)	Pos. (Y)												
1, 1E	1/4"	1/4"	-	30	51.4	45.0	115.0	19.0	23.0	106.0	53.0	53.0	63.5	80.5
1, 1E	1/2"	1/4"	-	30	51.4	45.0	115.0	19.0	23.0	106.0	53.0	53.0	63.5	80.5
2, 2E	1/2"	1/2"	-	30	64.0	64.7	126.5	19.0	19.0	122.0	61.0	61.0	75.5	93.5
2, 2E	3/4"	1/4"	-	30	64.0	64.7	135.9	25.0	28.5	140.0	70.0	70.0	76.5	96.0
3, 3E	1"	1/2"	-	30	80.0	86.8	170.0	25.0	25.0	163.0	81.5	81.5	102.0	124.5
3, 3E	1"	1/2"	-	73, 75, 77	80.0	86.8	170.0	25.0	25.0	163.0	81.5	81.5	99.9	122.4
3, 3E	1"	3/4"	-	30	80.0	86.8	170.0	25.0	25.0	163.0	81.5	81.5	102.0	124.5
3, 3E	1"	1"	-	30	80.0	86.8	170.0	25.0	25.0	163.0	81.5	81.5	103.5	126.0

Actuator size <sup>1)</sup>	Connection size		SpaceSaver pos. <sup>2)</sup>	Con- nection <sup>3)</sup>	ØB	ØB1	H	H1	H2	L	L1	L2	L3	L4
	Pos. (X, Z)	Pos. (Y)	Pos. (Y)	Pos. (Y)										
<b>3, 3E</b>	<b>1"</b>	<b>1"</b>	-	<b>73, 75, 77</b>	80.0	86.8	170.0	25.0	25.0	163.0	81.5	81.5	110.5	133.0

Dimensions in mm

1) **Actuator version**

- Code 1: Actuator size 1
- Code 1E: Actuator size 1, with ECTFE union nut
- Code 2: Actuator size 2
- Code 2 F: Actuator size 2 High Flow
- Code 2E: Actuator size 2, with ECTFE union nut
- Code 2EF: Actuator size 2 High Flow, with ECTFE union nut
- Code 3: Actuator size 3
- Code 3 F: Actuator size 3 High Flow
- Code 3E: Actuator size 3, with ECTFE union nut
- Code 3EF: Actuator size 3 High Flow, with ECTFE union nut

2) **Position of SpaceSaver**

- Code X: SpaceSaver for X position
- Code Y: SpaceSaver for Y position
- Code Z: SpaceSaver for Z position

3) **Connection type**

- Code 30: Spigot – inch, for welding or solvent cementing, depending on the body material
- Code 73: Flare connection with CPFA union nut
- Code 75: Flare connection with PVDF union nut
- Code 77: Flare connection with PFA union nut

**Mounting dimensions**

2/2-way valve (code D)

T valve (code T)

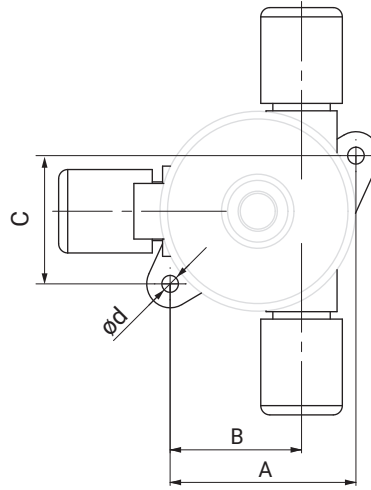
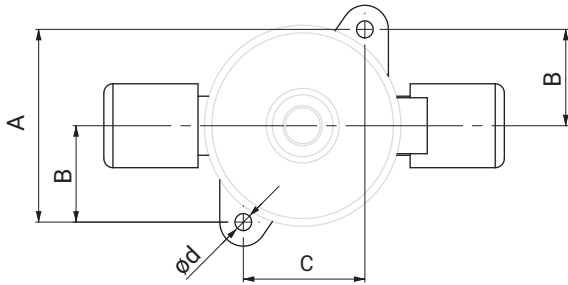

**2/2-way valves (code D)**

Actuator size	ød	A	B	C
1, 1E	5.5	50.5	25.25	33.5
2, 2E, 2 F, 2EF	5.5	61.5	31.0	40.0
3, 3E, 3 F, 3EF	6.5	78.0	39.0	56.0
4, 4E	9.0	124.0	62.0	94.0

Dimensions in mm

**T valve (code T)**

Actuator size	ød	A	B	C
1, 1E	5.5	44.3	27.3	50.0
2, 2E, 2 F, 2EF	5.5	61.5	43.5	41.5
3, 3E, 3 F, 3EF	6.5	79.5	57.0	52.5

Dimensions in mm

**Mounting holes, round and slotted hole**

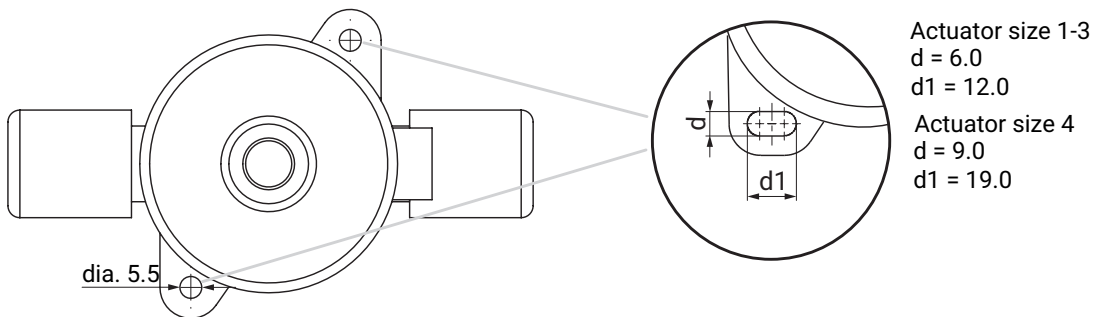

Dimensions in mm

Dear customers,

In order to simplify installation, we are switching over the mounting holes to slotted holes for all valve sizes.

Due to the gradual changeover in manufacturing, you may therefore receive valve bodies with new slotted holes and also with the old, round boreholes during this phase.

We ask for your understanding in this matter.

# **GEMÜ C60 CleanStar PFA 3/5-way**

**Pneumatically operated 3/5-way diaphragm valve with PFA valve body**



## **Features**

- High flow rate
- Minimal contamination
- Minimal deadleg
- Optional flow direction
- Can be used as a media mixing configuration or manifold valve
- Both actuators can be independently controlled
- Combination of manual and pneumatic actuator selectable

---

## **Description**

The ultra pure 3/5-way diaphragm valve GEMÜ C60 CleanStar® with a V valve body produced from PFA has two valve seats. All media wetted parts are produced from PFA or PTFE (diaphragms). The external actuator parts are produced from PVDF. Solid mounting lugs, as well as a leak detection hole, are integrated as standard. The union nuts are available in PVDF, PFA and C-PFA. This High Purity version of the CleanStar® series complies with the strictest purity standards and boasts high chemical resistance. It can also be used with high media temperatures. As such, it is often used at the supply and distribution level in semiconductor factories, particularly to collect or mix media flows.

## **Technical specifications**

- **Media temperature:** -10 to 150 °C
- **Ambient temperature:** 0 to 60 °C
- **Operating pressure:** 0 to 6 bar
- **Nominal sizes:** DN 10 to 15
- **Body configurations:** V valve body
- **Connection types:** Flare | Flare SpaceSaver
- **Connection standards:** DIN
- **Body materials:** PFA
- **Diaphragm materials:** PTFE/EPDM
- **Conformities:** EAC | FDA | TA Luft (German Clean Air Act)

Technical data depends on the respective configuration

## Availability C60 PFA 3/5-way

### Connections

Actuator size	Flare connection	SpaceSaver position					Butt weld spigot
	Connection size X, Y, Z	Without	X (code X)	Y (code Y)	Z (code Z)	X, Z (code S)	
	Code						
2	8	X	-	-	-	-	-
	12	X	-	-	-	-	-

### Actuator assignments

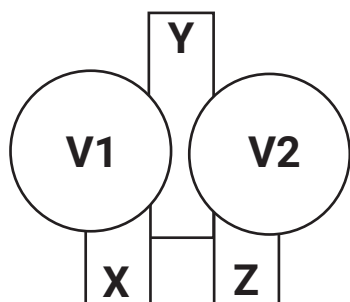

V1		V2		Control function (code)
Valve 1 (position X - Y)		Valve 2 (position Z - Y)		
Type	Control function	Type	Control function	
C60	Normally closed (NC)	C60	Normally closed (NC)	<b>1</b>
C60	Normally closed (NC)	C60	Normally open (NO)	<b>D</b>
C60	Normally closed (NC)	C67	Manually operated	<b>F</b>
C60	Normally open (NO)	C60	Normally open (NO)	<b>2</b>
C60	Normally open (NO)	C60	Normally closed (NC)	<b>G</b>
C60	Normally open (NO)	C67	Manually operated	<b>K</b>
C67	Manually operated	C60	Normally closed (NC)	<b>A</b>
C67	Manually operated	C60	Normally open (NO)	<b>B</b>
C67	Manually operated	C67	Manually operated	<b>0</b>

## Order data C60 PFA 3/5-way

### Order codes

The order data provide an overview of standard configurations.

Please check the availability before ordering. Other configurations available on request.

Provisionally only designs with the same nominal sizes in all positions

1 Type	Code
<b>C60 - valve 1 (between X - Y)</b>	
Diaphragm valve, pneumatically operated, plastic piston actuator, optical position indicator, stroke limiter (for actuator size 1–3 only)	C60
<b>C67 - valve 1 (between X - Y)</b>	
Diaphragm valve, manually operated, plastic handwheel, seal adjuster	C67

2 Position of SpaceSaver	Code
Without	
SpaceSaver for X+ Z position	S
SpaceSaver for X position	X
SpaceSaver for Y position	Y
SpaceSaver for Z position	Z

3 Connection size	Code
<b>Position Y</b>	
1/2", international code: 8	8
3/4", international code: 12	12

4 Body configuration	Code
Multi-port body V-form	V

5 Connection type	Code
<b>Tube</b>	
Flare connection with CPFA union nut	73
Flare connection with PVDF union nut	75
Flare connection with PFA union nut	77

6 Valve body material	Code
PFA, perfluoroalkoxy	30

7 Diaphragm material	Code
PTFE/EPDM one-piece	54

8 Control function	Code
<b>C60 / C60</b>	
Normally closed (NC)	1
Normally open (NO)	2
Normally closed, normally open	D
Normally open, normally closed	G

8 Control function	Code
<b>C60 / C67</b>	
Normally closed, manually operated	F
Normally open, manually operated	K
<b>C67 / C60</b>	
Manually operated, normally closed	A
Manually operated, normally open	B
<b>C67 / C67</b>	
Manually operated	0

9 Actuator version	Code
<b>Standard version</b>	
Actuator size 2	2
<b>Standard version with ECTFE union nut</b>	
Actuator size 2, with ECTFE union nut	2E

10 Design	Code
Without	
C60, spring, PFA-coated (on request)	7030

11 Position of SpaceSaver-2	Code
Without	
SpaceSaver for X+ Z position	S
SpaceSaver for X position	X
SpaceSaver for Y position	Y
SpaceSaver for Z position	Z

12 Connection size 2	Code
<b>Position X and Z</b>	
1/2", international code-2: 8	8
3/4", international code-2: 12	12

13 Connection type spigot 2	Code
<b>Position X and Z</b>	
<b>Tube</b>	
Flare connection with CPFA union nut	73
Flare connection with PVDF union nut	75
Flare connection with PFA union nut	77

14 High Purity version	Code
High purity white	HPW

**Order example**

Ordering option	Code	Description
1 Type	C60	Diaphragm valve, pneumatically operated, plastic piston actuator, optical position indicator, stroke limiter (for actuator size 1–3 only)
2 Position of SpaceSaver	Y	SpaceSaver for Y position
3 Connection size	8	1/2", international code: 8
4 Body configuration	V	Multi-port body V-form
5 Connection type	75	Flare connection with PVDF union nut
6 Valve body material	30	PFA, perfluoroalkoxy
7 Diaphragm material	54	PTFE/EPDM one-piece
8 Control function	F	Normally closed, manually operated
9 Actuator version	2	Actuator size 2
10 Design		Without
11 Position of SpaceSaver-2	S	SpaceSaver for X+ Z position
12 Connection size 2	8	1/2", international code-2: 8
13 Connection type	75	Flare connection with PVDF union nut
14 High Purity version	HPW	High purity white

## Technical data C60 PFA 3/5-way

### Medium

**Working medium:** Gaseous and liquid media (specified in the table below based on nominal size) – in particular high-purity media – which have no negative impact on the physical and chemical properties of the body and diaphragm material. Inert gases are excluded.

#### Categorisation

Max. permissible operating pressure (PS)	Permissible working media/fluids acc. to nominal size			
	Group 1 fluids (hazardous)		Group 2 fluids (other)	
	Gases (diagram 6)	Liquids (diagram 8)	Gases (diagram 7)	Liquids (diagram 9)
<b>6 bar</b>	Up to max. 1"/DN25		> 1"/DN25	

### Temperature

**Media temperature:** PFA valve body material (code 30): -10 – 150 °C  
Observe pressure/temperature diagram

**Ambient temperature:** 0 – 60 °C

**Storage temperature:** 0 – 40 °C

### Pressure

**Operating pressure:** 0 – 6 bar  
applied upstream

**Pressure/temperature diagram:**

**Valve body material: PFA, 3/5-way (code 30), actuator size 2**

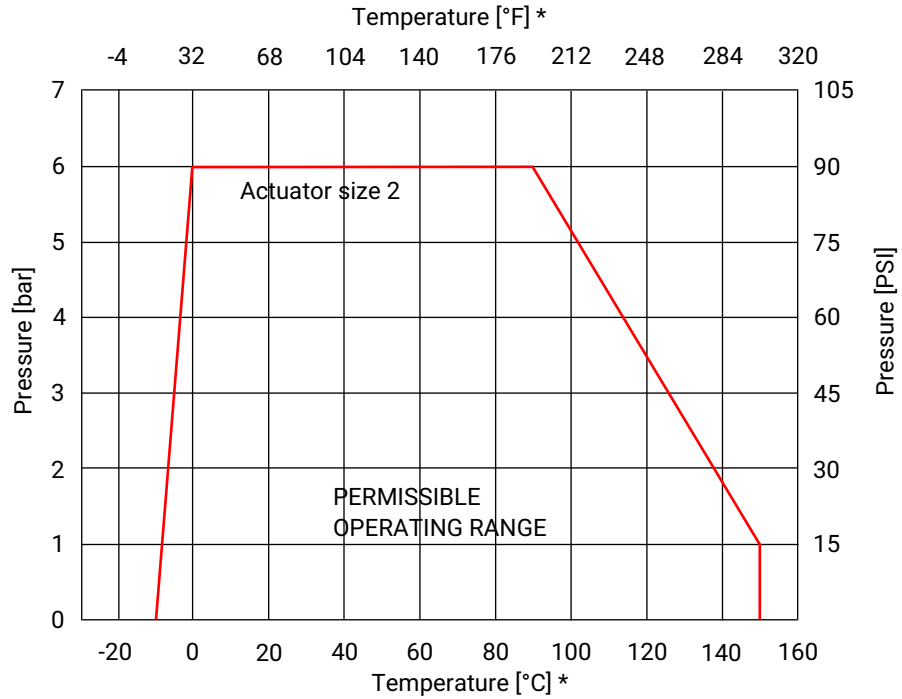

**\* Note:** The temperature/pressure diagram is only an aid. The data refers to water as a working medium. A change of operating conditions or other media may result in deviations. In case of doubt, it is advisable to test the behaviour of the material under the definitive operating conditions in a test installation. Temperatures below 0 °C can have a negative influence on the actuation speed. The pressure-bearing valve bodies are designed to maintain their functionality unchanged for a theoretical time period of 25 years. Continuously rising medium temperatures would change this time period as follows:

- 24.4 years at 110 °C
- 8.2 years at 120 °C
- 3.4 years at 130 °C
- 1.4 years at 140 °C
- 1.0 year at 150 °C

**Kv values:**

Actuator size	Body configuration	Connection size	Connection
		X, Y, Z	Tube
<b>2</b>	<b>V</b>	1/2"	28.0
		3/4"	53.0

Kv values in l/min

If the 2/2-way body has a tube and pipe connection, the Kv values of the tube connection are used.

**Vacuum:**

400 mbar absolute

The service life of the valve may be affected if exposed to a greater vacuum or when valves are installed on the pump suction side.

Pneumatic actuator

Control pressure:

Control function	Actuator size	Control pressure
1	2	4 - 7 bar
2	2	Max. 5 bar

Control pressure / operating pressure characteristics:

Control function 2 – normally open (NO)

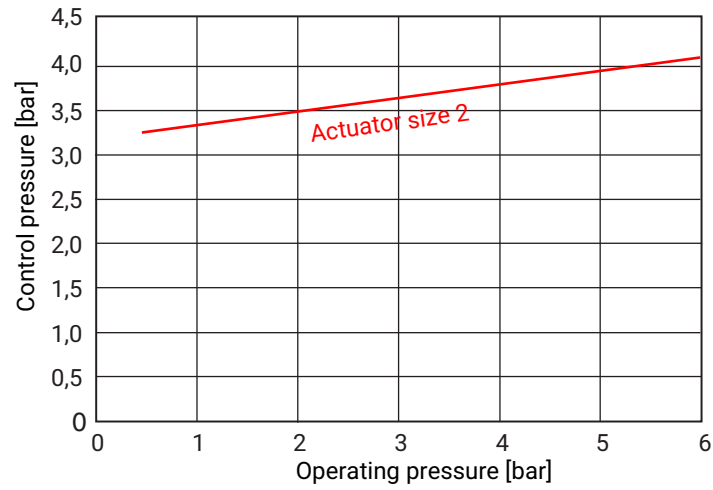

Control air connection: G 1/8

Filling volume:

Actuator size	Control function	
	Normally closed (NC)	Normally open (NO)
2	29.0	42.5

Filling volume in cm<sup>3</sup>

**Product conformities**

**Machinery Directive:** 2006/42/EC

**Food:** FDA

**EAC:** The product is certified according to EAC.

**Pressure Equipment Directive:** Categorisation in accordance with 2014/68/EU Article 4 and Annex II  
Max. category **GIP** (sound engineering practice)

**Mechanical data**

**Flow direction:** Optional

**Dimensions C60 PFA 3/5-way**

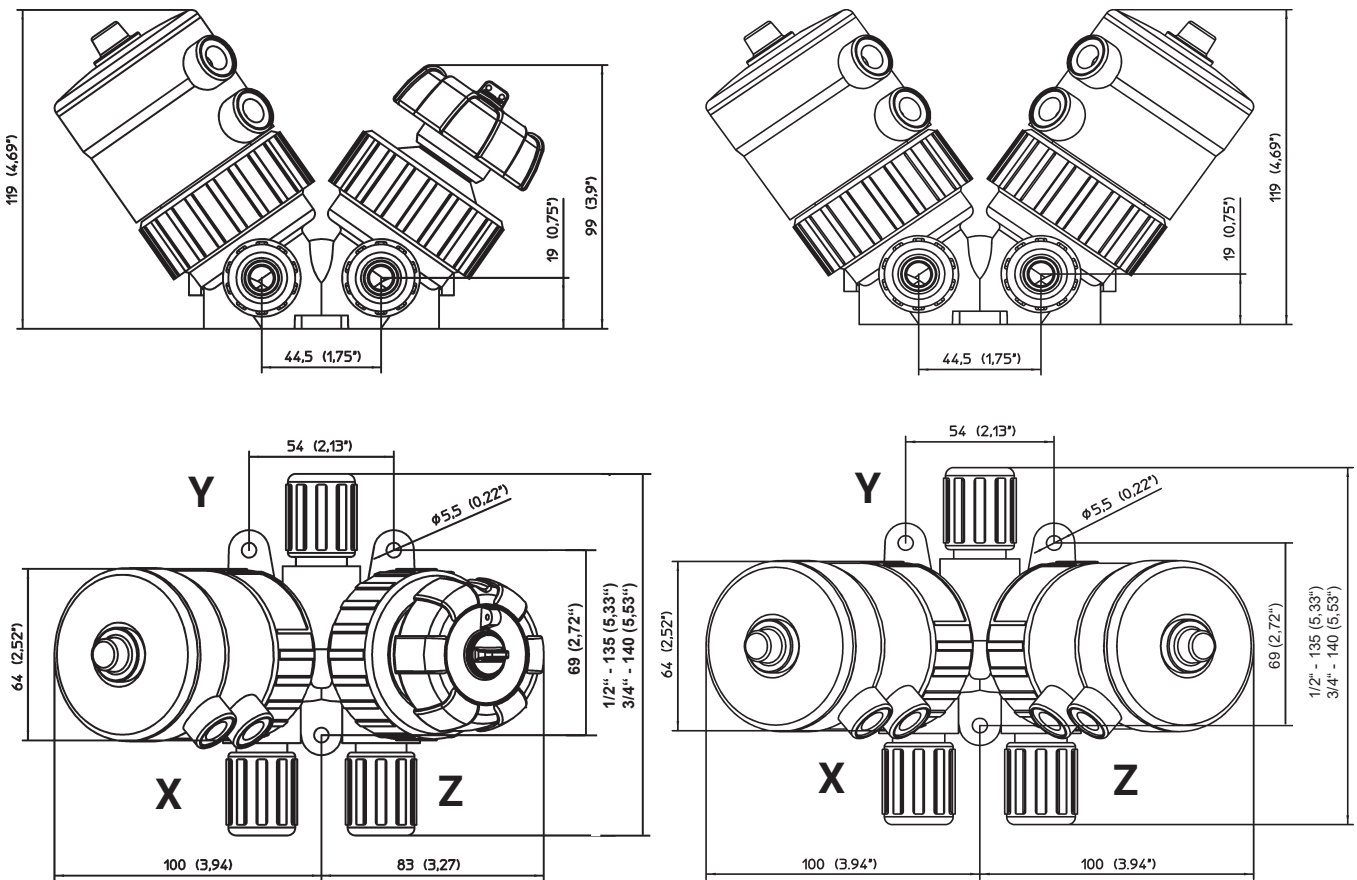

Dimensions in mm/inch

# GEMÜ C60 CleanStar PVDF

*Pneumatically operated diaphragm valve with PVDF valve body*



## Features

- Ideal for high purity media (for example ultra pure water)
- High flow rate
- Minimal deadleg
- Optional flow direction
- Manufactured in cleanroom conditions
- Union end for easy radial installation and removal reduces maintenance costs

---

## Description

The ultra pure 2/2-way diaphragm valve GEMÜ C60 CleanStar® has a plastic piston actuator and is pneumatically operated. A stroke limiter and an optical position indicator are integrated as standard. All media wetted parts are produced from PFA or PTFE. This High Purity version of the CleanStar® series complies with strict purity standards and boasts excellent chemical resistance. These valves are therefore often used in the ultra pure water industry.

## Technical specifications

- **Media temperature:** -10 to 120 °C
- **Ambient temperature:** 0 to 60 °C
- **Operating pressure:** 0 to 6 bar
- **Nominal size:** DN 15
- **Body configurations:** Straight through body
- **Connection types:** Union end
- **Connection standards:** DIN
- **Body materials:** PVDF
- **Diaphragm materials:** PTFE/EPDM
- **Conformities:** EAC | FDA | TA Luft (German Clean Air Act)

Technical data depends on the respective configuration

### **Availability of Cleanstar C60 PVDF**

Actuator size	DN	Union end (code 7, 78)	Code
<b>2</b>	<b>15</b>	<b>X</b>	<b>15</b>

## Order data C60 PVDF

### Order codes

The order data provide an overview of standard configurations.

Please check the availability before ordering. Other configurations available on request.

1 Type	Code
Diaphragm valve, pneumatically operated, plastic piston actuator, optical position indicator, stroke limiter	C60

2 DN	Code
DN 15	15

3 Body configuration	Code
2/2-way body	D

4 Connection type	Code
Union end with insert (socket) – DIN	7
Union end with insert (for IR butt welding) – DIN	78

5 Valve body material	Code
PVDF	20

6 Diaphragm material	Code
PTFE/EPDM one-piece	54

7 Control function	Code
Normally closed (NC)	1
Normally open (NO)	2

8 Actuator version	Code
Actuator size 2	2

9 High Purity version	Code
Without	
High Purity white	HPW

### Order example

Ordering option	Code	Description
1 Type	C60	Diaphragm valve, pneumatically operated, plastic piston actuator, optical position indicator, stroke limiter
2 DN	15	DN 15
3 Body configuration	D	2/2-way body
4 Connection type	78	Union end with insert (for IR butt welding) – DIN
5 Valve body material	20	PVDF
6 Diaphragm material	54	PTFE/EPDM one-piece
7 Control function	1	Normally closed (NC)
8 Actuator version	2	Actuator size 2
9 High Purity version	HPW	High Purity white

## Technical data C60 PVDF

### Medium

**Working medium:** Gaseous and liquid media (specified in the table below based on nominal size) – in particular high-purity media – which have no negative impact on the physical and chemical properties of the body and diaphragm material. Inert gases are excluded.

#### Categorisation

Max. permissible operating pressure (PS)	Permissible working media/fluids acc. to nominal size			
	Group 1 fluids (hazardous)		Group 2 fluids (other)	
	Gases (diagram 6)	Liquids (diagram 8)	Gases (diagram 7)	Liquids (diagram 9)
<b>6 bar</b>	Up to max. 1"/DN25		> 1"/DN25	

### Temperature

**Media temperature:** Valve body material PVDF (code 20): -10 – 120 °C  
Observe pressure/temperature diagram

**Ambient temperature:** 0 – 60 °C

**Storage temperature:** 0 – 40 °C

### Pressure

**Operating pressure:** 0 – 6 bar  
applied upstream

**Pressure/temperature diagram:** Valve body material: PVDF (code 20)

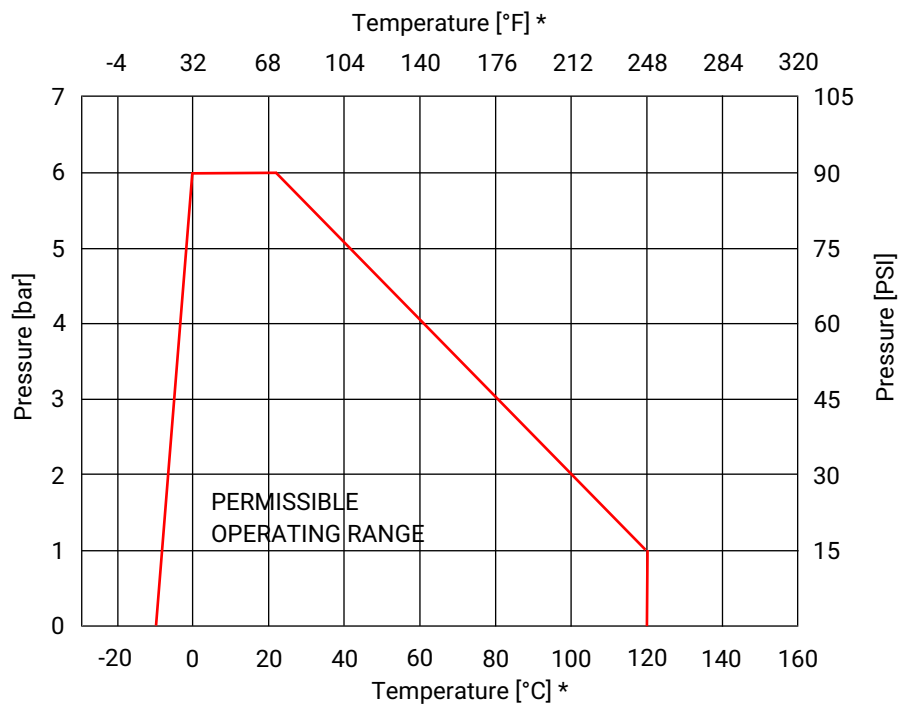

**\* Note:** The temperature/pressure diagram is only an aid. The data refers to water as a working medium. A change of operating conditions or other media may result in deviations. In case of doubt, it is advisable to test the behaviour of the material under the definitive operating conditions in a test installation. Temperatures below 0 °C can have a negative influence on the actuation speed.

**Kv values:**

Actuator size	DN	Connection size	Connection
		Pipe	Union end
<b>2</b>	<b>15</b>	1/2"	68.0

Kv values in l/min

**Vacuum:**

400 mbar absolute

The service life of the valve may be affected if exposed to a greater vacuum or when valves are installed on the pump suction side.

**Pneumatic actuator**

**Control pressure:**

Control function	Actuator size	Control pressure
1	2	4 - 7 bar
2	2	Max. 5 bar

**Control pressure / operating pressure characteristics:**

**Control function 2 – normally open (NO)**

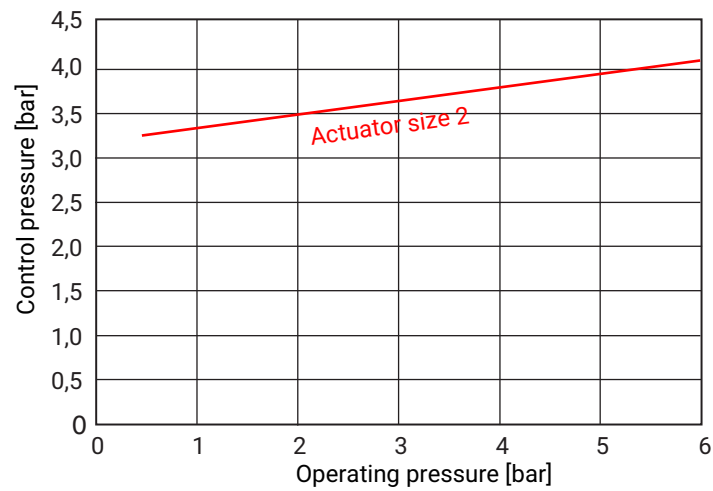

**Control air connection:** G 1/8

**Filling volume:**

Actuator size	Control function	
	Normally closed (NC)	Normally open (NO)
2	29.0	42.5

Filling volume in cm³

**Product conformities**

**Machinery Directive:** 2006/42/EC

**Food:** FDA

**EAC:** The product is certified according to EAC.

**Pressure Equipment Directive:** Categorisation in accordance with 2014/68/EU Article 4 and Annex II  
Max. category **GIP** (sound engineering practice)

**Mechanical data**

**Flow direction:** Optional

## Dimensions C60 PVDF

### Union end (code 7, 78)

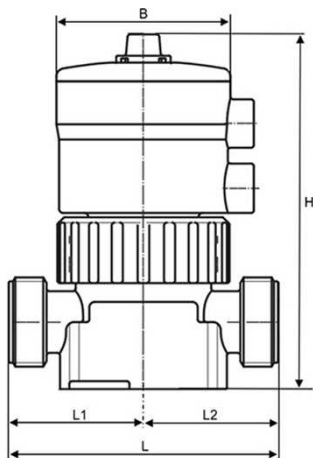

Actuator size	DN	B	H	L	L1	L2
2	15	65.0	133.0	see connection dimensions		

Dimensions in mm

### Connection dimensions

#### Union end (code 7)

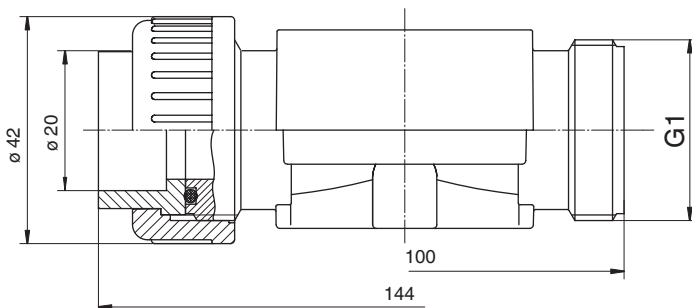

Dimensions in mm

#### Union end (code 78)

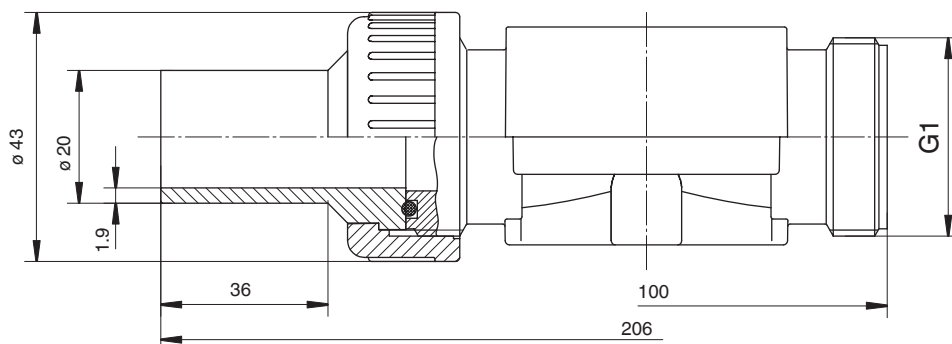

Dimensions in mm

## Mounting dimensions

2/2-way valve (code D)

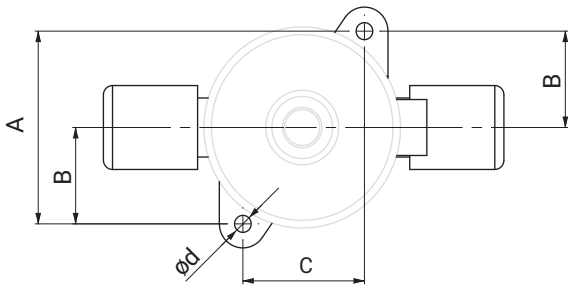

2/2-way valves (code D)

Actuator size	ød	A	B	C
2, 2E, 2 F, 2EF	5.5	61.5	31.0	40.0

Dimensions in mm

## Mounting holes, round and slotted hole

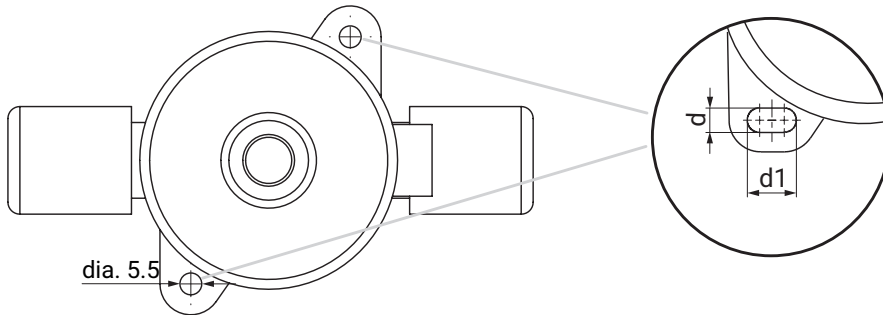

Actuator size 1-3  
d = 6.0  
d1 = 12.0

Dimensions in mm

Dear customers,

In order to simplify installation, we are switching over the mounting holes to slotted holes for all valve sizes.

Due to the gradual changeover in manufacturing, you may therefore receive valve bodies with new slotted holes and also with the old, round boreholes during this phase.

We ask for your understanding in this matter.

# GEMÜ C60 CleanStar SmartLine

SmartLine pneumatically operated diaphragm valve with PP body



## Features

- Improved flow capability over PFA versions
- Affordable CleanStar type for applications with less strict requirements in terms of purity
- PTFE diaphragm
- Valve body made of PP-R natural
- Manufactured in a monitored atmosphere

---

## Description

This GEMÜ C60 CleanStar® 2/2-way diaphragm valve has a valve body made of PP and is therefore an affordable alternative to the ultra pure designs. It has been specifically developed for industrial applications with less strict purity requirements (for example solar energy industry). All media wetted parts are made of PP or PTFE (diaphragm). The exterior actuator parts are produced from PVDF. A stroke limiter and an optical position indicator are integrated as standard. A leakage sensor connection is provided.

## Technical specifications

- **Media temperature:** -10 to 80 °C
- **Ambient temperature:** 0 to 60 °C
- **Operating pressure:** 0 to 6 bar
- **Nominal sizes:** DN 10 to 32
- **Body configurations:** Straight through body
- **Connection types:** Butt weld spigot | Flare | Union end
- **Connection standards:** DIN
- **Body materials:** PP-R, natural
- **Diaphragm materials:** PTFE/EPDM
- **Conformities:** EAC | FDA | TA Luft (German Clean Air Act)

Technical data depends on the respective configuration

**Availability C60 SmartLine**

Actuator size	DN	Flare connection	Butt weld spigot		Union end	Code
			Connection size X, Z	Connection size Z		
<b>2</b>	<b>10</b>	1/2" - 1/2"	-	On request	-	<b>8</b>
	<b>15</b>	-	15 - 15	On request	-	<b>15</b>
	<b>15</b>	3/4" - 3/4"	-	On request	-	<b>12</b>
	<b>20</b>	-	20 - 20	On request	-	<b>20</b>
	<b>20</b>	1" - 1"	-	On request	-	<b>16</b>
	<b>25</b>	-	25 - 25	On request	-	<b>25</b>
<b>3</b>	<b>20</b>	-	20 - 20	On request	-	<b>20</b>
	<b>25</b>	1" - 1"	-	On request	-	<b>16</b>
	<b>25</b>	-	25 - 25	On request	-	<b>25</b>
	<b>25</b>	-	-	On request	25 - 25	<b>25</b>
	<b>25</b>	1 1/4" - 1 1/4"	-	On request	-	<b>20</b>
	<b>32</b>	-	32 - 32	On request	-	<b>32</b>

## Order data C60 SmartLine

### Order codes

The order data provide an overview of standard configurations.

Please check the availability before ordering. Other configurations available on request.

1 Type	Code
Diaphragm valve, pneumatically operated, plastic piston actuator, optical position indicator, stroke limiter (for actuator size 1–3 only)	C60

2 Connection size	Code
1/2", international code: 8	8
DN 15	15
3/4", international code: 12	12
DN 20	20
1", international code: 16	16
DN 25	25
1 1/4", international code: 20	20
DN 32	32

3 Body configuration	Code
2/2-way body	D

4 Connection type	Code
Spigot for IR butt welding	20

4 Connection type	Code
Flare connection with PVDF union nut	75
Flare connection with PFA union nut	77
Union end with DIN insert (for IR butt welding)	78

5 Valve body material	Code
PP-R, natural	R5

6 Diaphragm material	Code
PTFE/EPDM one-piece	54

7 Control function	Code
Normally closed (NC)	1
Normally open (NO)	2

8 Actuator version	Code
Actuator size 2	2
Actuator size 3	3

9 High Purity version	Code
Without	
Smart Line	HPS

### Order example

Ordering option	Code	Description
1 Type	C60	Diaphragm valve, pneumatically operated, plastic piston actuator, optical position indicator, stroke limiter (for actuator size 1–3 only)
2 Connection size	8	1/2", international code: 8
3 Body configuration	D	2/2-way body
4 Connection type	78	Union end with DIN insert (for IR butt welding)
5 Valve body material	R5	PP-R, natural
6 Diaphragm material	54	PTFE/EPDM one-piece
7 Control function	1	Normally closed (NC)
8 Actuator version	2	Actuator size 2
9 High Purity version	HPS	Smart Line

## Technical data C60 SmartLine

### Medium

**Working medium:** Gaseous and liquid media (specified in the table below based on nominal size) – in particular high-purity media – which have no negative impact on the physical and chemical properties of the body and diaphragm material. Inert gases are excluded.

#### Categorisation

Max. permissible operating pressure (PS)	Permissible working media/fluids acc. to nominal size			
	Group 1 fluids (hazardous)		Group 2 fluids (other)	
	Gases (diagram 6)	Liquids (diagram 8)	Gases (diagram 7)	Liquids (diagram 9)
<b>6 bar</b>	Up to max. 1"/DN25		> 1"/DN25	

### Temperature

**Media temperature:** Valve body material: PP-R, natural (code R5): -10 – 80 °C  
Observe pressure/temperature diagram

**Ambient temperature:** 0 – 60 °C

**Storage temperature:** 0 – 40 °C

### Pressure

**Operating pressure:** 0 – 6 bar  
applied upstream

**Pressure/temperature diagram:** Valve body material: SmartLine (code R5)

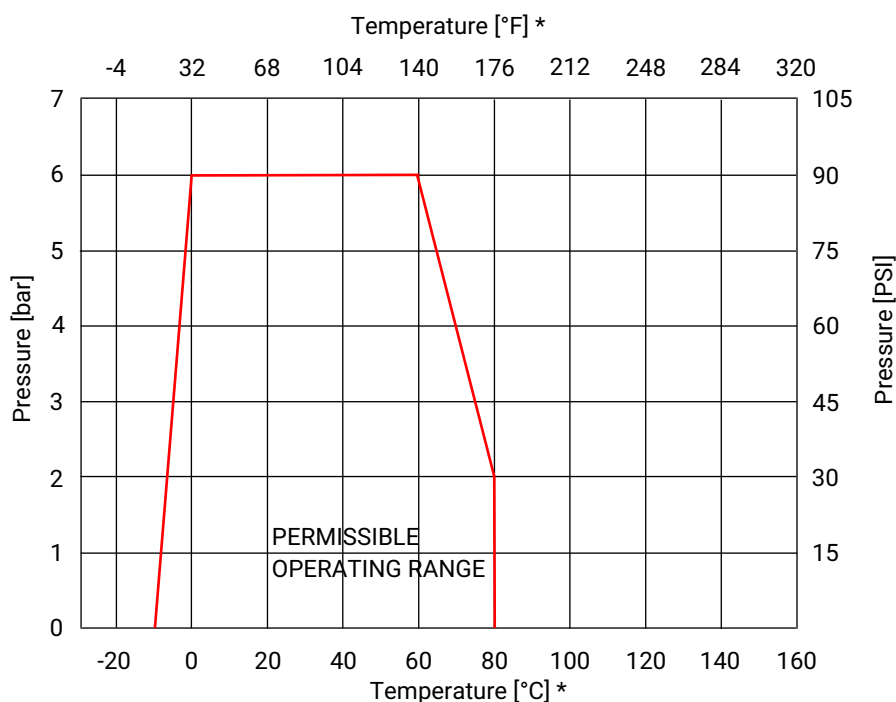

**\* Note:** The temperature/pressure diagram is only an aid. The data refers to water as a working medium. A change of operating conditions or other media may result in deviations. In case of doubt, it is advisable to test the behaviour of the material under the definitive operating conditions in a test installation. Temperatures below 0 °C can have a negative influence on the actuation speed.

**Kv values:**

Actuator size	Connection size	DN	Connection type	Connection	
				Code	Tube
2	1/2"	10	75, 77	34.2	-
		15	20	-	82.5
	3/4"	15	75	86.7	-
		20	20	-	83.7
		20	20	-	171.7
3	1"	20	75, 77	93.3	-
		25	20	-	94.0
		20	75, 77	183.3	-
		25	20	-	233.3
		25	78	-	233.3
	1 1/4"	25	75, 77	238.3	-
		32	20	-	238.3

Kv values in l/min

**Vacuum:**

400 mbar absolute

The service life of the valve may be affected if exposed to a greater vacuum or when valves are installed on the pump suction side.

**Pneumatic actuator**

**Control pressure:**

Control function	Actuator size	Control pressure
1	2	4 - 7 bar
	3	4.5-7 bar
2	2, 3	Max. 5 bar

**Control pressure / operating pressure characteristics:**

**Control function 2 – normally open (NO)**

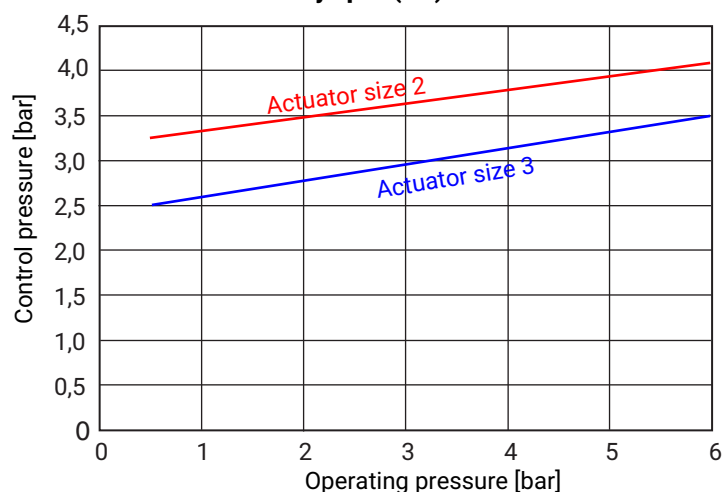

**Control air connection:**

G 1/8

**Filling volume:**

Actuator size	Control function	
	Normally closed (NC)	Normally open (NO)
2	29.0	42.5
3	63.0	95.0

Filling volume in cm³

## ***Product conformities***

**Machinery Directive:** 2006/42/EC

**Food:** FDA

**EAC:** The product is certified according to EAC.

**Pressure Equipment Directive:** Categorisation in accordance with 2014/68/EU Article 4 and Annex II  
Max. category **GIP** (sound engineering practice)

## ***Mechanical data***

**Flow direction:** Optional

## Dimensions C60 SmartLine

### Flare connection (code 75, 77)

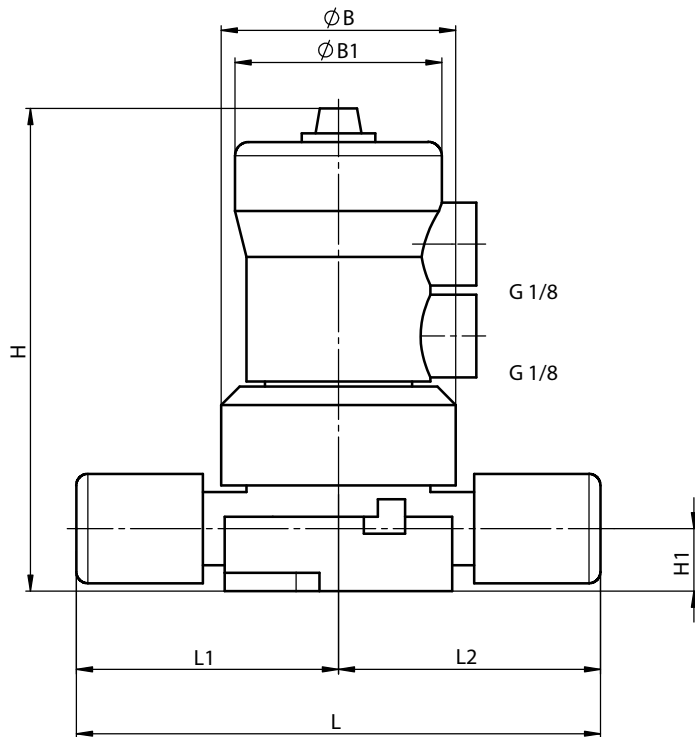

Actuator size	Connection size	ØB	ØB1	H	H1	L	L1	L2
2	1/2"	64.0	64.7	120.5	16.0	131.8	65.9	65.9
	3/4"	64.0	64.7	133.5	19.0	133.8	66.9	66.9
	1"	64.0	64.7	133.5	25.0	160.0	80.0	80.0
3	1"	80.0	86.0	162.5	25.0	180.0	90.0	90.0
	1 1/4"	80.0	86.0	162.5	25.0	192.0	96.0	96.0

Dimensions in mm

**Butt weld spigot (code 20)**

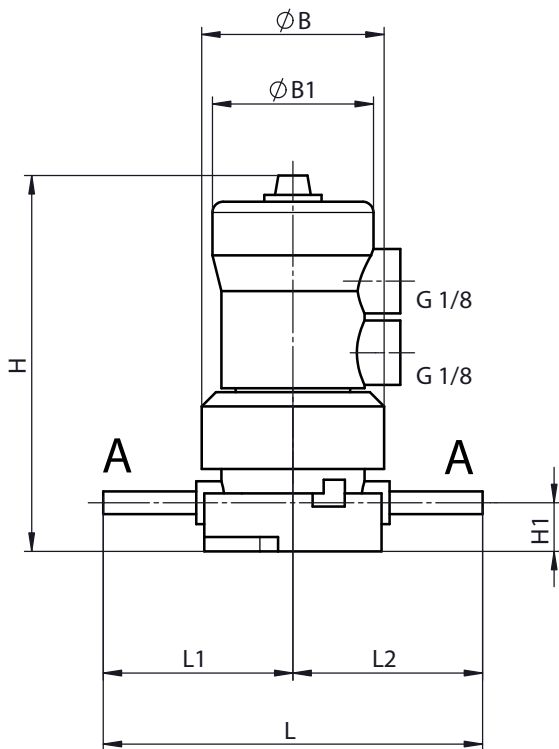

Actuator size	Conne- tion size DN	ØB	ØB1	H	H1	L	L1	L2	Spigot (A)	
									ød	ød1
2	15	64.0	64.7	133.5	19.0	131.0	65.5	65.5	20.0	16.2
	20	64.0	64.7	133.5	19.0	131.0	65.5	65.5	25.0	20.4
	25	64.0	64.7	133.5	19.0	145.0	72.5	72.5	32.0	26.0
3	20	80.0	86.0	162.5	25.0	166.0	83.0	83.0	25.0	20.4
	25	80.0	86.0	162.5	25.0	166.0	83.0	83.0	32.0	26.0
	32	80.0	86.0	162.5	25.0	172.0	86.0	86.0	40.0	32.6

Dimensions in mm

**Union end (code 78)**

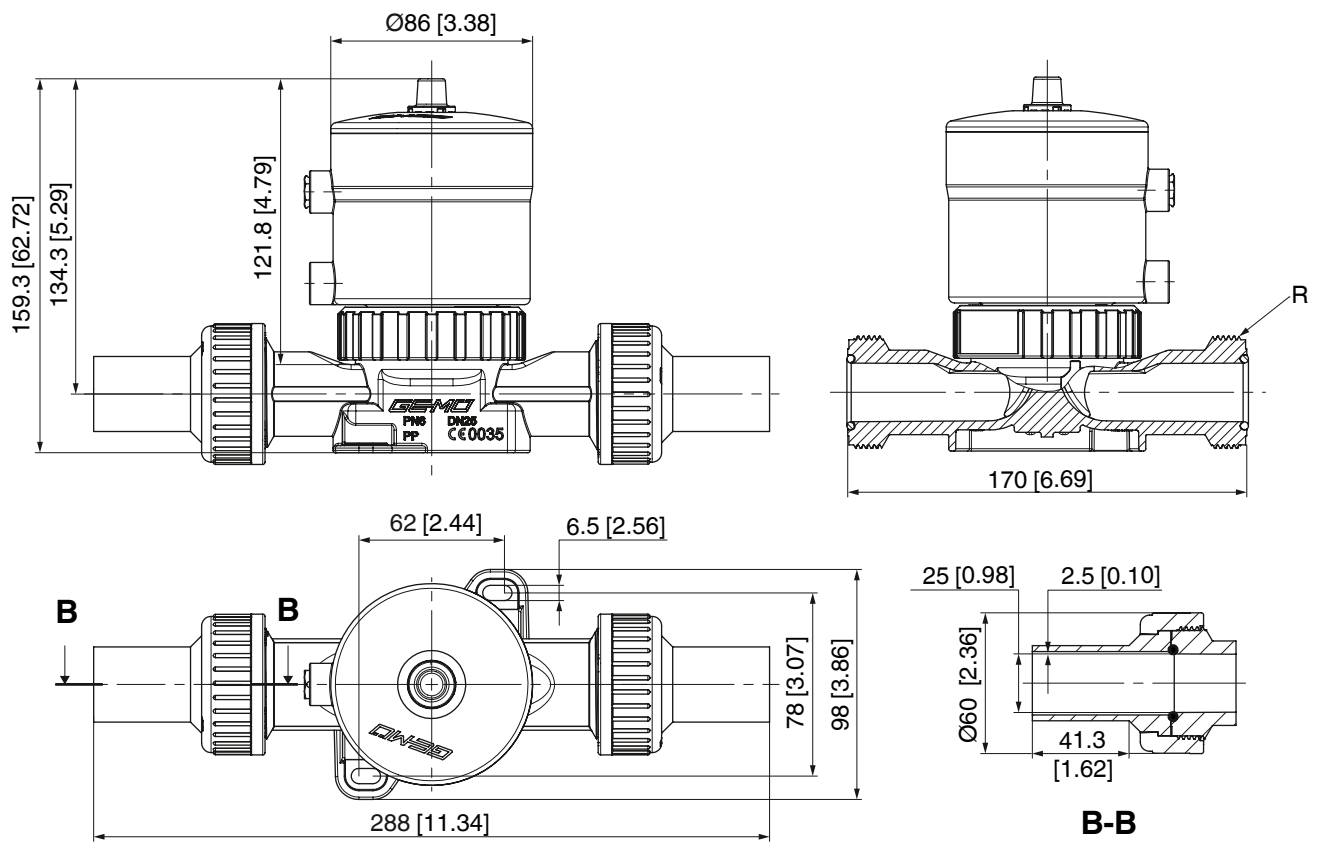

Dimensions in mm/inch

## Mounting dimensions

2/2-way valve (code D)

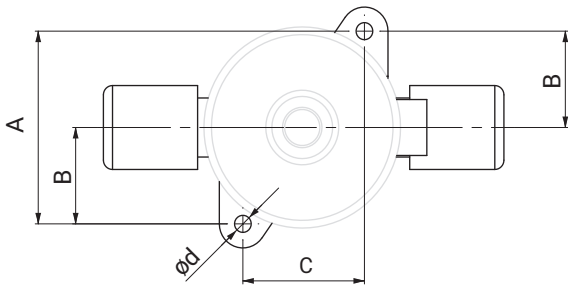

2/2-way valves (code D)

Actuator size	ød	A	B	C
2, 2E, 2 F, 2EF	5.5	61.5	31.0	40.0
3, 3E, 3 F, 3EF	6.5	78.0	39.0	56.0

Dimensions in mm

## Mounting holes, round and slotted hole

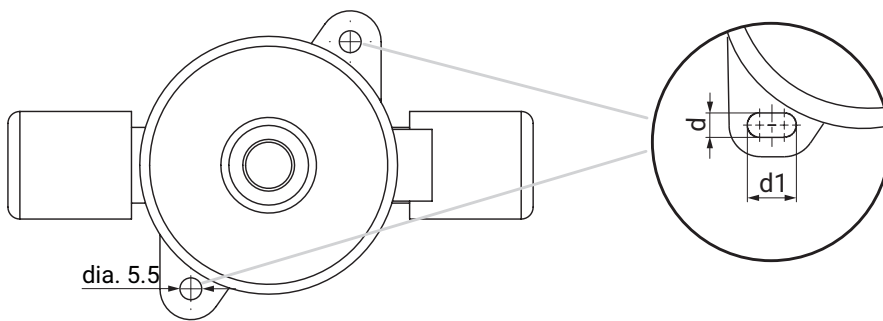

Actuator size 1-3  
 d = 6.0  
 d1 = 12.0

Dimensions in mm

Dear customers,

In order to simplify installation, we are switching over the mounting holes to slotted holes for all valve sizes.

Due to the gradual changeover in manufacturing, you may therefore receive valve bodies with new slotted holes and also with the old, round boreholes during this phase.

We ask for your understanding in this matter.

## Accessories



### GEMÜ CFSTF

#### Service tool for flare union nuts

The GEMÜ CFSTF service tool is used for the assembly of GEMÜ CF flare union nuts in PFA, PVDF and carbon fibre reinforced PFA. A precisely defined torque can be achieved when using it in combination with a torque wrench.



### GEMÜ 1098

#### Flaring mandrel

The GEMÜ 1098 flaring mandrel is an assembly tool for flare connections.



### GEMÜ FlareStar

#### PFA fittings

Over 1,000 different types of fitting are produced under cleanroom conditions in compliance with DIN 16901-140. The fitting bodies are made of PFA, while the union nuts are made of PFA, PVDF or CPFA. We can also supply all standard market connections.



### GEMÜ TU

#### PFA tubing

The GEMÜ TU product range comprises ultra pure and standard PFA tubing, which is the preferred option for applications with high-purity media and other chemicals.



### GEMÜ C67 STA

#### Service tool for actuators

Service tool for installation and removal of the central union nut.



GEMÜ Gebr. Müller Apparatebau GmbH & Co. KG  
Gert-Müller-Platz 1, 74635 Kupferzell, Germany  
Phone +49 (0) 7940 1230 · info@gemu.de  
www.gemu-group.com