

## GEMÜ 1434 $\mu$ Pos

### Intelligent electro-pneumatic positioner



#### Features

- No air consumption when idle
- Simple mounting to various actuators
- Simple commissioning due to automatic initialization
- Speed<sup>AP</sup> function for fast mounting and initialization
- Easy operation due to balanced preconfiguration
- Compact design

#### Description

The GEMÜ 1434  $\mu$ Pos digital electro-pneumatic positioner is used to control pneumatically operated small to medium nominal size process valves with single acting linear actuators. The solid compact housing has a transparent cover. LEDs for status indication are integrated. Due to factory preconfiguration, this product does not require a display with operating keys. Pneumatic and electrical connections arranged so as to save space and enable easy access. All these features make the GEMÜ 1434  $\mu$ Pos a cost-effective solution for control tasks with basic requirements.

#### Technical specifications

- **Ambient temperature:** 0 to 60 °C
- **Operating pressure :** 0 to 10 bar
- **Mode of action:** Single acting
- **Flow rate:** 15 NI/min
- **Measuring range:** Max. 30 mm, linear
- **Supply voltage:** 24 V DC
- **Electrical connection types:** M12 connector
- **Conformity:** EAC

Technical data depends on the respective configuration



## Product line



**GEMÜ 1434**  
μPos



**GEMÜ 1436 eco**  
cPos



**GEMÜ 1435**  
ePos



**GEMÜ 1436**  
cPos



**GEMÜ 1441**  
cPos-X

<b>Controller type</b>					
Positioner	●	●	●	-	●
Positioners and process controllers	-	-	-	●	-
<b>Ambient temperature</b>	0 Up to 60 °C	0 Up to 60 °C	-20 Up to 60 °C	0 Up to 60 °C	-10 Up to 60 °C
<b>Supply voltage</b>					
24 V DC	●	●	●	●	-
Via set value signal	-	-	-	-	●
<b>Flow rate</b>	15 NI/min	100 NI/min 84 NI/min	50 NI/min 90 NI/min	100 NI/min 172 NI/min 84 NI/min	115 NI/min
<b>Measuring range</b>					
Max. 30 mm, linear	●	●	●	●	-
Max. 50 mm, linear	-	●	●	●	-
Max. 75 mm, linear	-	●	●	●	●
Max. 90°, radial	-	●	●	●	●
<b>Electrical connection type</b>					
M12 cable gland	-	-	●	-	-
M12 connector	●	●	●	●	-
M16 cable gland	-	-	-	-	●
M12 plug	-	-	-	-	●
<b>Programmable outputs</b>					
No	●	●	-	-	-
Yes	-	-	●	●	●
<b>Input option</b>					
No	●	●	-	-	●
Yes	-	-	●	●	-
<b>Conformity</b>					
ATEX	-	-	-	-	●
EAC	●	●	●	●	-
FCC	-	-	-	-	●
HART	-	-	-	-	●
IECEX	-	-	-	-	●
UL listed	-	●	-	-	●
UL Recognized	-	-	-	-	●

## Product description



Item	Name	Materials
1	Housing cover	Polypropylene (UV-stabilised)
2	Housing base	Anodized aluminium or stainless steel
3	Electrical connection	Threaded piece: Stainless steel (1.4305), insert: PA
4	Adapter piece	Stainless steel (1.4305)
5	Mounting kit, valve specific	Materials, parts valve specific
	Seals	EPDM and NBR

## Status LEDs

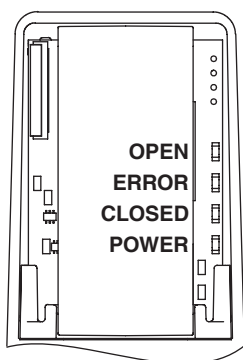

LED	Colour	Function
<b>OPEN</b>	Yellow	Process valve is opening/in OPEN position
<b>ERROR</b>	Red	Error
<b>CLOSED</b>	Orange	Process valve is closing/in CLOSED position
<b>POWER</b>	Yellow	Power

The function of the LED can differ in the case of an active ERROR LED (see operating instructions).

## GEMÜ CONEXO

The interaction of valve components that are equipped with RFID chips and an associated IT infrastructure actively increase process reliability.



Thanks to serialization, every valve and every relevant valve component such as the body, actuator or diaphragm, and even automation components, can be clearly traced and read using the CONEXO pen RFID reader. The CONEXO app, which can be installed on mobile devices, not only facilitates and improves the "installation qualification" process, but also makes the maintenance process much more transparent and easier to document. The app actively guides the maintenance technician through the maintenance schedule and directly provides him with all the information assigned to the valve, such as test reports, testing documentation and maintenance histories. The CONEXO portal acts as a central element, helping to collect, manage and process all data.

**For further information on GEMÜ CONEXO please visit:**

[www.gemu-group.com/conexo](http://www.gemu-group.com/conexo)

### Ordering

GEMÜ Conexo must be ordered separately with the ordering option "CONEXO".

### Installing the RFID chip

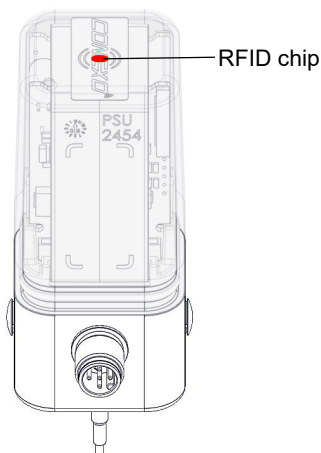

## Order data

The order data provide an overview of standard configurations.

Please check the availability before ordering. Other configurations available on request.

Note: Pneumatic connecting components (union and compressed air tube) for the connection between the process valve and positioner are included with each positioner with a pneumatic connection (7) code 2 and 3.

Note: A valve specific mounting kit is required for assembly. For designing the mounting kit, the valve type, nominal size, control function and actuator size must be stated.

## Order codes

1 Type	Code
Electro-pneumatic positioner μPos	1434

2 Fieldbus	Code
Without (3-wire version)	000

3 Accessory	Code
Accessory	Z

4 Action	Code
Single acting	1

5 Set value input	Code
4–20 mA, set value specification	A
0–20 mA, set value specification	B
0–10 V, set value specification	C

6 Housing material	Code
Stainless steel base	07
Aluminium base anodized	14

7 Pneumatic connection	Code
Air supply M5 connection thread, outlet M5 connection thread	1
Air supply via push-in connector, angle, for 4 mm tube, outlet via push-in connector, angle, for 4 mm tube	2
Air supply via push-in connector, angle, for 6 mm tube, outlet via push-in connector, angle, for 6 mm tube	3
Air supply via push-in connector, angle, for 1/4" mm tube, outlet via push-in connector, angle, for 1/4" mm tube	U

8 Option	Code
Without	00
4–20 mA, actual value output	A0
0–20 mA, actual value output	B0
0–10 V, actual value output	C0

9 Flow rate	Code
15 l/min	01

10 Travel sensor version	Code
Potentiometer, 10 mm length	010
Potentiometer, 30 mm length	030
Remote potentiometer, M12 connector	S01

11 Type of design	Code
Standard	
Dead zone presetting 2%	2442
Dead zone presetting 5%	2443
Inversed direction, for quarter turn valves control function NO (2)	6960

12 CONEXO	Code
Without	
Integrated RFID chip for electronic identification and traceability	C

**Order example**

Ordering option	Code	Description
1 Type	1434	Electro-pneumatic positioner μPos
2 Fieldbus	000	Without (3-wire version)
3 Accessory	Z	Accessory
4 Action	1	Single acting
5 Set value input	A	4–20 mA, set value specification
6 Housing material	14	Aluminium base anodized
7 Pneumatic connection	3	Air supply via push-in connector, angle, for 6 mm tube, outlet via push-in connector, angle, for 6 mm tube
8 Option	00	Without
9 Flow rate	01	15 l/min
10 Travel sensor version	010	Potentiometer, 10 mm length
11 Type of design		Without
12 CONEXO		Without

## Technical data

### Medium

<b>Working medium:</b>	Compressed air and inert gases
<b>Dust content:</b>	Class 3, max. particle size 5 µm, max. particle density 5 mg/m <sup>3</sup>
<b>Pressure dew point:</b>	Class 3, max. pressure dew point -20 °C or a minimum of 10 °C below the ambient temperature
<b>Oil content:</b>	Class 3, max. oil concentration 1 mg/m <sup>3</sup> Quality classes to DIN ISO 8573-1

### Temperature

**Storage temperature:** -10 – 60 °C

### Pressure

**Operating pressure:** 0 to 10 bar (max. 40 °C)  
0 to 8 bar (max. 60 °C)  
The applied pressure must not exceed the maximum control pressure of the process valve.

**Flow rate:** 15 NI/min

**Air consumption:** 0 NI/min (when idle)

### Product compliance

<b>EMC Directive:</b>	2014/30/EU
	Technical standards used:
<b>Interference emission:</b>	DIN EN 61000-6-4 (Sep. 2011) Interference emission class: Class A Interference emission group: Group 1
<b>Interference resistance:</b>	DIN EN 61000-6-2 (March 2006)

### Mechanical data

<b>Installation position:</b>	Optional
<b>Protection class:</b>	IP 65 acc. to EN 60529 IP 67 in accordance with EN 60529, achieved with piped air outlet. Replace with M5 adapters for connection 3 and E threaded plug connectors (1434 000 Z2, 2 pieces required) for this purpose.
<b>Weight:</b>	220 g
<b>Travel sensor:</b>	Integrated for direct mounting

	Travel sensor version	
	Code 010	Code 030
<b>Detection range:</b>	0–10 mm	0–30 mm
<b>Operating range:</b>	0–10 mm	0–30 mm
<b>Resistance:</b>	1 kΩ	3 kΩ
<b>Minimum travel sensor change:</b>	3% (only relevant for initialization)	
<b>Correlation - Travel sensor<sup>1)</sup> spindle/valve position</b>	Retracted (top) ± 100% (valve open) Extended (bottom) ± 0% (valve closed)	

1) Type of design code 6960: Inversed mode of action compared with description (Travel sensor signal inversed). For valves with inverted correlation.

## **Electrical data**

### **Power supply**

<b>Supply voltage:</b>	24 V DC (-5/+10%)
<b>Power consumption:</b>	≤ 4 W
<b>Reverse polarity protection:</b>	yes
<b>Duty cycle:</b>	Continuous duty
<b>Electrical protection class:</b>	III
<b>Electrical connection type:</b>	X1: Connector (A-coded), 1 x 5-pin M12 X3*: Plug (A-coded), 1 x 5-pin M12 * Only for travel sensor version with remote potentiometer (code S01).

### **Analogue input**

<b>Set value input:</b>	4–20 mA (code A) 0–20 mA (code B) 0–10 V (code C)
<b>Input type:</b>	passive
<b>Input load:</b>	0/4–20 mA: 50 Ω + approx. 0.7 V voltage drop due to reverse battery protection 0–10 V: 100 kΩ
<b>Accuracy/linearity:</b>	≤ ±0.3% of full scale value
<b>Temperature drift:</b>	≤ ±0.3% of full scale value
<b>Resolution:</b>	12 bit
<b>Reverse polarity protection:</b>	yes
<b>Overload proof:</b>	Yes (up to max. 30 V DC)

### **Analogue output**

<b>Note:</b>	The analogue output must be ordered using the ordering option "Option".
<b>Actual value output:</b>	4–20 mA (ordering option code A0) 0–20 mA (ordering option code B0) 0–10 V (ordering option code C0)
<b>Output type:</b>	Active
<b>On-load current:</b>	0–10 V: Max. 10 mA
<b>Load resistor:</b>	0/4–20 mA: Max. 600 Ω
<b>Accuracy/linearity:</b>	≤ ±1% of full scale value
<b>Temperature drift:</b>	≤ ±0.5% of full scale value

---

<b>Resolution:</b>	12 bit
<b>Short-circuit proof:</b>	yes
<b>Overload proof:</b>	Yes (up to max. 30 V DC)

***Programming input initialization (speed-AP function)***

<b>Input voltage:</b>	24 V DC
<b>Input current:</b>	1.3 mA at 24 V DC
<b>High level:</b>	>14 V DC
<b>Low level:</b>	< 8 V DC

***Travel sensor input (for travel length code S01 – remote potentiometer)***

<b>Supply voltage UP+:</b>	Typically 3.3 V DC
<b>Resistance range of remote potentiometers:</b>	1 to 10 k $\Omega$
<b>Input voltage range:</b>	0 to U <sub>P+</sub>
<b>Input resistance:</b>	1.2 M $\Omega$
<b>Accuracy/linearity:</b>	$\leq \pm 0.3\%$ of full scale value
<b>Temperature drift:</b>	$\leq \pm 0.3\%$ of full scale value
<b>Resolution:</b>	12 bit

**Positioner data**

**Note:**

Interferences to the set value signal can affect positioner activities

The following diagram is valid for valves with a standard assignment of the spindle position to the valve position.

(See section "Mechanical data, correlation between travel sensor spindle/valve position")

**Control diagram:**

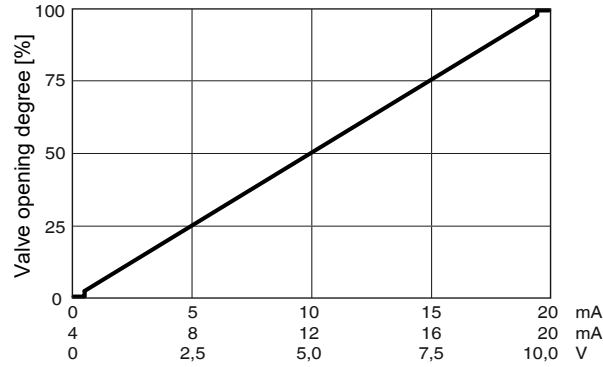

The GEMÜ 1434 µPos digital electro-pneumatic positioner automatically detects the control function of the valve during initialization: Normally open (NO) or normally closed (NC).

For the 0/4 mA or 0 V signal specification, the position of the valve is closed.

The close tight function integrated as standard ensures that the valve is moved completely to the end position when the signal Open or Close valve is given.

**System deviation (dead zone):**

- ≤ 1% (standard)
- ≤ 2% (K-no. 2442)
- ≤ 5% (K-no. 2443)

**Initialization:**

Automatic via 24 V DC signal

**Close tight function:**

- Closed:  $W \leq 0.5\%$
- Open:  $W \geq 99.5\%$

## Dimensions

### Direct mounting

Travel sensor version code 010/030

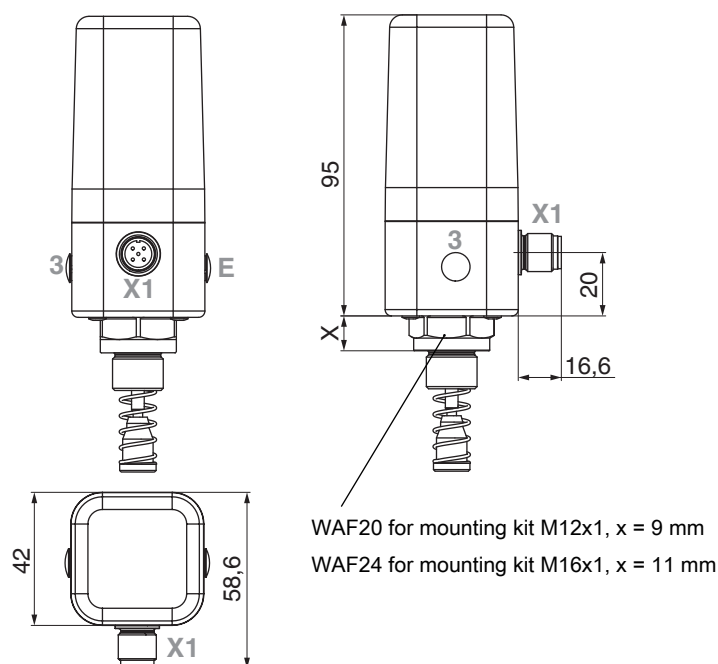
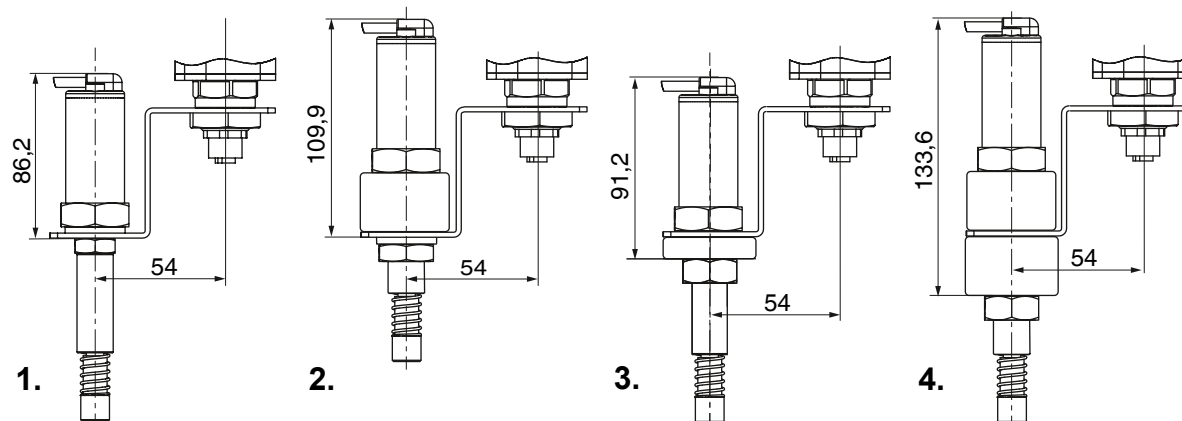

Figure including mounting kit

Dimensions in mm

### Direct mounting via mounting bracket

Travel sensor version code S01 + mounting kit 1444



Dimensions in mm

See mounting options – valve-specific GEMÜ 1444 000 Z... mounting kit

#### Version dependent on valve used

1. Normally closed valve, M16 adaption thread – standard
2. Normally closed valve, M16 adaption thread – special construction type for GEMÜ 9415
3. Normally closed valve, M22 adaption thread
4. Normally open or double acting valve, M16 or M22 adaption thread

**Remote mounting**

**Travel sensor version code S01**

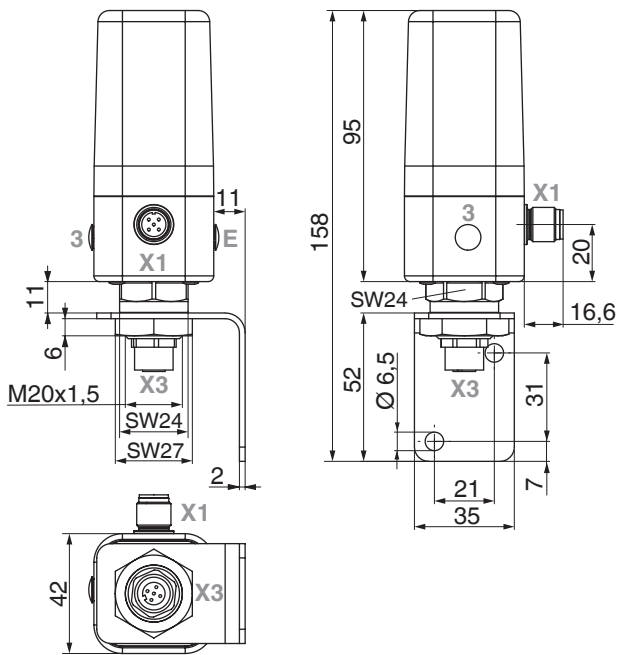
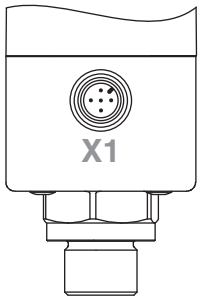

Figure including separately available mounting bracket

Dimensions in mm

## Electrical connection

### Position of the connectors



### Pin assignment

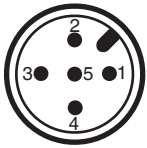

Pin	Signal name
1	Uv, 24 V DC supply voltage
2	I+/U+, set value input
3	I-/U-, GND Uv-
4	I+/U+, actual value output (optional)
5	U, initialization 24 V DC, started by an impulse signal t > 100 ms (speed <sup>-AP</sup> function)

## Version with external actual value potentiometer

**Note:** Ordering option Travel sensor version code S01

### Position of the connectors

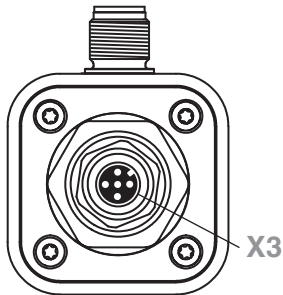

### Pin assignment



Pin	Signal name
1 <sup>1)</sup>	UP-, potentiometer output, supply voltage (-)
2	UPsig, potentiometer wiper voltage input
3 <sup>1)</sup>	UP+, output potentiometer supply voltage (+)
4	n.c.
5	n.c.

1) Potentiometer signal is processed internally inverted.

## Pneumatic connection

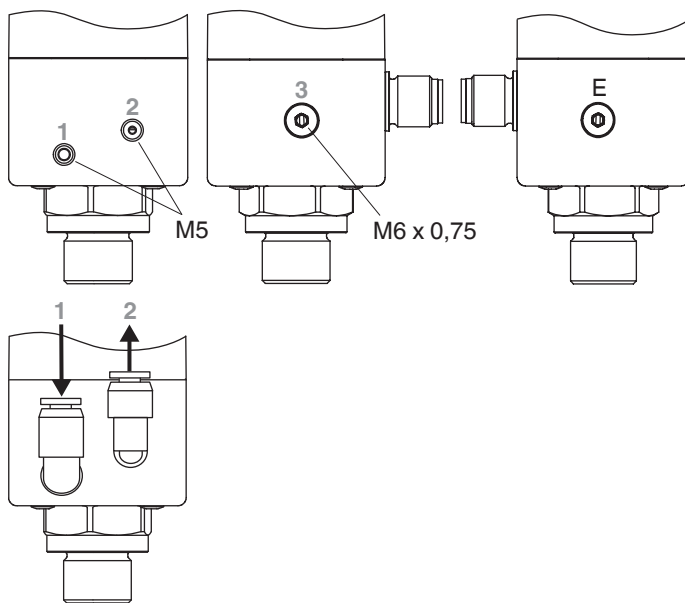

No.	Designation	Connection size
1	Air supply connection P	M5
2	Working connection for process valve A1	M5
3	Venting connection R with integrated check valve	M6 x 0.75*
E	Housing ventilation with integrated check valve	M6 x 0.75*

\* Only relevant for exhaust air duct and/or increase of protection class.

Fail safe function	
Error	Working connection A1
Electrical power supply failure	vented
Pneumatic supply failure	undefined
This fail safe function is not a substitute for specific plant safety requirements.	

Safety reaction	
Error	Working connection A1
Set value < 4.0 mA*	vented
Set value > 20 mA or 10 V	vented
* only for design with 4–20 mA set value input (code A)	

## Mounting options

### Direct mounting of the positioner

For direct mounting of the positioner on a valve, you need the following components

- GEMÜ 1434 positioner in travel sensor version code 010 or 030 (dependent on the stroke of the valve used)
- Valve-specific GEMÜ 1434 S01 Z... mounting kit for mounting the positioner

(At the time of ordering, specify the valve type with nominal size and control function)

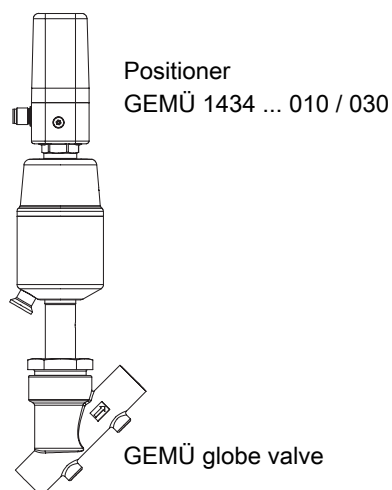

For direct mounting of the positioner on a valve with a stroke > 30 mm, you need the following components

- GEMÜ 1434 positioner in travel sensor version code S01 (remote potentiometer)
- Valve-specific GEMÜ 1444 000 Z... mounting kit with travel sensor and mounting bracket for mounting the positioner

(At the time of ordering, specify the valve type with nominal size and control function)

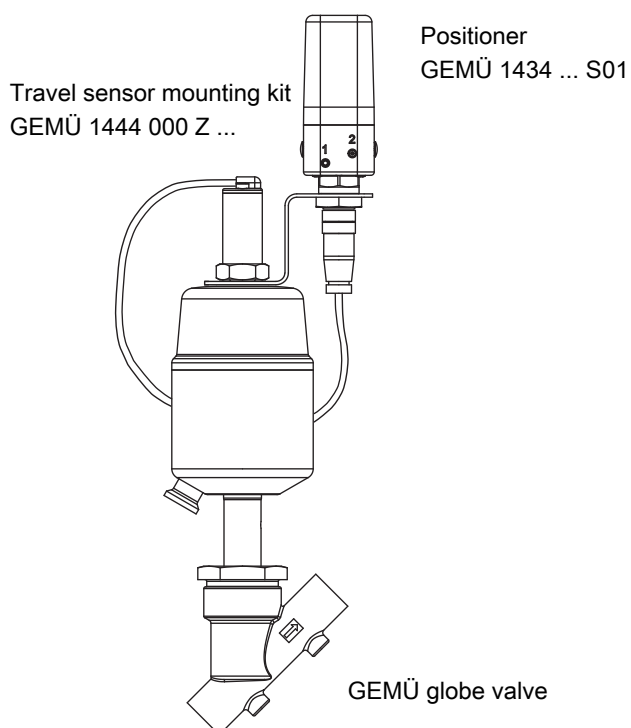

## Remote mounting of the positioner

For remote mounting of the positioner on a valve, you need the following components

- GEMÜ 1434 positioner in travel sensor version code S01
- GEMÜ 4232 000 Z ... 4001 travel sensor

(Travel sensor version dependent on the valve used, cable length dependent on the required distance between the valve and positioner)

- GEMÜ 4232 S01 Z... valve-specific mounting kit for mounting the travel sensor.
- GEMÜ 1434 000 Z MP mounting bracket (optional) for fixing the positioner

(At the time of ordering, specify the valve type with nominal size and control function and the required distance to the mounting location of the positioner)

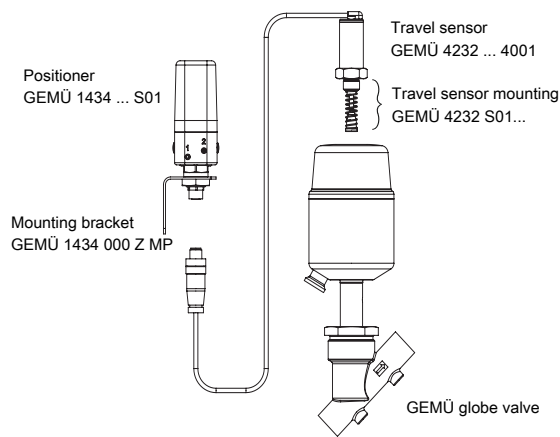

By using remote mounting and additional, deviating components, the valve can also be used in potentially explosive areas (provided that this is approved). In this case, the positioner must be installed outside the potentially explosive area and the connection with the travel sensor established via safety barriers.

The electrical connection and the installation must be carried out in accordance with the specifications in the operating instructions.

Applicable area (zone) dependent on the type of ignition protection of the valve or travel sensor.

The following deviating, supplementary components are to be used for this type of operation:

- Travel sensor in explosion-protected design GEMÜ 4232 ... 030/050/075 ... 0000 ... X  
Travel sensor version dependent on the valve used, cable length dependent on the distance between the critical (potentially explosive) and safe zone
- Connector between travel sensor and positioner, GEMÜ 1219000Z0300SG00M0M125A, order number: 88208779
- Safety barrier A two-channel, safety barrier P626, order number: 99014203 \*
- Safety barrier B one-channel, safety barrier P630, order number: 99014207 \*

\* Alternative safety barriers with similar characteristics can be used on-site – technical properties available on request

## Accessories



### GEMÜ 1219

#### Cable socket / cable plug M12

The GEMÜ 1219 is a connector (cable socket / cable plug) M12, 5-pin. Straight and/or 90° angled plug type. Defined cable length or with threaded connection without cable. Various materials available for the threaded ring.

Suitable for electrical connection of the connector X1

Description	Length	Order number
5-pin, angle	without cable	88205545

**GEMÜ 1219****Cable socket / cable plug M12**

The GEMÜ 1219 is a connector (cable socket / cable plug) M12, 5-pin. Straight and/or 90° angled plug type. Defined cable length or with threaded connection without cable. Various materials available for the threaded ring.

Description	Length	Order number
	2 m cable	88205534
	5 m cable	88205540
	10 m cable	88210911
	15 m cable	88244667
5-pin, straight	without cable	88205544
	2 m cable	88205542
	5 m cable	88205543
	10 m cable	88270972
	15 m cable	88346791

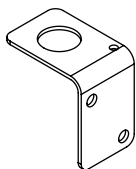
**GEMÜ 1434 000 ZMP****Mounting bracket**

Mounting bracket for wall mounting (for remote mounting)

Designation	Order number
1434 000 ZMP	88280481

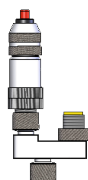
**GEMÜ 1434 000 ZIK****Initialization kit**

The GEMÜ 1434 000 ZIK initialization kit is intended for on-site initializing of GEMÜ 1434  $\mu$ Pos and GEMÜ 1436 eco cPos intelligent positioners. The initialization kit is connected to the system's connection cable on the one side and to the positioner's connector plug on the other. You can disconnect it again when initialization is complete.

Designation	Order number
1434 000 ZIK	88277921



GEMÜ Gebr. Müller Apparatebau GmbH & Co. KG  
Gert-Müller-Platz 1, 74635 Kupferzell, Germany  
Phone +49 (0) 7940 1230 · info@gemue.de  
www.gemu-group.com