

GEMÜ C53 iComLine

Motorized control valve



Features

- Control valve for ultra pure applications in the semiconductor industry
- High-resolution linear actuator with stepper motor
- Integration in space-saving multi-port valve block solutions
- Long service life with over 1 million qualified control switching cycles
- Clean room production, fulfils SEMI F57
- Ideally suited for corrosive media
- Control valve based on the iComLine series

Description

The GEMÜ C53 iComLine 2/2-way diaphragm globe valve was developed for precise and demanding control applications in semiconductor production. The sealing concept of the valve is based on the tried-and-tested GEMÜ PD design, whereby the actuator and medium are separated by a PTFE regulating cone. As the regulating cone contour, actuator stroke and connection size can be adapted, the GEMÜ C53 iComLine satisfies virtually all control and flow requirements of the semiconductor industry. The precise stepper motor, in conjunction with the ultra-pure body materials, is particularly suitable for lithography, CMP, and etching processes, as well as analytical applications in semiconductor production.

Technical specifications

- **Media temperature:** 10 to 150 °C
- **Ambient temperature:** 0 to 40 °C
- **Operating pressure:** 0 to 6 bar
- **Connection sizes:** 1/4" to 3/4"
- **Body configurations:** Straight through body
- **Connection types:** Flare | PrimeLock® | Super 300 Type Pillar®
- **Body materials:** Modified PTFE | PFA
- **Seal material:** PTFE
- **Supply voltage:** 24 V DC
- **Input signals:** 0–10 V | 4–20 mA
- **Actuating speed:** Max. 2 mm/s
- **Valve stroke:** 4 mm
- **Protection class:** IP65

Technical data depends on the respective configuration



Product description

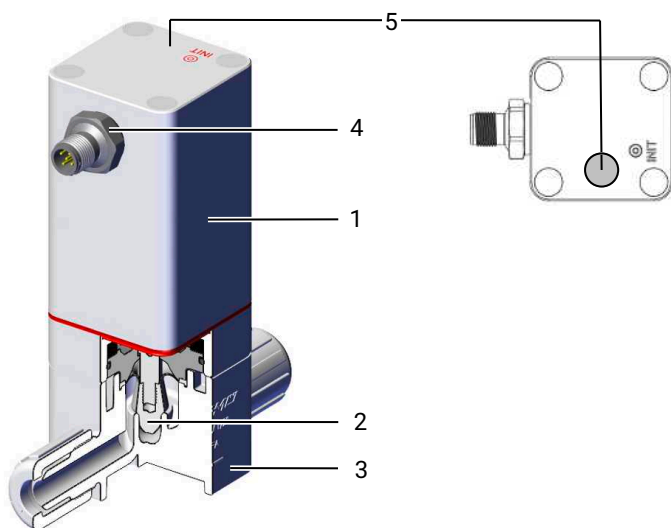

No.	Name	Materials
1	Actuator	External actuator parts made of PVDF
2	Control PD	Modified PTFE
3	Valve body	PFA, PTFE
4	Electrical connection	PPS
5*	Display of status LED	

* Status LED available from device version 01 for control modules with codes S0, S1, S2 (see operating instructions – product label)

Functional description

Control module code ¹⁾	Fail-safe position	Function
S0	Hold	Actuator stays in the approached position
S1	Close	Actuator moves to CLOSED position
S2	Open	Actuator moves to OPEN position
V0	Hold	Actuator stays in the approached position
V1	Close	Actuator moves to CLOSED position

1) Control module

Code S0: Positioner 4–20 mA Hold safety position

Code S1: Positioner 4–20 mA Close error position

Code S2: Positioner 4–20 mA Open safety position

Code V0: Positioner 0–10 V Hold safety position

Code V1: Positioner 0–10 V Close error position

Availability

Connection size	Connection type		
	Flare (code 73, 75 77), PrimeLock (code PL)	Flare (code 73, 75 77), PrimeLock (code PL)	Super 300 Pillar (code 79)
	Valve body material		
	PFA (code 30)	PTFE (code 26, SP)	PTFE (code 26, SP)
1/4"	-	X	X
3/8"	-	X	X
1/2"	X	-	X
3/4"	X	-	X

Order data

The order data provide an overview of standard configurations.

Please check the availability before ordering. Other configurations available on request.

Order codes

1 Type	Code
Plastic globe valve, electrical	C53

2 Connection size	Code
1/4", international code: 4	4
3/8", international code: 6	6
1/2", international code: 8	8
3/4", international code: 12	12

3 Body configuration	Code
2/2-way body	D

4 Connection type	Code
Flare connection with CPFA union nut	73
Flare connection with PVDF union nut	75
Flare connection with PFA union nut	77
Super 300 type Pillar connection	79
PrimeLock connection	PL

5 Valve body material	Code
PFA, perfluoroalkoxy	30
Modified PTFE, polytetrafluoroethylene	26
PTFE polytetrafluoroethylene, white	SP

6 Seal material	Code
PTFE	5

7 Voltage/Frequency	Code
24 V DC	C1

8 Control module	Code
Positioner 4–20 mA Hold safety position	S0
Positioner 4–20 mA Close error position	S1

8 Control module	Code
Positioner 4–20 mA Open safety position	S2
Positioner 0–10 V Hold safety position	V0
Positioner 0–10 V Close error position	V1

9 Actuator version	Code
Actuator size 2 Seat diameter 9.55 mm	2A

10 Regulating cone	Code
Version 1	
0.18 m ³ /h – linear	R3505
0.25 m ³ /h – linear	R3506
0.44 m ³ /h – linear	R3442
Version 2	
0.26 m ³ /h – mod.EQ	R3509
0.68 m ³ /h – mod.EQ	R3510
0.77 m ³ /h – mod.EQ	R3234
Version 3	
0.26 m ³ /h – linear	R3507
0.78 m ³ /h – linear	R3508
0.89 m ³ /h – linear	R3235
Version 4	
0.22 m ³ /h – linear	R3511
0.85 m ³ /h – linear	R3512
1.25 m ³ /h – linear	R3395
Version 5	
0.06 m ³ /h – linear	R3486

11 High Purity version	Code
High Purity	HP

Order example

Ordering option	Code	Description
1 Type	C53	Plastic globe valve, electrical
2 Connection size	12	3/4", international code: 12
3 Body configuration	D	2/2-way body
4 Connection type	75	Flare connection with PVDF union nut
5 Valve body material	30	PFA, perfluoroalkoxy
6 Seal material	5	PTFE
7 Voltage/Frequency	C1	24 V DC
8 Control module	S1	Positioner 4–20 mA Close error position

Order data

Ordering option	Code	Description
9 Actuator version	2A	Actuator size 2 Seat diameter 9.55 mm
10 Regulating cone	R3235	0.89 m ³ /h – linear
11 High Purity version	HP	High Purity

Technical data

Medium

Working medium: Corrosive, inert, gaseous and liquid media which have no negative impact on the physical and chemical properties of the body and diaphragm material.

Temperature

Media temperature: 10 – 150 °C
Observe pressure/temperature diagram

Ambient temperature: 0 – 40 °C

Storage temperature: -10 – 40 °C

Pressure

Operating pressure: 0 – 6 bar

Pressure/temperature diagram:

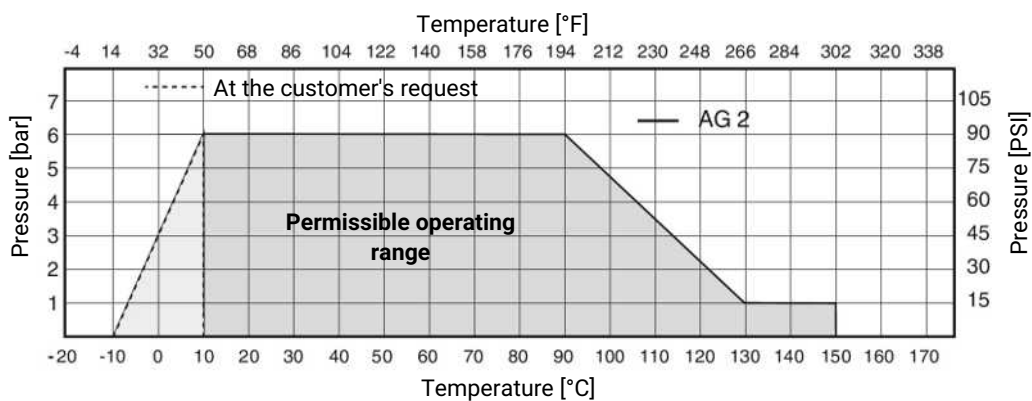

Kv values:

Version 1 – flow range: 0.8–7.3 l/min (linear)

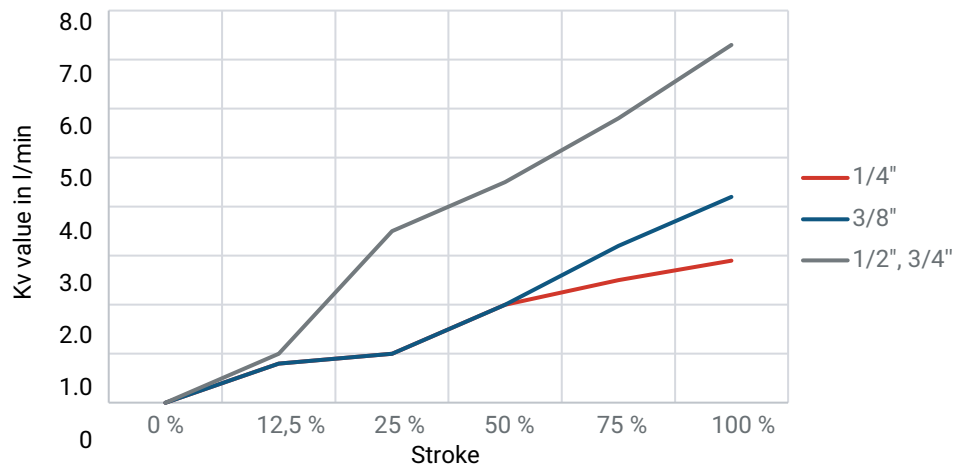

Stroke in %	R3505	R3506	R3442
	1/4"	3/8"	1/2", 3/4"
0.0	0.0	0.0	0.0
12.5	0.8	0.8	1.0
25.0	1.0	1.0	3.5
50.0	2.0	2.0	4.5
75.0	2.5	3.2	5.8
100.0	2.9	4.2	7.3

Kv values in l/min

Version 2 – flow range: 2.0–12.8 l/min (equal-percentage)

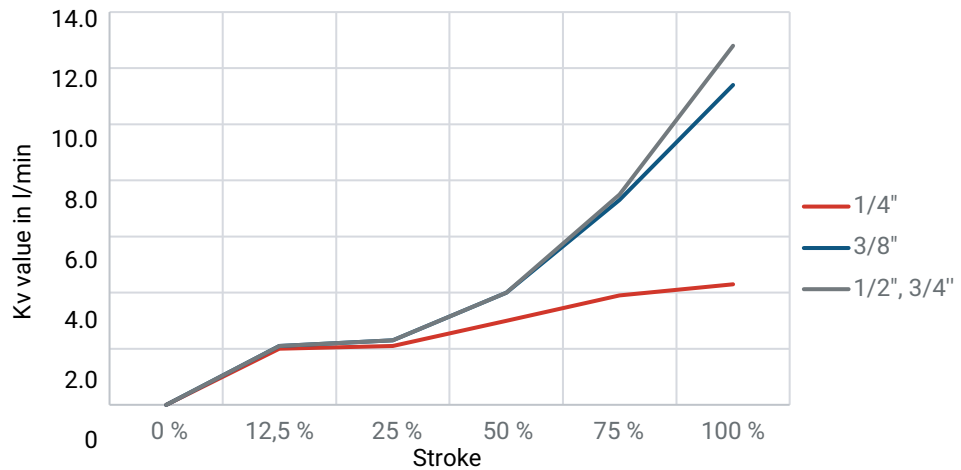

Stroke in %	R3509	R3510	R3234
	1/4"	3/8"	1/2", 3/4"
0.0	0.0	0.0	0.0
12.5	2.0	2.1	2.1
25.0	2.1	2.3	2.3
50.0	3.0	4.0	4.0
75.0	3.9	7.3	7.5
100.0	4.3	11.4	12.8

Kv values in l/min

Kv values:

Version 3 – flow range: 2.2–14.8 l/min (linear)

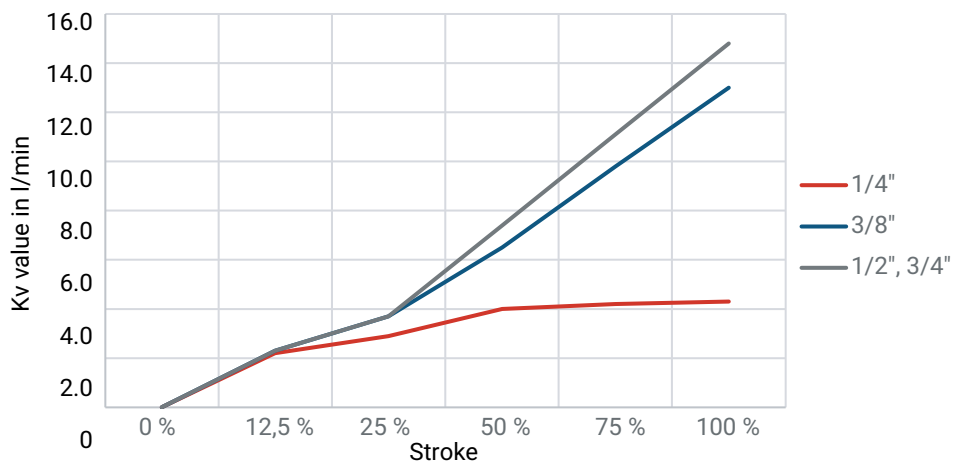

Stroke in %	R3507	R3508	R3235
	1/4"	3/8"	1/2", 3/4"
0.0	0.0	0.0	0.0
12.5	2.2	2.3	2.3
25.0	2.9	3.7	3.7
50.0	4.0	6.5	7.4
75.0	4.2	9.8	11.1
100.0	4.3	13.0	14.8

Kv values in l/min

Version 4 – flow range: 2.2–20.8 l/min (linear)

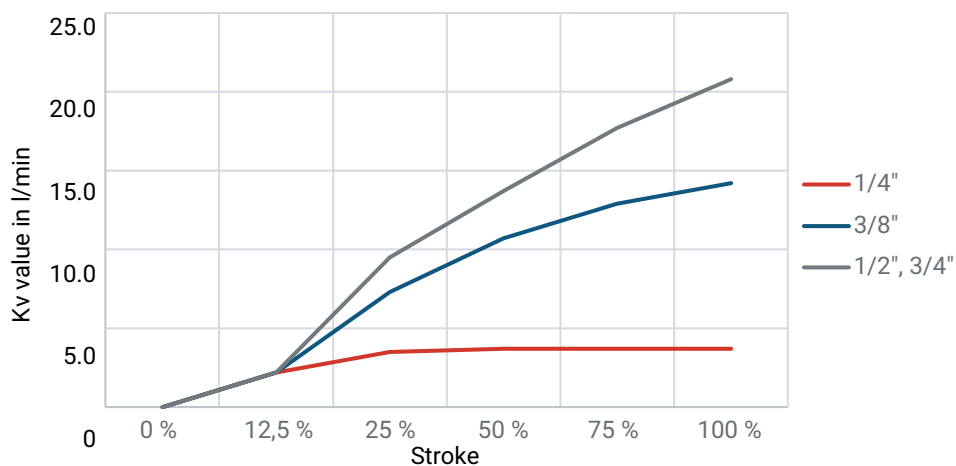

Stroke in %	R3511	R3512	R3395
	1/4"	3/8"	1/2", 3/4"
0.0	0.0	0.0	0.0
12.5	2.2	2.2	2.2
25.0	3.5	7.3	9.5
50.0	3.7	10.7	13.7
75.0	3.7	12.9	17.7
100.0	3.7	14.2	20.8

Kv values in l/min

Kv values:

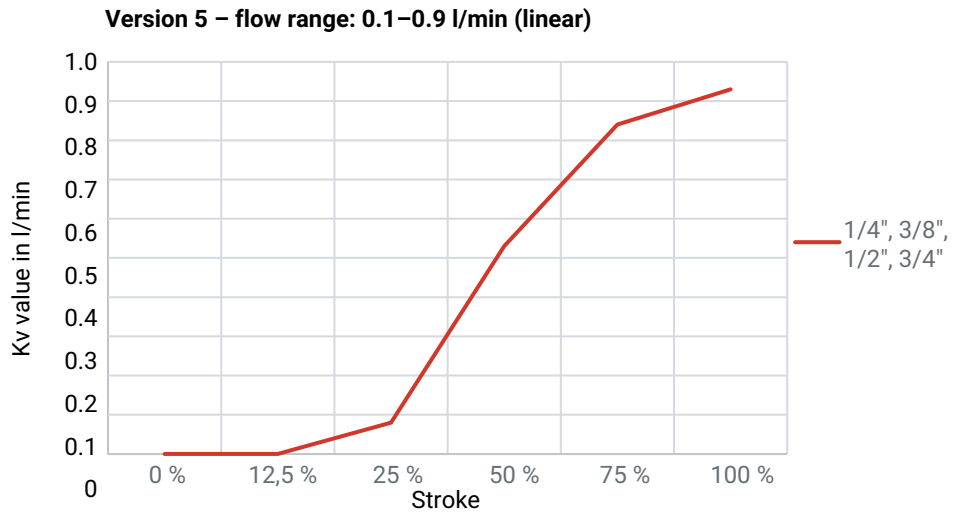

Stroke in %	R3486
	1/4", 3/8", 1/2", 3/4"
0.0	0.0
12.5	0.0
25.0	0.08
50.0	0.53
75.0	0.84
100.0	0.93

Kv values in l/min

Vacuum: 400 mbar absolute

Product conformities

- Machinery Directive:** 2006/42/EC
- EMC Directive:** 2014/30/EU
- Interference resistance:** DIN EN 61000-6-2 (Nov. 2019)
- Interference emission:** DIN EN 61000-6-4

Mechanical data

Protection class: IP 65 acc. to EN 60529

Weight:

Connection size	Weight
1/4"	660 g
3/8"	660 g
1/2"	600 g
3/4"	600 g

Duty cycle and service life

Service life: **Open / Close duty** - Minimum 1,000,000 switching cycles at room temperature and permissible duty cycle.

Control operation – Class C acc. to EN 15714-2 (± 1,800,000 start-ups).

Duty cycle: 60% duty

Electrical data

Supply voltage

Voltage:	24 V DC \pm 10%
Rating:	\leq 24 W (24 V DC)
Reverse polarity protection:	Yes

Analogue input signals

Set value as current signal, control module code S0 / S1 / S2

Input signal:	4–20 mA
Input type:	passive
Input resistance:	50 Ω
Control accuracy:	\pm 1%

Set value as voltage signal, control module code V0 / V1

Input signal:	0–10 V
Input type:	passive
Input resistance:	110 K Ω
Control accuracy:	\pm 1%

Digital input signals

Function:	Initialization of the positioner
Voltage:	24 V DC
Logic level "1":	$>$ 15 V DC
Logic level "0":	\leq 5 V DC

Analogue output signals

Actual value as current signal, control module code S0 / S1 / S2

Output signal:	4–20 mA
Output type:	Active
Load resistor:	650 Ω
Short-circuit proof:	Yes

Actual value as voltage signal, control module code V0 / V1

Output signal:	0–10 V
Output type:	Active
Short-circuit proof:	Yes

Behaviour in the event of an error

- Function:** In the event of an error the valve moves to the error position.
Notes: Moving to the error position is only possible with full power supply. This behaviour is not a safety position. The valve must be operated with a GEMÜ 1571 emergency power supply module (see accessories) to ensure the function in case of voltage loss.
- Error position:**
- Hold - Actuator stays in the approached position (control module S0 and V0)
 - Close - Actuator moves to the Closed position (control module S1 and V1)
 - Open - Actuator moves to the Open position (control module S2)

Dimensions

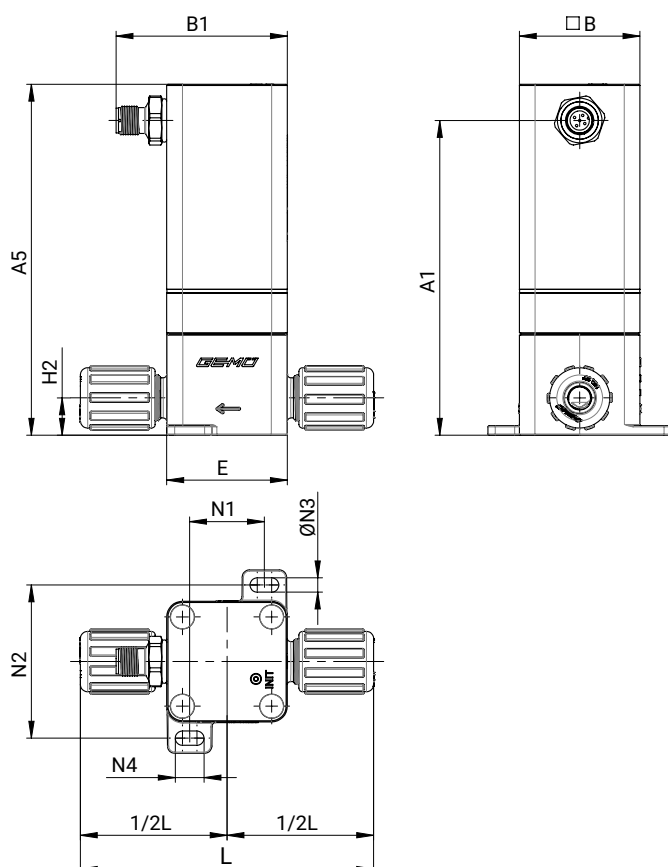

Con- nection size	Actu- ator version	Con- nection	A1	A5	□B	B1	E	H2	L	N1	N2	ØN3	N4
1/4"	2A	Flare	131.0	146.0	50.0	71.0	50.0	16.0	111.0	71.0	49.0	6.0	12.0
		Prime- Lock	131.0	146.0	50.0	71.0	50.0	16.0	109.0	71.0	49.0	6.0	12.0
		Pillar	131.0	146.0	50.0	71.0	50.0	16.0	88.0	71.0	49.0	6.0	12.0
3/8"	2A	Flare	131.0	146.0	50.0	71.0	50.0	16.0	117.8	71.0	49.0	6.0	12.0
		Prime- Lock	131.0	146.0	50.0	71.0	50.0	16.0	113.0	71.0	49.0	6.0	12.0
		Pillar	131.0	146.0	50.0	71.0	50.0	16.0	100.0	71.0	49.0	6.0	12.0
1/2"	2A	Flare	131.0	146.0	50.0	71.0	50.0	16.0	121.6	31.0	63.5	6.0	12.0
		Prime- Lock	131.0	146.0	50.0	71.0	50.0	16.0	120.0	31.0	63.5	6.0	12.0
		Pillar	131.0	146.0	50.0	71.0	50.0	16.0	108.0	71.0	49.0	6.0	12.0
3/4"	2A	Flare	131.0	146.0	50.0	71.0	50.0	16.0	128.0	31.0	63.5	6.0	12.0
		Prime- Lock	131.0	146.0	50.0	71.0	50.0	16.0	128.0	31.0	63.5	6.0	12.0
		Pillar	131.0	146.0	50.0	71.0	50.0	16.0	108.0	71.0	49.0	6.0	12.0

Dimensions in mm

Electrical connection

Position of the connectors

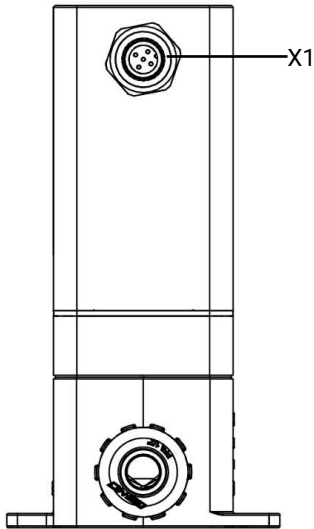

Electrical connection

Connection X1

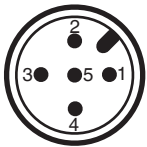

Five-pin M12 built-in socket, A-coded

Pin	Signal name
1	24 V supply voltage
2	I+/U+, set value input
3	GND
4	I+/U+, actual value output
5	Digital input 1 / tube replacement function

Qualification of the valve

Bursting pressure at room temperature

Valve	Component	Test conditions	Required criteria
C53	Valve body	Maintain defined water pressure for 10 minutes, if OK, increase water pressure until leakage is detected.	No leakage externally. Bursting pressure = 5.8 x P max. (35.0 bar)

Service life at room temperature

Valve	Component	Test conditions	Required criteria
C53	Valve	Valves switched at room temperature, medium pressure 6 bar, water, full stroke	No leakage externally or via the seat for up to 1 million switching cycles*
C53	Valve	Valves switched at room temperature, medium pressure 6 bar, water, 20% control stroke	No leakage externally or via the seat for up to 1 million switching cycles*

Hot oil inspection

Valve	Component	Test conditions	Required criteria
C53	Valve	Valves switched at 150 °C hot oil, medium pressure 2 bar, full stroke, seals tightly	No leakage externally or via the seat 300,000 switching cycles* every 2 weeks

Hot water test

Valve	Component	Test conditions	Required criteria
C53	Valve	Valves switched at 90 °C hot water, medium pressure 2.1 bar, full stroke, seals tightly	No leakage externally or via the seat 200,000 switching cycles* every 2 weeks

Temperature change test

Valve	Component	Test conditions	Required criteria
C53	Valve	Valves not switched at -15 °C/+70 °C in temperature changes, no medium, no pressure, cycle time 4 hours	Protection class inspection IP 65 passed, no penetration of humidity into the actuator can be detected

Vacuum test

Valve	Component	Test conditions	Required criteria
C53	Valve	Closed for 2 weeks	Valve fully open at -930 mbar (relative)

Positioner inspection

Valve	Component	Test conditions	Required criteria
C53	Control actuator	Modulation test 10% stroke, 20% force, at room temperature	1.8 million start-ups

Shock and vibration

Valve	Component	Test conditions	Required criteria
C53	Valve	Vibration test acc. to EN 60068-2-6 test Fc Shock test acc. to EN 60068-2-27 test Ea	Function OK before and after test

* All concluding tests were carried out at testing pressure at room temperature.
Seat leak tightness: PSx1.1 =(6.6 bar). External leak tightness: PSx1.5 =(9 bar).

Accessories



GEMÜ 1219

Cable socket / cable plug M12

The GEMÜ 1219 is a connector (cable socket / cable plug) M12, 5-pin. Straight and/or 90° angled plug type. Defined cable length or with threaded connection without cable. Various materials available for the threaded ring.

Description	Length	Material	Item number
5-pin, angle	without cable	PA	88208750
	2 m cable	PA/PUR	88221316
	5 m cable	PA/PUR	88279160
	2 m cable	PA/PTFE	88708098
	5 m cable	PA/PTFE	88708099
	10 m cable	PA / PVC	88708102
5-pin, straight	without cable	PA	88208749
	2 m cable	PA/PUR	88353742
	5 m cable	PA/PUR	88440263
	2 m cable	PA/PTFE	88708100
	5 m cable	PA/PTFE	88708101



GEMÜ 1571

Emergency power supply module

The GEMÜ 1571 capacitive emergency power supply module is suitable for valves with motorized actuators such as GEMÜ eSyStep and eSyDrive as well as the GEMÜ C53 iComLine control valve. In the event of a power failure, the product provides an uninterrupted power supply so that the valve can be moved to the safety position. The emergency power supply module is available individually or with an expansion module and can supply several valves. The input and output voltage is 24 V.

GEMÜ 1571 emergency power supply module			
Input voltage	Output voltage	Capacity	Item number
24 V	24 V	1700 Ws	88660398
24 V	24 V	13200 Ws	88751062



GEMÜ 1573

Switching power supply unit

The GEMÜ 1573 switching power supply unit converts unstable input voltages from 100 to 240 V AC into a continuous DC voltage. It can be used as an accessory for valves with motorized actuators e. g. GEMÜ eSyLite, eSyStep und eSyDrive and for additional devices with a 24 V DC power supply. Different power levels, output currents and a 48 V DC version for servoDrive actuators are available.

Description	Input voltage	Output voltage	Output current	Item number
Power supply unit 24 V, 5 A	100–240 V AC	24 V DC	5 A	88660400
Power supply unit 24 V, 10 A	100–240 V AC	24 V DC	10 A	88660401



GEMÜ Gebr. Müller Apparatebau GmbH & Co. KG
Gert-Müller-Platz 1, 74635 Kupferzell, Germany
Phone +49 (0) 7940 1230 · info@gemue.de
www.gemu-group.com