

## GEMÜ R487 Victoria

### Manually operated butterfly valve



### Features

- Low torques thanks to PTFE coated bushes
- Bubble tight sealing acc. to EN 12266-1/P12, leakage rate A
- Liner material is easy to read when installed
- Sleek disc design for higher Kv values
- Robust body coating comparable to ISO 12944-6 C5
- Various actuator types can be selected
- Optional accessories are installed, set and tested so they are ready for operation

### Description

The GEMÜ R487 Victoria soft seated metal butterfly valve is manually operated. It has a hand lever or gearbox depending on customer requirements. The butterfly valve is available in nominal sizes DN 25 to 600 and in standard installation lengths ISO 5752/20 | EN 558-1/20 | API 609 category A (DIN 3202 K1) in wafer, lug and U section body versions.

### Technical specifications

- **Media temperature:** -10 to 160 °C
- **Ambient temperature:** -10 Up to 70 °C
- **Operating pressure :** 0 Up to 16 bar
- **Nominal sizes:** DN 25 to 600
- **Housing configurations:** Lug | U section | Wafer
- **Connection standards :** ANSI | AS | BS | DIN | EN | ISO | JIS
- **Body materials:** EN-GJS-400-15, SG iron material | EN-GJS-400-18-LT (GGG 40.3)
- **Body coating:** Epoxy
- **Liner materials:** EPDM | FKM | NBR | SBR, abrasion resistant | Silicone
- **Disc materials:** 1.4408, investment casting material | 1.4408, polished investment casting material | 1.4469, Duplex cast steel material | EN-GJS-400-15, SG iron material
- **Disc coating:** Epoxy | Halar® | Rilsan®
- **Conformities:** ACS | ASME GEMÜ B31.3 | ATEX | Belgaqua | DNV GL | DVGW Drinking water | DVGW Gas | FDA | FMEDA | NSF | Oxygen | Regulation (EC) No. 1935/2004 | TA Luft (German Clean Air Act) | WRAS

Technical data depends on the respective configuration



further information  
webcode: GW-R487



## Product line



**GEMÜ R480**  
Victoria



**GEMÜ R481**  
Victoria



**GEMÜ R487**  
Victoria



**GEMÜ R488**  
Victoria

### Operation

With bare shaft	●	-	-	-
manually	-	-	●	-
Pneumatic	-	●	-	-
Motorized	-	-	-	●
<b>Nominal sizes</b>	DN 25 to 600	DN 25 to 600	DN 25 to 600	DN 25 to 600
<b>Media temperature</b>	-10 to 160 °C	-10 to 160 °C	-10 to 160 °C	-10 to 160 °C
<b>Operating pressure</b>	0 to 16 bar	0 to 16 bar	0 to 16 bar	0 to 16 bar

### Connection types

Flange (lug)	●	●	●	●
Flange (U section)	●	●	●	●
Flange (wafer)	●	●	●	●

### Conformities

ACS	●	●	●	●
ASME GEMÜ B31.3	●	●	●	●
ATEX	●	●	●	●
Belgaqua	●	●	●	●
DNV GL	●	●	●	●
DVGW Drinking water	●	●	●	●
DVGW Gas	●	●	●	●
FDA	●	●	●	●
FMEDA	●	●	●	●
NSF	●	●	●	●
Oxygen	●	●	●	●
Regulation (EC) No. 1935/2004	●	●	●	●
TA Luft (German Clean Air Act)	●	●	●	●
WRAS	●	●	●	●

## Product description

### Construction

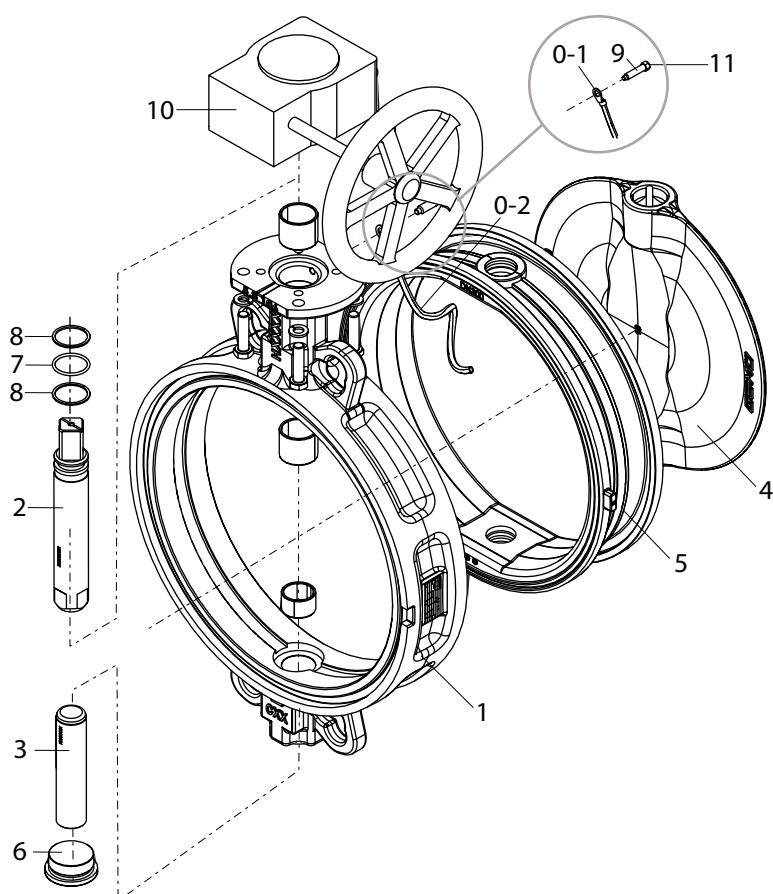

Item	Name	Materials
1	Body	SG iron 5.3106, epoxy coated (RAL 5021)
2	Shaft	1.4021
3	Axis	1.4021
4	Disc	Various materials (see order data)
5	Liner	Various materials (see order data)
6	Threaded plug	1.4408
7	O-ring	NBR
8	Support rings	PTFE
9	Hexagon head bolts	Stainless steel A2-70
0	Earthing kit for ATEX version	
0-1	Cable lug (ATEX version)	
0-2	Stranded wire (ATEX version)	
10	Manual actuator	Aluminium, polyurethane coated GG25, polyurethane coated
11	CONEXO RFID chip	

## Actuator assignment

### Latching hand lever assignment, aluminium (AHL)

Operating pressure	DN	Actuator flange	Designation	Code
10 bar, 16 bar	25 – 50	F05	AHL.F0509.200	AHL09
	65, 80	F05	AHL.F0511.200	AHL11
	100	F07	AHL.F0514.200	AHL14
	125, 150	F07	AHL.F0717.270	AHL17
	200*	F10	AHL.F1022.340	AHL22
3 bar	250*	F10	AHL.F1017.340	AHL22

\*For manual operation, we recommend a gearbox for these nominal sizes

### Latching hand lever assignment, stainless steel (VHL)

Operating pressure	DN	Actuator flange	Designation	Code
10 bar, 16 bar	25 – 100*	F05	VHL F0514. 195	VHL14
	80 – 150	F07	VHL F0717. 267	VHL17
	200	F10	VHL F1022. 330	VHL22

\*DN 80, 100 not for lug bodies

### Continuously adjustable hand lever assignment, aluminium (SAHL)

Operating pressure	DN	Actuator flange	Designation	Code
3 bar, 6 bar, 10 bar, 16 bar	25 – 50	F05	SAHL.F0509.200	SAHL09
	65, 80	F05	SAHL.F0511.200	SAHL11
	100	F05	SAHL.F0514.200	SAHL14
	125 – 150	F07	SAHL.F0717.270	SAHL17

### Handwheel with gearbox assignment

Operating pressure	DN	Actuator flange	Designation	Code
3 bar, 10 bar, 16 bar	25 – 50	F05	GB23205F05-F07D9 PS100	GB232
	65, 80	F05	GB23205F05-F07D11 PS100	GB232
	100	F05	GB23205F05-F07D14 PS100	GB232
	125	F05	GB23206F05-F07D17 PS100	GB232
	150	F05	GB23206F05-F07D17 PS160	GB232
	200 – 300	F07	GB23208F07-F10D22 PS200	GB232
	350	F10	GB23214F10-F12D27 SG500	GB232
	400	F14	GB23214 F14D36 SG500	GB232
	450, 500	F10	GB880NF10-F14D36 SG800	GB880N
	600	F12	GB1250NF12-F16D46 SG700	GB1250N

## Product conformities

	Approved designs			Special function (code)
	Disc material	Liner material	Liner fixing	
<b>Drinking water</b>				
ACS	CF8M, 1.4408 (code A) CF8M, 1.4408 polished (code B) Super Duplex, 1.4469 (code D) EN-GJS-400-15 (GGG-40), epoxy coated (code E) EN-GJS-400-15, GGG40 Rilsan® PA11 coated (code R)	EPDM (code W)	All versions	A
Belgaqua	CF8M, 1.4408 (code A) CF8M, 1.4408 polished (code B) Super Duplex, 1.4469 (code D)	EPDM (code W)	Loose (code L)	B
DVGW Water	CF8M, 1.4408 (code A) CF8M, 1.4408 polished (code B) Super Duplex, 1.4469 (code D)	EPDM (code W)	Loose (code L)	D
NSF	CF8M, 1.4408 (code A) CF8M, 1.4408 polished (code B) Super Duplex, 1.4469 (code D)	EPDM (code W)	All versions	N
WRAS	CF8M, 1.4408 (code A) CF8M, 1.4408 polished (code B) Super Duplex, 1.4469 (code D)	EPDM (code W)	All versions	W
<b>Food</b>				
FDA	CF8M, 1.4408 (code A) CF8M, 1.4408 polished (code B) Super Duplex, 1.4469 (code D)	EPDM-AB/W (code I) EPDM, white (code M) NBR, white (code U) EPDM-HT (code Z)	Loose (code L)	no order code required
Regulation 1935/2004	CF8M, 1.4408 polished (code B)	EPDM, white (code M) NBR (W) (code U) NR, white (code I) EPDM-HT (code Z)	Loose (code L)	no order code required
<b>Gas</b>				
DVGW Gas	CF8M, 1.4408 (code A) CF8M, 1.4408 polished (code B)	NBR (code J)	Loose (code L)	G
<b>Oxygen</b>				
Oxygen	CF8M, 1.4408 (code A) CF8M, 1.4408 polished (code B)	EPDM (code E)	All versions	O
<b>Air</b>				
TA Luft (German Clean Air Act)	All materials	All materials	All versions	no order code required
<b>Ship approval</b>				
DNV GL	All materials	All materials	All versions	S

Availabilities - Type of design

	Approved designs			Special function (code)
	Disc material	Liner material	Liner fixing	
<b>Explosion protection</b>				
ATEX internal and external	CF8M, 1.4408 (code A) CF8M, 1.4408 polished (code B) Super Duplex, 1.4469 (code D) 2.0975/CC333G (code G) 1.4435/ASTM A351/CF3M/AISI 316L (code I)	EPDM (code E) SBR (code F) NBR (code N) ECO (code C) EPDM-HT (code Z)	All versions	Y
ATEX external	All materials	All materials	All versions	X
<b>Functional safety</b>				
Functional safety	All materials	All materials	All versions	no order code required
<b>Pressure equipment standards</b>				
ASME GEMÜ B31.3 (DN 25–350)	All materials	All materials	All versions	P, N
2014/68/EU	All materials	All materials	All versions	no order code required

Other features are not relevant for the product conformities

## Availabilities - Type of design

Type of design (code) <sup>1)</sup>	
<b>0101</b>	All except liner code V, EPDM-HT code Z and silicone code S
<b>1782</b>	Only disc material code B

All other types of design can be freely combined.

1) **Type of design**

Code 0101: Media-wetted area cleaned to ensure suitability for paint applications, parts sealed in plastic bag

Code 1782: Stainless steel valve disc, without lettering, mechanically polished to 1.6 µm and electropolished, spigot internally polished to 1.6 µm, no polishing of internal threads

## Order data

Other configurations available on request. Please check the availability with GEMÜ before ordering.

Products ordered with **bold marked ordering options** are so-called preferred series. Depending on the nominal size, these are available more quickly.

## Order codes

1 Type	Code
Butterfly valve, manually operated, body with C5-M coating (min. 250 µm) and integrated leakage groove, blow-out proof shaft with dust protection, multiple bearings through PTFE bushing, multiple sealing system with insertion slope, material easy to read when installed	R487

2 DN	Code
DN 25	25
DN 32	32
DN 40	40
DN 50	50
DN 65	65
DN 80	80
DN 100	100
DN 125	125
DN 150	150
DN 200	200
DN 250	250
DN 300	300
DN 350	350
DN 400	400
DN 450	450
DN 500	500
DN 600	600

3 Body configuration	Code
Flange-mounted design (lug), face-to-face dimension FTF EN 558 series 20	L
Double flange design (U section), face-to-face dimension FTF EN 558, series 20	U
Wafer-type flange design, face-to-face dimension FTF EN 558 series 20	W

4 Operating pressure	Code
3 bar	0
<b>6 bar</b>	<b>1</b>
10 bar	2
<b>16 bar</b>	<b>3</b>

5 Connection type	Code
PN 6/flange EN 1092, face-to-face dimension FTF EN 558 series 20	1
PN 10/flange EN 1092, face-to-face dimension FTF EN 558 series 20	2
PN 16/flange EN 1092, face-to-face dimension FTF EN 558 series 20	3

5 Connection type	Code
ANSI B16.5, class 150, face-to-face dimension FTF EN 558 series 20	D
Flange BS 10 Tab E, face-to-face dimension FTF EN 558, series 20	S
Flange AS 2129 Tab D, face-to-face dimension FTF EN 558, series 20	T
Flange AS 2129 Tab E, face-to-face dimension FTF EN 558, series 20	U
Flange BS 10 Tab D, face-to-face dimension FTF EN 558, series 20	H
JIS 10 K, face-to-face dimension FTF EN 558, series 20	G
JIS 16 K, face-to-face dimension FTF EN 558, series 20	J

6 Body material	Code
<b>EN-GJS-400-15 (GGG-40), epoxy coated 250 µm</b>	<b>2</b>
EN-GJS-400-18-LT (GGG-40.3), epoxy coated 250 µm	3

7 Disc material	Code
<b>1.4408/ASTM A351 CF8M</b>	<b>A</b>
1.4408, polished, roughness Ra 0.6–3.2, except disc marking	B
<b>1.4408, HALAR coated</b>	<b>C</b>
<b>1.4469/ASTM GR5A</b>	<b>D</b>
EN-GJS-400-15 (GGG-40), epoxy coated	E
EN-GJS-400-15 (GGG-40), HALAR coated	P
<b>EN-GJS-400-15 (GGG-40), RILSAN PA11 coated</b>	<b>R</b>
2.0975/CC333G	G
1.4435/ASTM A351/CF3M/AISI 316L	I

8 Shaft material	Code
1.4021/AISI 420	1

9 Shut-off seal material	Code
<b>EPDM</b>	<b>E</b>
SBR-AB/P (abrasion resistant)	F
CSM	H
NR (FDA/1935-2004 certification), white AB/W	I
NBR (DVGW Gas certification)	J
EPDM (FDA/1935-2004 certification), white	M
<b>NBR</b>	<b>N</b>
FKM +	O
EPDM-SHT (steam)	T
NBR (FDA/1935-2004 certification), white	U
<b>FKM</b>	<b>V</b>
<b>EPDM (drinking water compliant)</b>	<b>W</b>
<b>EPDM-HT (FDA/1935-2004 certification)</b>	<b>Z</b>

Order data

10 Liner fixing	Code
Liner bonded into body	B
Loose liner	L

11 Type of design	Code
Without	
Media-wetted area cleaned to ensure suitability for paint applications, parts sealed in plastic bag	0101
Valve free of oil and grease, media-wetted area cleaned and packed in PE bag	0107
Stainless steel valve disc, without lettering, mechanically polished to 1.6 µm and electropolished, spigot internally polished to 1.6 µm, no polishing of internal threads	1782
Butterfly valve body powder coated, RAL 5015, sky blue	1892
Butterfly valve body powder coated, RAL 1023, traffic yellow	1925
Mounting parts in A4 quality. Caution! Danger of galling! Customer must take the necessary precautions for this!	5143
Thermal separation between actuator and valve body via mounting kit	5222
Thermal separation between actuator and valve body via dew point barrier	5226
Aluminium product label, black anodized, lasered marking, riveted to the body	6061
Gearbox prepared for limit switch mounting	7042
Gearbox with padlock system	7044

12 Special version	Code
Without	
ACS certification	A
BELGAQUA certification	B
DVGW Water certification	D
Country of origin Germany	E
DVGW Gas certification	G
NSF 61 Water certification	N
Special version for oxygen Maximum temperature for medium: 100 °C, Operating pressure limited in accordance with product label data Media-wetted materials cleaned, and grease and seal tested in accordance with DIN EN 1797/ISO 21010	O
ASME B31.3	P
DNV GL certification	S
WRAS certification	W
ATEX certification	X
ATEX certification (in the piping system)	Y

13 Control function	Code
Manually operated	0

14 Actuator version	Code
Hand lever, aluminium	AHL09
Hand lever, aluminium	AHL11
Hand lever, aluminium	AHL14

14 Actuator version	Code
Hand lever, aluminium	AHL17
Hand lever, aluminium	AHL22
Hand lever, aluminium, continuous	SAHL09
Hand lever, aluminium, continuous	SAHL11
Hand lever, aluminium, continuous	SAHL14
Hand lever, aluminium, continuous	SAHL17
Hand lever, 10 latch positions, diagonal square, WAF = 14 mm	VHL14
Hand lever, 10° latch positions, diagonal square, WAF = 17 mm	VHL17
Hand lever, 10 notched positions, diagonal square, WAF = 22 mm	VHL22
Gearbox, die-cast aluminium casing	GB232

15 CONEXO	Code
Without	
Integrated RFID chip for electronic identification and traceability	C

**Order example - standard version**

Ordering option	Code	Description
1 Type	R487	Butterfly valve, manually operated, body with C5-M coating (min. 250 µm) and integrated leakage groove, blow-out proof shaft with dust protection, multiple bearings through PTFE bushing, multiple sealing system with insertion slope, material easy to read when installed
2 DN	80	DN 80
3 Body configuration	W	Wafer-type flange design, face-to-face dimension FTF EN 558 series 20
4 Operating pressure	3	16 bar
5 Connection type	3	PN 16/flange EN 1092, face-to-face dimension FTF EN 558 series 20
6 Body material	2	EN-GJS-400-15 (GGG-40), epoxy coated 250 µm
7 Disc material	A	1.4408/ASTM A351 CF8M
8 Shaft material	1	1.4021/AISI 420
9 Shut-off seal material	E	EPDM
10 Liner fixing	L	Loose liner
11 Type of design		Without
12 Special version		Without
13 Control function	0	Manually operated
14 Actuator version	AHL11	Hand lever, aluminium
15 CONEXO		Without

## Technical data

### Medium

**Working medium:** Gaseous and liquid media which have no negative impact on the physical and chemical properties of the disc and seat material.  
 For special version for oxygen (code O): Only gaseous oxygen.

### Temperature

**Media temperature:** -10 – 160 °C  
 Depending on the liner and disc material or the type of liner fixing

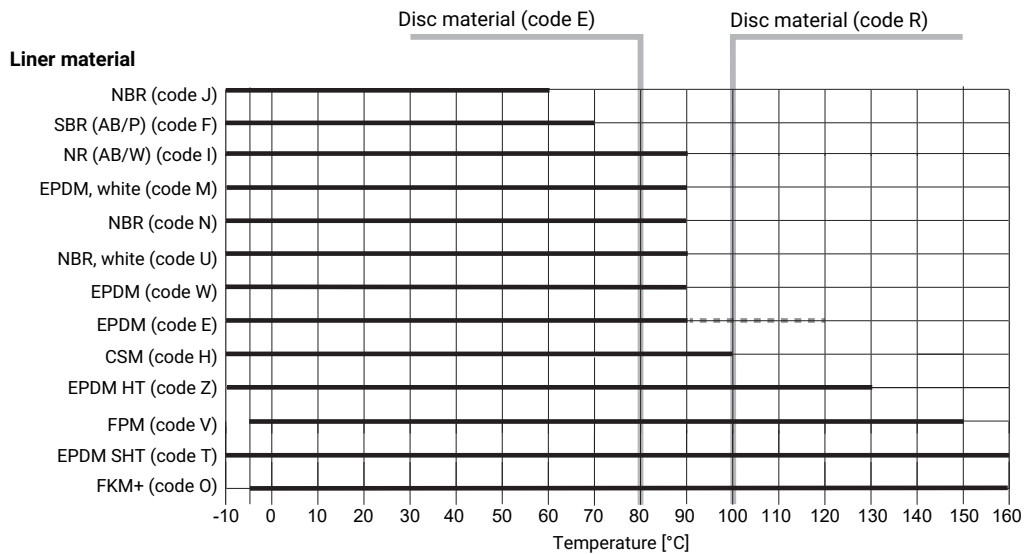

..... Not recommended for permanent temperature

FKM material not suitable for water/steam applications above 100 °C, Observe Pressure/Temperature diagram.

FKM material not suitable for water/steam applications above 100 °C, Observe Pressure/Temperature diagram.

For the medium gaseous oxygen (special version code O): Media temperature max. 100 °C.

**Ambient temperature:** -10 – 70 °C

**Storage temperature:** -20 – 40 °C

### Pressure

**Operating pressure:** DN 25–200: 0–16 bar  
 DN 250–600: 0–10 bar  
 Observe pressure/temperature diagram

Use as an end-of-line valve:

DN 25–200: 10 bar  
 DN 250–600: 6 bar

For the medium gaseous oxygen (special version code O): Operating pressure limited in accordance with product label data.

**Vacuum:** Can be used up to a vacuum of 800 mbar (abs) with replaceable liner or with bonded liner up to a vacuum of 2 mbar (abs) through a leakage rate at 10<sup>-3</sup> [mbar l/sec]  
 These values apply to room temperature and air. The values may deviate for other media and other temperatures.

**Pressure/temperature diagram:**

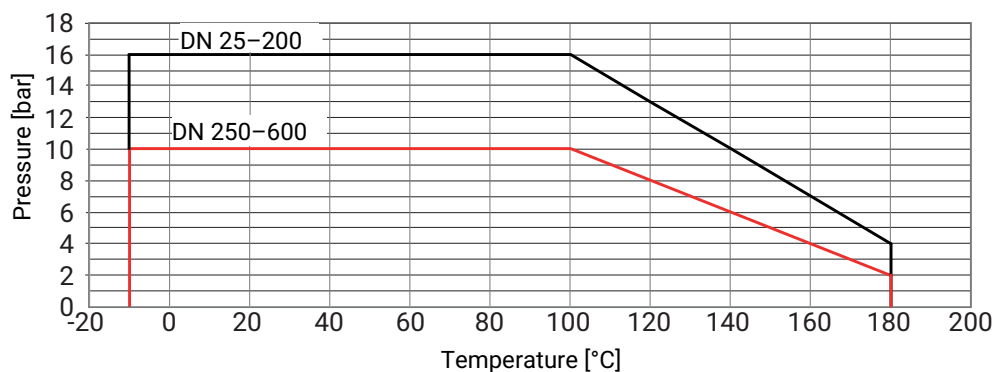

**Pressure rating:**

- PN 3
- PN 6
- PN 10
- PN 16

**Kv values:**

DN	PS [bar]	Cv values at opening angle							
		20°	30°	40°	50°	60°	70°	80°	90°
25	16	0.7	2.0	4.1	7.2	11.0	14.5	16.6	17.2
40	16	2.5	7.0	14.4	25.1	38.3	50.6	57.8	60.0
50	16	3.0	9.0	20.0	33.0	65.0	110.0	124.0	125.0
65	16	9.0	15.0	30.0	64.0	118.0	195.0	214.0	222.0
80	16	19.0	40.0	66.0	117.0	196.0	321.0	353.0	363.0
100	16	29.0	75.0	137.0	213.0	316.0	487.0	584.0	618.0
125	16	48.0	100.0	185.0	315.0	550.0	895.0	1060.0	1120.0
150	16	60.0	150.0	281.0	450.0	789.0	1280.0	1630.0	1730.0
200	3 / 16	110.0	281.0	472.0	759.0	1480.0	2880.0	3710.0	3900.0
250	3 / 10	200.0	444.0	738.0	1190.0	2110.0	3880.0	5180.0	5410.0
300	3 / 10	250.0	682.0	1060.0	1670.0	3120.0	6360.0	8620.0	8930.0
350	3 / 10	322.0	672.0	1180.0	1960.0	3230.0	5230.0	7980.0	9490.0
400	3 / 10	360.0	823.0	1510.0	2560.0	4180.0	6820.0	10700.0	12800.0
450	3 / 10	459.0	1040.0	1900.0	3220.0	5280.0	8680.0	14100.0	17500.0
500	3 / 10	530.0	1230.0	2290.0	3890.0	6430.0	10600.0	17200.0	21800.0
600	3 / 10	767.0	1770.0	3290.0	5610.0	9330.0	15600.0	25800.0	31600.0

Kv values in m³/h

When the opening angle is below 30° no regulation should be made!

## Product conformity

**Pressure equipment standards:** ASME GEMÜ B31.3  
2014/68/EU

The butterfly valve fulfils the technical requirements of pressure equipment categories I and II and can be used under the following conditions.

Areas of use for R487 butterfly valve as in-line valve (classification as per Pressure Equipment Directive 2014/68/EC Article 4 and Annex II)				
	Media of fluid group 1 (dangerous)		Media of fluid group 2 (other)	
PS	Gases (Section 4 (1) c) i), diagram 6)	Liquids (Section 4 (1) c) ii), diagram 8)	Gases (Section 4 (1) c) i), diagram 7)	Liquids (Section 4 (1) c) ii), diagram 9)
<b>16</b>	DN25 – DN200	DN25 – DN200*	DN25 – DN200*	DN25 – DN200*
<b>10</b>	DN25 – DN350	DN25 – DN600	DN25 – DN500	DN25 – DN600
<b>6</b>	DN25 – DN350	DN25 – DN600	DN25 – DN600	DN25 – DN600
<b>3</b>	DN25 – DN350	DN25 – DN600	DN25 – DN600	DN25 – DN600

\* Limit of the technical specification

When used as an end-of-line valve, a mating flange must be fitted.

Special conditions of use as an end-of-line valve: See section 7.3.

**Food:** FDA  
Regulation (EC) No. 1935/2004



**Drinking water:** DVGW  
ACS  
WRAS  
Belgaqua  
NSF



**Oxygen:** Testing of the seal material based on DIN EN 1797 and ISO 21010:2017 (special version code O)

**Gas:** DVGW

**Ship approval:** DNV GL

**Explosion protection:** ATEX (2014/34/EU), order code Special version X and Y

**ATEX marking:** Special function code X  
Gas:  II -/2 G Ex h -/IIB T6...T3 -/Gb X  
Dust:  II -/2D Ex h -/IIIC T150°C -/Db X

Special function code Y  
Gas:  II 2 G Ex h IIC/IIB T6 ... T3 Gb X  
Dust:  II 2 D Ex h IIIC T150 °C Db X

**TA Luft (German Clean Air Act):** The product meets the following requirements under the max. permissible operating conditions:

- Tightness or compliance with the specific leak rate within the sense of TA-Luft as well as VDI 2440
- Compliance with the requirements in accordance with DIN EN ISO 15848-1, Table C.2, Class BH

**Mechanical data**

**Torques:**

DN	PS			
	3 bar	6 bar	10 bar	16 bar*
25	-	-	-	4.0
40	-	-	-	7.0
50	3.0	5.0	7.0	9.0
65	8.0	10.0	13.0	15.0
80	10.0	15.0	20.0	25.0
100	15.0	20.0	30.0	40.0
125	25.0	35.0	45.0	60.0
150	40.0	50.0	80.0	100.0
200	100.0	-	-	160.0
250	140.0	-	200.0	-
300	200.0	-	330.0	-
350	255.0	-	430.0	-
400	580.0	-	1035.0	-
450	600.0	-	1150.0	-
500	860.0	-	1250.0	-
600	1441.0	-	2140.0	-

\* Standard

Torques in Nm

Working medium water (20 °C) and optimal operating conditions

**Weight:**

**Butterfly valve**

DN	Wafer	Lug	U section
25	1.2	-	-
40	1.5	-	-
50	1.7	2.2	-
65	2.5	2.9	-
80	3.2	4.4	-
100	4.4	6.2	-
125	5.9	8.1	-
150	7.7	10.1	-
200	13.9	18.4	-
250	19.6	28.7	-
300	27.3	36.8	-
350	48.0	66.0	-
400	72.0	110.0	107.0
450	95.0	-	125.0
500	120.0	-	164.0
600	192.0	-	261.0

Weights in kg

**Manual actuator**

DN	Designation	Weight
25 – 50	AHL09, SAHL09	0.314
65, 80	AHL11, SAHL11	0.314
100	AHL14, SAHL14	0.314
125, 150	AHL17, SAHL17	0.716
200, 250	AHL22	0.73
50 – 100	VHL14	0.7
125, 150	VHL17	1.2
200	VHL22	2.1
25 – 100	GB 232	0.8
125, 150	GB 232	0.9
200 – 300	GB 232	1.4
350, 400	GB 232	4.7
450, 500	GB880N	14.0
600	GB1250N	22.0

Weights in kg

## Dimensions

### Actuator dimensions

#### Hand lever

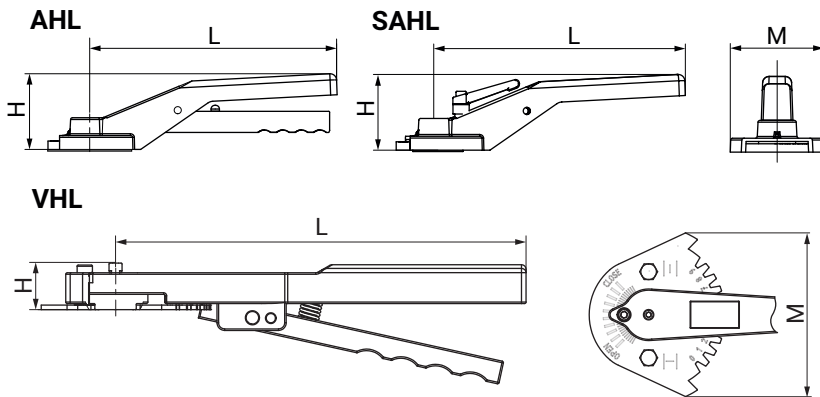

DN	Code	H	L	M
25 - 100	AHL09, AHL11, AHL14	68.0	200.0	72.0
	SAHL09, SAHL11, SAHL14	75.0	200.0	72.0
	VHL14	25.0	195.0	107.0
125, 150	AHL17, SAHL17	90.0	270.0	100.0
	VHL17	29.0	267.0	133.0
200	VHL22	33.0	330.0	191.0
200 - 300	AHL22	75.0	340.0	126.0

Dimensions in mm

**Handwheel with gearbox**

**GB 232**

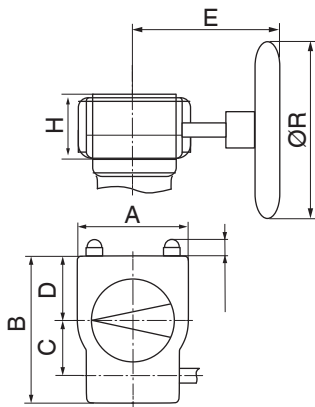

**GB 880N  
GB 1250N**

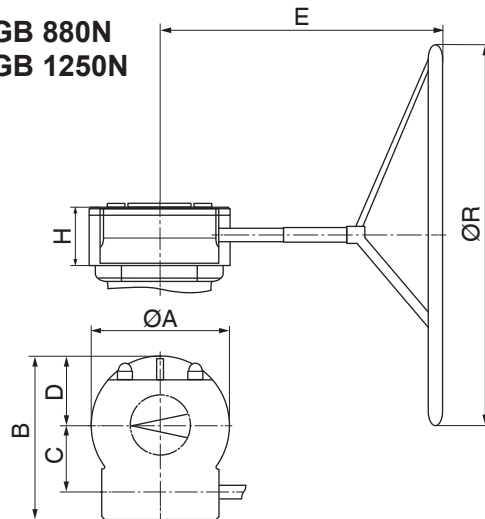

Code	DN	A	B	C	D	E	H	ØR
<b>GB 232</b>	<b>25 – 100</b>	80.0	114.0	42.5	48.0	121.0	53.0	100.0
	<b>125</b>	80.0	114.0	42.5	48.0	171.0	59.0	100.0
	<b>150</b>	80.0	114.0	42.5	48.0	171.0	59.0	160.0
	<b>200 – 300</b>	100.0	131.0	50.0	56.0	195.0	67.0	200.0
	<b>350</b>	175.0	209.0	80.0	83.0	293.0	85.0	500.0
	<b>400</b>	175.0	209.0	80.0	83.0	376.0	85.0	500.0
<b>GB880N</b>	<b>450, 500</b>	200.0	226.0	86.0	100.0	465.0	93.0	800.0
<b>GB1250N</b>	<b>600</b>	220.0	258.0	105.0	110.0	480.0	102.0	700.0

Dimensions in mm

**Body dimensions**

**Actuator flange**

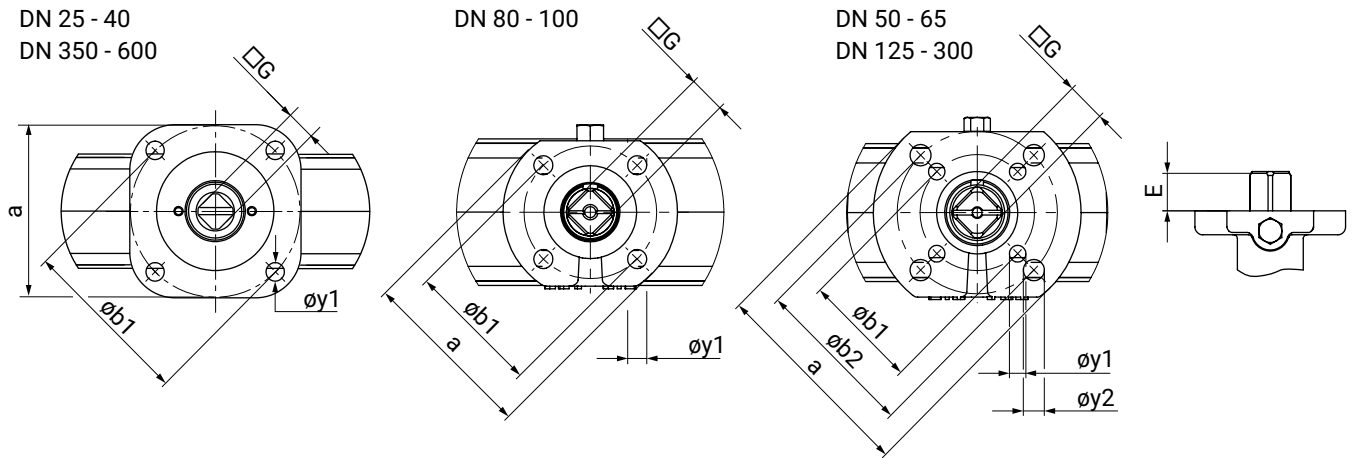

DN	ISO 5211	a	øb1	øy1	øb2	øy2	E		□G		Code
							PS3	PS10/PS16	PS3	PS10/PS16	
25	F05	□50.0	50.0	7.0	-	-	-	19.0	-	9.0	05 D09
32	F05	□50.0	50.0	7.0	-	-	-	19.0	-	9.0	05 D09
40	F05	□50.0	50.0	7.0	-	-	-	19.0	-	9.0	05 D09
50	F03   F05	ø65.0	36.0	6.0	50.0	7.0	-	19.0	-	9.0	05 D09
65	F03   F05	ø65.0	36.0	6.0	50.0	7.0	-	19.0	-	11.0	05 D11
80	F05	ø65.0	50.0	7.0	-	-	-	19.0	-	11.0	05 D11
100	F05	ø65.0	50.0	7.0	-	-	-	19.0	-	14.0	05 D14
125	F05   F07	ø90.0	50.0	7.0	70.0	9.0	-	25.0	-	17.0	07 D17
150	F05   F07	ø90.0	50.0	7.0	70.0	9.0	-	25.0	-	17.0	07 D17
200	F07   F10	ø125.0	70.0	9.0	102.0	11.0	17.0*	32.0	17.0*	22.0	10 D22
250	F07   F10	ø125.0	70.0	9.0	102.0	11.0	17.0*	32.0	17.0*	22.0	10 D22
300	F07   F10	ø125.0	70.0	9.0	102.0	11.0	17.0*	32.0	17.0*	22.0	10 D22
350	F12	□130.0	125.0	13.0	-	-	22.0*	28.0	22.0*	27.0	12 D27
400	F14	□160.0	140.0	17.0	-	-	27.0*	37.0	27.0*	36.0	14 D36
450	F14	□160.0	140.0	17.0	-	-	27.0*	37.0	27.0*	36.0	14 D36
500	F14	□160.0	140.0	17.0	-	-	27.0*	37.0	27.0*	36.0	14 D36
600	F16	□200.0	165.0	21.0	-	-	36.0*	47.0	36.0*	46.0	16 D46

Dimensions in mm

**Body**

**Wafer body configuration**

DN 25 - 100

DN 125 - 600

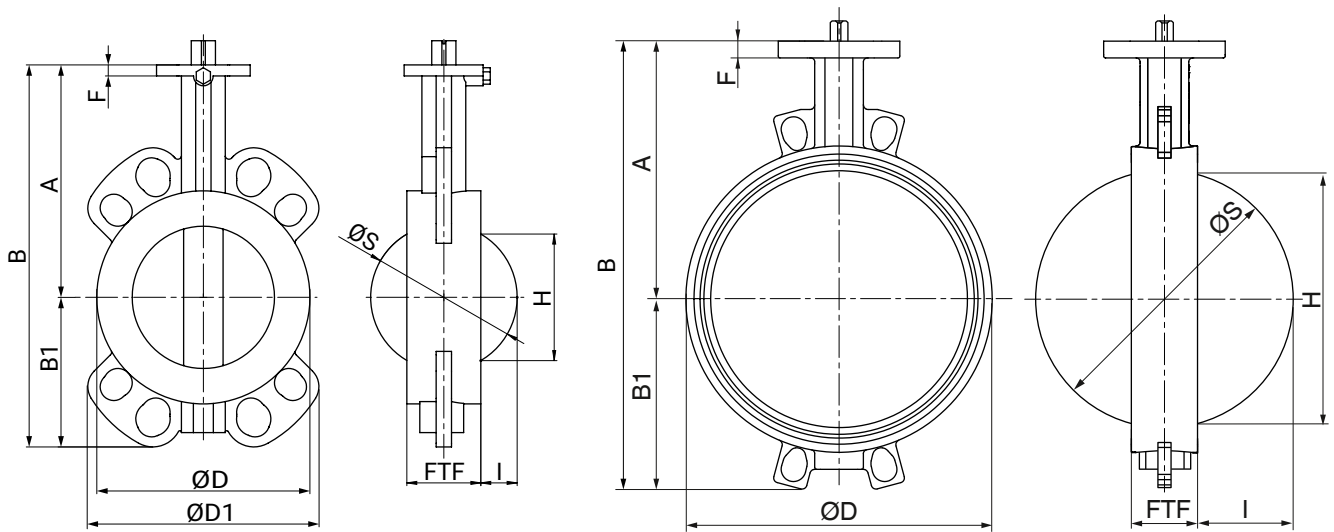

DN	A	B	B1	ØD	ØD1	F	FTF	H*	ØS	I
25	100.0	141.3	41.3	59.5	88.6	12.0	25.0	16.0	26.5	0.5
32	120.0	173.8	53.8	75.8	109.8	12.0	33.0	24.5	41.5	4.0
40	120.0	176.0	56.0	73.0	111.0	12.0	33.0	24.0	41.0	4.0
50	120.0	182.0	62.0	90.0	118.0	12.0	43.0	29.0	52.0	5.0
65	137.0	218.0	81.0	108.0	133.0	12.0	46.0	48.0	67.0	10.0
80	145.0	231.0	87.0	130.0	141.0	12.0	46.0	68.0	82.0	18.0
100	166.0	271.0	105.0	150.0	163.0	14.0	52.0	88.0	102.0	25.0
125	187.0	304.0	117.0	175.0	120.0	16.0	56.0	114.0	127.0	35.0
150	200.0	332.0	132.0	207.0	129.0	16.0	56.0	141.0	152.0	48.0
200	240.0	413.0	173.0	263.0	157.0	17.0	60.0	193.0	202.0	71.0
250	265.0	466.0	201.0	317.0	185.0	17.0	68.0	242.0	252.0	92.0
300	290.0	531.0	241.0	366.0	164.0	17.0	78.0	291.0	302.0	112.0
350	321.0	587.0	266.0	440.0	440.0	15.0	78.0	329.0	337.4	130.0
400	347.0	655.0	308.0	485.0	485.0	20.0	102.0	379.0	391.4	145.0
450	372.0	705.0	333.0	541.0	541.0	20.0	144.0	428.0	441.4	164.0
500	398.0	756.0	358.0	600.0	600.0	20.0	127.0	478.0	493.4	183.5
600	470.0	912.0	442.0	700.0	700.0	24.0	154.0	574.0	593.4	220.0

Dimensions in mm

\* Please note dimension H to prevent disc binding on internal pipe

Please note: chamfer flanges for plastic pipelines if necessary

**Threaded hole**

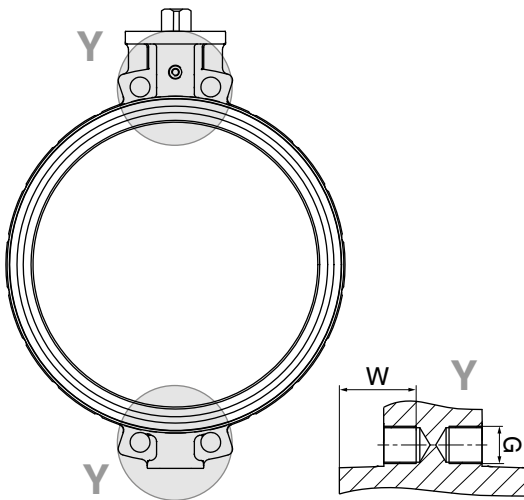

**Threaded hole (detail Y)**

DN	Connection type code <sup>1)</sup>					
	2		3		D	
	G	W	G	W	G	W
<b>450</b>	M24	46	M27	46	Ø 31,7	-

Dimensions in mm

**1) Connection type**

Code 2: PN 10/flange EN 1092, face-to-face dimension FTF EN 558 series 20

Code 3: PN 16/flange EN 1092, face-to-face dimension FTF EN 558 series 20

Code D: ANSI B16.5, class 150, face-to-face dimension FTF EN 558, series 20, For lug bodies/threaded holes with UNC thread

**Connections**

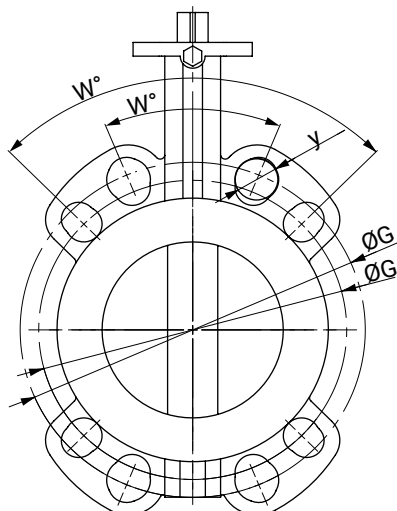

**Connection EN1092, ANSI B16.5**

DN	INCH	Connection (code)															
		EN1092-1 PN6 (code 1)				EN1092-1 PN10 (code 2)				EN1092-1 PN16 (code 3)				ANSI B16.5/CL150 (code D)			
DIN	ANSI	w°	n	ØG	y	w°	n	ØG	y	w°	n	ØG	y	w°	n	ØG	y
25	1"	90.0	4	75.0	M10	90.0	4	85.0	M12	90.0	4	85.0	M12	90.0	4	79.0	1/2"
32	1¼"	90.0	4	90.0	M12	90.0	4	100.0	M16	90.0	4	100.0	M16	90.0	4	89.0	1/2"
40	1½"	90.0	4	100.0	M12	90.0	4	110.0	M16	90.0	4	110.0	M16	90.0	4	98.0	1/2"
50	2"	90.0	4	110.0	M12	90.0	4	125.0	M16	90.0	4	125.0	M16	90.0	4	121.0	5/8"
65	2½"	90.0	4	130.0	M12	45.0	8	145.0	M16	90.0	8	145.0	M16	90.0	4	140.0	5/8"
80	3"	90.0	4	150.0	M16	45.0	8	160.0	M16	45.0	8	160.0	M16	90.0	4	152.0	5/8"
100	4"	90.0	4	170.0	M16	45.0	8	180.0	M16	45.0	8	180.0	M16	45.0	8	191.0	5/8"
125	5"	45.0	8	200.0	M16	45.0	8	210.0	M16	45.0	8	210.0	M16	45.0	8	216.0	3/4"
150	6"	45.0	8	225.0	M16	45.0	8	240.0	M20	45.0	8	240.0	M20	45.0	8	241.0	3/4"
200	8"	45.0	8	280.0	M16	45.0	8	295.0	M20	30.0	12	295.0	M20	45.0	8	298.0	3/4"
250	10"	30.0	12	335.0	M16	30.0	12	350.0	M20	30.0	12	355.0	M24	30.0	12	362.0	7/8"
300	12"	30.0	12	395.0	M20	30.0	12	400.0	M20	30.0	12	410.0	M24	30.0	12	432.0	7/8"
350	14"	-	-	-	-	22.5	16	460.0	M20	22.5	16	470.0	M24	30.0	12	476.0	1"
400	16"	-	-	-	-	22.5	16	515.0	M24	22.5	16	525.0	M27	22.5	16	540.0	1"
450	18"	-	-	-	-	18.0	20	565.0	M24	18.0	20	585.0	M27	22.5	16	578.0	1½"
500	20"	-	-	-	-	18.0	20	620.0	M24	18.0	20	650.0	M30	18.0	20	635.0	1½"
600	24"	-	-	-	-	18.0	20	725.0	M27	18.0	20	770.0	M33	18.0	20	749.0	1¼"

Dimensions in mm  
n = number of bolts

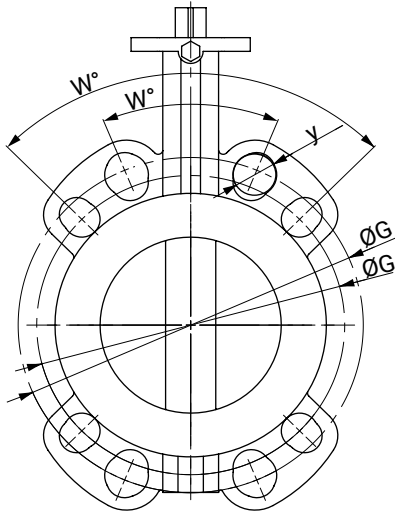

**Connection AS2129, BS10**

DN	INCH	Connection (code)															
		AS 2129 D (code T)				AS 2129 E (code U)				BS10 D (code H)				BS10 E (code S)			
DIN	ANSI	w°	n	ØG	y	w°	n	ØG	y	w°	n	ØG	y	w°	n	ØG	y
25	1"	90.0	4	83.0	M12	90.0	4	83.0	M12	90.0	4	83.0	M12	90.0	4	83.0	M12
32	1¼"	90.0	4	87.0	M12	90.0	4	87.0	M12	90.0	4	87.0	M12	90.0	4	87.0	M12
40	1½"	90.0	4	98.0	M12	90.0	4	98.0	M12	90.0	4	98.0	M12	90.0	4	98.0	M12
50	2"	90.0	4	114.0	M16	90.0	4	114.0	M16	90.0	4	114.0	M16	90.0	4	114.0	M16
65	2½"	90.0	4	127.0	M16	90.0	4	127.0	M16	90.0	4	127.0	M16	90.0	4	127.0	M16
80	3"	90.0	4	146.0	M16	90.0	4	146.0	M16	90.0	4	146.0	M16	90.0	4	146.0	M16
100	4"	90.0	4	178.0	M16	45.0	8	178.0	M16	90.0	4	178.0	M16	45.0	8	178.0	M16
125	5"	45.0	8	210.0	M16	45.0	8	210.0	M16	45.0	8	210.0	M16	45.0	8	210.0	M16
150	6"	45.0	8	235.0	M16	45.0	8	235.0	M20	45.0	8	235.0	M16	45.0	8	235.0	M20
200	8"	45.0	8	292.0	M16	45.0	8	292.0	M20	45.0	8	292.0	M16	45.0	8	292.0	M20
250	10"	45.0	8	356.0	M20	30.0	12	356.0	M20	45.0	8	356.0	M20	30.0	12	356.0	M20
300	12"	30.0	12	406.0	M20	30.0	12	406.0	M22	30.0	12	406.0	M20	30.0	12	406.0	M22
350	14"	30.0	12	470.0	M22	30.0	12	470.0	M27	30.0	12	470.0	M22	30.0	12	470.0	M27
400	16"	-	-	-	-	-	-	-	-	-	-	-	-	-	-	-	-
450	18"	-	-	-	-	22.5	16	584.0	M24	-	-	-	-	22.5	16	584.0	M24
500	20"	-	-	-	-	-	-	-	-	-	-	-	-	-	-	-	-
600	24"	22.5	16	756.0	M27	22.5	16	756.0	M30	22.5	16	756.0	M27	22.5	16	756.0	M30

Dimensions in mm  
n = number of bolts

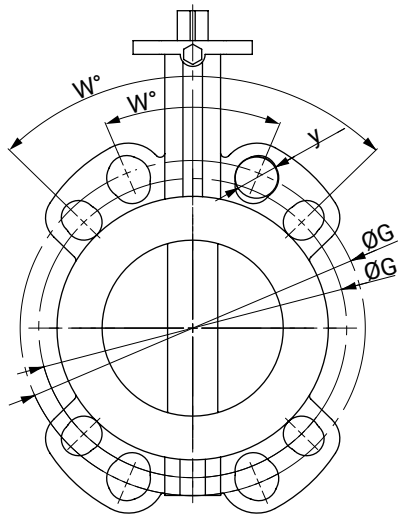

**Connection JIS K10, K16**

DN	INCH	Connection (code)							
		JIS-K10 (code G)				JIS-K16 (code J)			
DIN	ANSI	$w^\circ$	n	$\text{ØG}$	y	$w^\circ$	n	$\text{ØG}$	y
25	1"	90	4	90.0	M16	90	4	90.0	M16
32	1¼"	90	4	100.0	M16	90	4	100.0	M16
40	1½"	90	4	105.0	M16	90	4	105.0	M16
50	2"	90.0	4	120.0	M16	45.0	8	120.0	M16
65	2½"	90.0	4	140.0	M16	45.0	8	140.0	M16
80	3"	45.0	8	150.0	M16	45.0	8	160.0	M20
100	4"	45.0	8	175.0	M16	45.0	8	185.0	M20
125	5"	45.0	8	210.0	M20	-	-	-	-
150	6"	45.0	8	240.0	M20	-	-	-	-
200	8"	30.0	12	290.0	M20	30.0	12	305.0	M24
250	10"	30.0	12	355.0	M24	-	-	-	-
300	12"	22.5	16	400.0	M24	-	-	-	-
350	14"	-	-	-	-	-	-	-	-
400	16"	22.5	16	510.0	M24	-	-	-	-
450	18"	18	20	565.0	M24	-	-	-	-
500	20"	18	20	620.0	M24	-	-	-	-
600	24"	15	24	730.0	M30	-	-	-	-

Dimensions in mm  
n = number of bolts

## Availabilities

Flange	Wafer																	
	25	32	40	50	65	80	100	125	150	200	250	300	350	400	450	500	600	
EN1092-1 PN6	1	1	1	1	1	1	1	1	1	1	1	1	-	-	-	-	-	
EN1092-1 PN10	2	2	2	2	2	2	2	2	2	2	2	2	2	2	2	2	2	
EN1092-1 PN16	3	3	3	3	3	3	3	3	3	3	3	3	3	3	3	3	3	
ANSI B16.5/CL150	D	D	D	D	D	D	D	D	D	D	D	D	D	D	D	D	D	
AS 2129 D	T	T	T	T	T	T	T	T	T	T	T	T	T	T	-	-	-	T
AS 2129 E	U	U	U	U	U	U	U	U	U	U	U	U	U	U	-	U	-	U
JIS 5 K	K	K	K	-	K	K	-	K	K	K	K	-	-	-	-	-	-	
JIS-K10	G	G	G	G	G	G	G	G	G	G	G	G	G	-	G	G	G	G
JIS-K16	J	J	J	J	J	J	J	-	-	J	-	-	-	-	-	-	-	
BS10 D	H	H	H	H	H	H	H	H	H*	H*	H	H*	H	-	-	-	H	
BS10 E	S	S	S	S	S	S	S	S	S	S*	S*	S	S	-	S	-	S	

\* Note: It is important to centrally align the butterfly valve during installation

**Connection – screws, bolts**

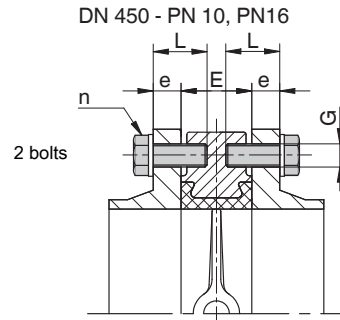
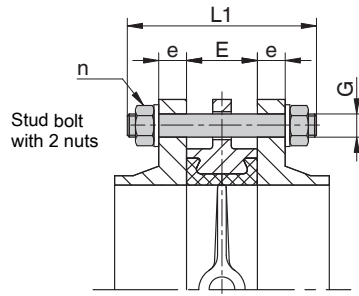
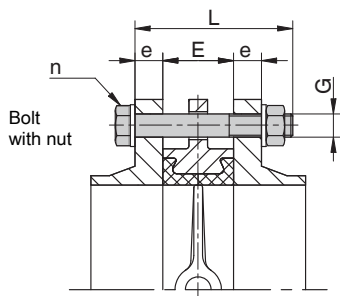

n = number of bolts  
 n/2 = number of eyes (flange eyes)

DN	E	Connection (code)									
		EN1092-1 PN10 (code 2)					EN1092-1 PN16 (code 3)				
		e	L	L1	n	G	e	L	L1	n	G
25	25	18	85	100	4	M12	18	85	100	4	M12
32	33	18	90	110	4	M12	18	90	110	4	M16
40	33	18	90	110	4	M12	18	90	110	4	M16
50	43	18	100	120	4	M16	18	100	120	4	M16
65	46	18	100	120	4	M16	18	100	120	4	M16
80	46	20	110	130	8	M16	20	110	130	8	M16
100	52	20	110	130	8	M16	20	110	130	8	M16
125	56	22	120	140	8	M16	22	120	140	8	M16
150	56	22	130	150	8	M20	22	130	150	8	M20
200	60	24	130	160	8	M20	24	130	160	12	M20
250	68	26	150	170	12	M20	26	150	170	12	M24
300	78	26	160	180	12	M20	28	160	180	12	M24
350	78	26	170	180	16	M20	30	170	190	16	M24
400	102	26	180	210	16	M24	32	200	220	16	M27
450	114	26	190	220	16	M24	32	210	240	16	M27
	114	26	60	-	8	M24	32	60	-	8	M27
500	127	28	210	230	20	M24	34	230	260	20	M30
600	154	28	240	270	20	M27	36	260	290	20	M33

Dimensions in mm

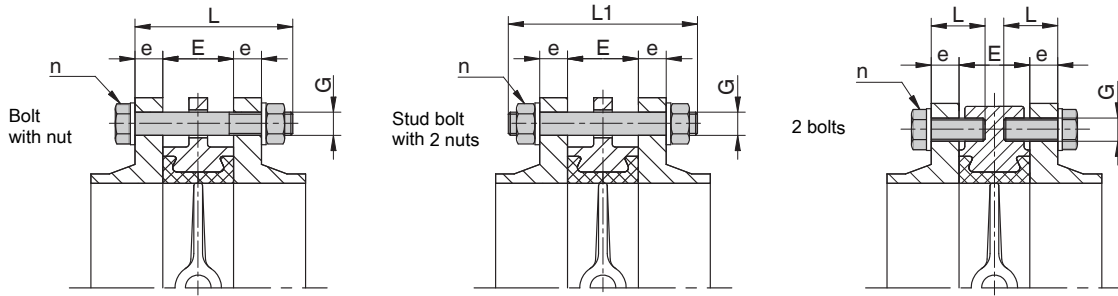

n = number of bolts

n/2 = number of eyes (flange eyes)

DN	E	ANSI B16.5/CL150 (code D)				
		e	L	L1	n	G <sup>1)</sup>
25	25	14.3	85	100	4	1/2"-13
32	33	17.5	90	110	4	1/2"-13
40	33	17.5	90	110	4	1/2"-13
50	43	19.0	100	120	4	5/8"-11
65	46	22.2	110	130	4	5/8"-11
80	46	23.8	110	130	4	5/8"-11
100	52	23.8	120	140	8	5/8"-11
125	56	23.8	130	150	8	3/4"-10
150	56	25.4	130	150	8	3/4"-10
200	60	28.6	140	160	8	3/4"-10
250	68	30.2	160	180	12	7/8"-9
300	78	31.7	170	190	12	7/8"-9
350	78	34.9	180	200	12	1"-8
400	102	36.5	210	230	16	1"-8
450	114	39.7	230	250	16	1 1/8"-7
450	114	39.7	230	250	16	1 1/8"-7
500	127	46.0	250	280	20	1 1/8"-7
600	154	47.6	280	310	20	1 1/4"-7

Dimensions in mm

1) Thread acc. to UNC

**Lug body configuration**

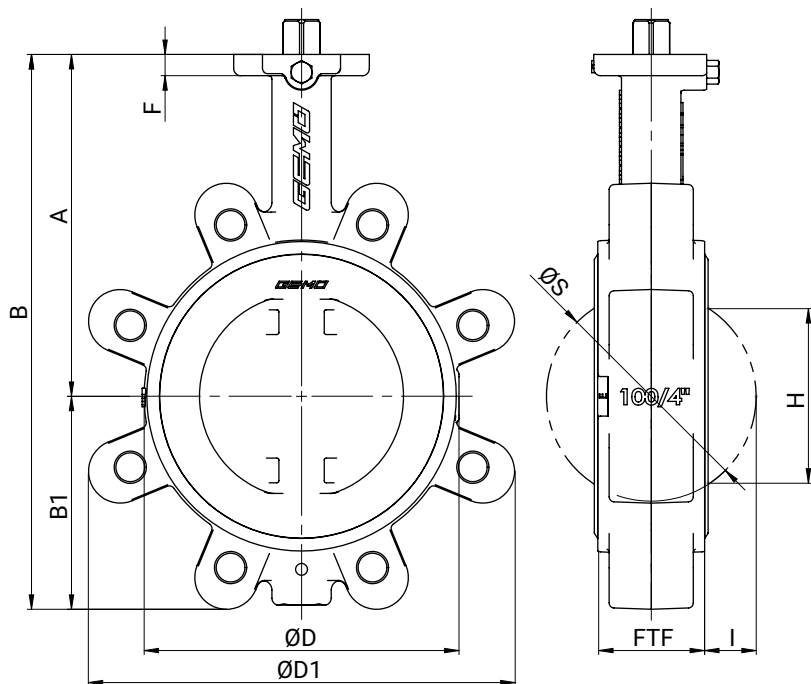

DN	A	B	B1	ØD	ØD1	F	FTF	H*	ØS	I
50	120.0	182.0	62.0	91.0	116.0	12.0	44.0	29.0	52.0	4.0
65	137.0	219.0	82.0	109.0	126.0	12.0	46.0	48.0	67.0	10.0
80	145.0	234.0	89.0	131.0	177.0	12.0	46.0	68.0	82.0	18.0
100	166.0	270.0	104.0	153.0	207.0	14.0	52.0	88.0	102.0	25.0
125	187.0	305.0	118.0	175.0	231.0	16.0	56.0	114.0	127.0	36.0
150	200.0	333.0	133.0	208.0	255.0	16.0	56.0	141.0	152.0	48.0
200	240.0	415.0	175.0	264.0	325.0	17.0	60.0	193.0	202.0	71.0
250	265.0	467.0	202.0	317.0	386.0	17.0	68.0	242.0	252.0	92.0
300	290.0	531.0	241.0	366.0	459.0	17.0	78.0	291.0	302.0	112.0
350	321.0	581.0	260.0	520.0	520.0	15.0	78.0	329.0	337.4	130.0
400	347.0	647.0	300.0	596.0	596.0	20.0	102.0	379.0	391.4	145.0

Dimensions in mm

\* Please note dimension H to prevent disc binding on internal pipe

Please note: chamfer flanges for plastic pipelines if necessary

## Connections

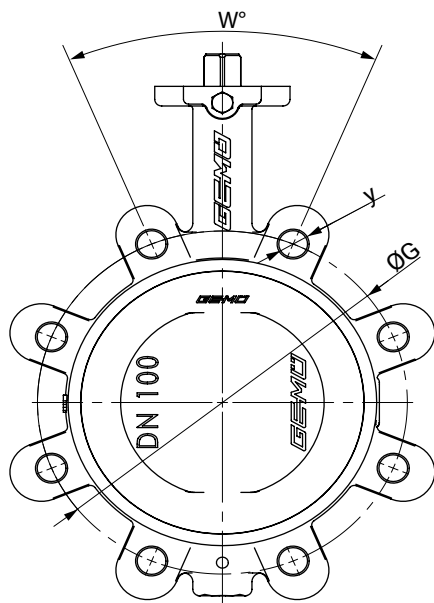

## Connection EN1092, ANSI B16.5

DN	INCH	Connection (code)															
		EN1092-1 PN6 (code 1)				EN1092-1 PN10 (code 2)				EN1092-1 PN16 (code 3)				ANSI B16.5/CL150 (code D)			
DIN	ANSI	w°	n	ØG	y	w°	n	ØG	y	w°	n	ØG	y	w°	n	ØG	y
50	2"	90.0	4	110.0	M12	90.0	4	125.0	M16	90.0	4	125.0	M16	90.0	4	120.6	5/8"
65	2½"	90.0	4	130.0	M12	90.0	4*	145.0	M16	90.0	8*	145.0	M16	90.0	4	139.7	5/8"
80	3"	90.0	4	150.0	M16	45.0	8	160.0	M16	45.0	8	160.0	M16	90.0	4	152.4	5/8"
100	4"	90.0	4	170.0	M16	45.0	8	180.0	M16	45.0	8	180.0	M16	45.0	8	190.5	5/8"
125	5"	45.0	8	200.0	M16	45.0	8	210.0	M16	45.0	8	210.0	M16	45.0	8	215.9	3/4"
150	6"	45.0	8	225.0	M16	45.0	8	240.0	M20	45.0	8	240.0	M20	45.0	8	241.3	3/4"
200	8"	45.0	8	280.0	M16	45.0	8	295.0	M20	30.0	12	295.0	M20	45.0	8	298.5	3/4"
250	10"	30.0	12	335.0	M16	30.0	12	350.0	M20	30.0	12	355.0	M24	30.0	12	362.0	7/8"
300	12"	30.0	12	395.0	M20	30.0	12	400.0	M20	30.0	12	410.0	M24	30.0	12	431.8	7/8"
350	14"	30.0	12	445.0	M20	22.5	16	460.0	M20	22.5	16	470.0	M24	30.0	12	476.0	1"
400	16"	22.5	16	495.0	M20	22.5	16	515.0	M24	22.5	16	525.0	M27	22.5	16	540.0	1"

Dimensions in mm

n = number of bolts

\* Standard: 8 holes code 3 (PN16); if 4 holes are required, select code 2 (PN10);

## Dimensions

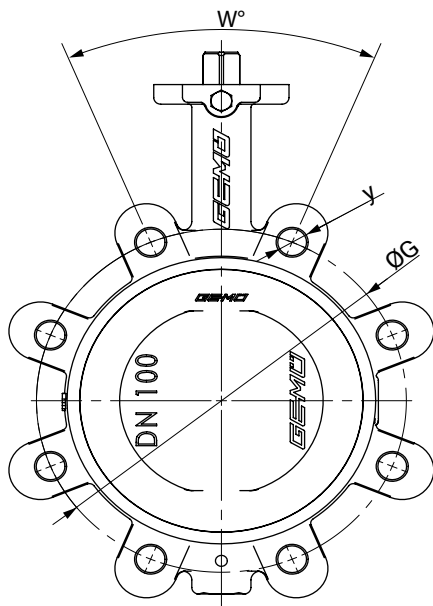

### Connection AS 2129, BS10

DN	INCH	Connection (code)															
		AS 2129 D (code T)				AS 2129 E (code U)				BS10 D (code H)				BS10 E (code S)			
DIN	ANSI	w°	n	ØG	y	w°	n	ØG	y	w°	n	ØG	y	w°	n	ØG	y
50	2"	90.0	4	114.0	M16	90.0	4	114.0	M16	90.0	4	114.3	M16	90.0	4	114.3	M16
65	2½"	90.0	4	127.0	M16	90.0	4	127.0	M16	90.0	4	127.0	M16	90.0	4	127.0	M16
80	3"	90.0	4	146.0	M16	90.0	4	146.0	M16	90.0	4	146.1	M16	90.0	4	146.1	M16
100	4"	90.0	4	178.0	M16	45.0	8	178.0	M16	90.0	4	177.8	M16	45.0	8	177.8	M16
125	5"	45.0	8	210.0	M16	45.0	8	210.0	M16	45.0	8	209.6	M16	45.0	8	209.6	M16
150	6"	45.0	8	235.0	M16	45.0	8	235.0	M20	45.0	8	235.0	M16	45.0	8	235.0	M20
200	8"	45.0	8	292.0	M16	45.0	8	292.0	M20	45.0	8	292.1	M16	45.0	8	292.1	M20
250	10"	45.0	8	356.0	M20	30.0	12	356.0	M20	45.0	8	355.6	M20	30.0	12	355.6	M20
300	12"	30.0	12	406.0	M20	30.0	12	406.0	M22	30.0	12	406.4	M20	30.0	12	406.4	M22
350	14"	30.0	12	470.0	M22	30.0	12	470.0	M27	30.0	12	470.0	M22	30.0	12	470.0	M27

Dimensions in mm  
n = number of bolts

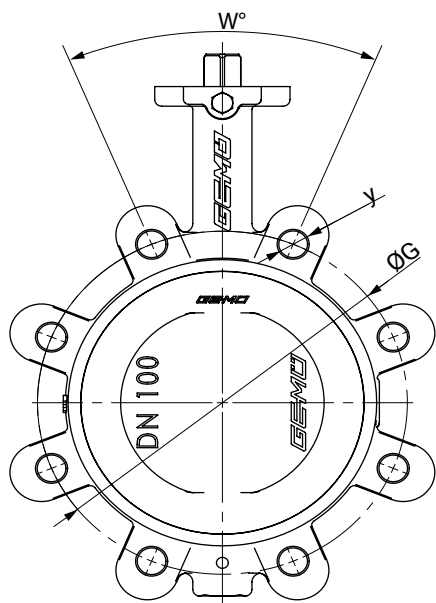

**Connection JIS-K10**

DN	INCH	Connection (code)			
		JIS-K10 (code G)			
DIN	ANSI	w°	n	ØG	y
50	2"	90.0	4	120.0	M16
65	2½"	90.0	4	140.0	M16
80	3"	45.0	8	150.0	M16
100	4"	45.0	8	175.0	M16
125	5"	45.0	8	210.0	M20
150	6"	45.0	8	240.0	M20
200	8"	30.0	12	290.0	M20
250	10"	30.0	12	355.0	M24
300	12"	22.5	16	400.0	M24
350	14"	22.5	16	445.0	M22
400	16"	22.5	16	510.0	M24

Dimensions in mm  
n = number of bolts

**Availabilities**

Flange	Lug										
	50	65	80	100	125	150	200	250	300	350	400
EN1092-1 PN6	1	1	1	1	1	1	1	1	1	-	-
EN1092-1 PN10	3	3*	3	3	3	3	2	2	2	2	2
EN1092-1 PN16	3	3*	3	3	3	3	3	3	3	3	3
ANSI B16.5/CL150	D	D	D	D	D	D	D	D	D	D	D
AS 2129 D	T	-	T	T	T	T	T	-	T	-	-
AS 2129 E	U	-	U	U	U	U	U	U	U	-	-
JIS-K10	G	G	G	G	G	G	G	G	-	G	G
BS10 D	H	-	H	H	H	H	H	-	H	-	-
BS10 E	S	-	S	S	S	S	S	S	S	-	-

\* drilled, with four threaded holes

**Connection – screws, bolts**

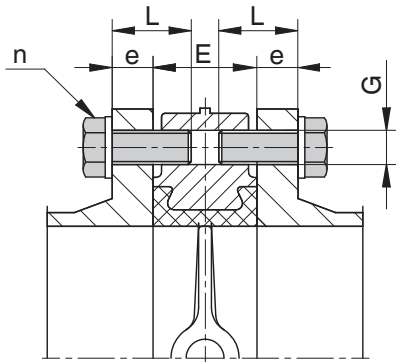

n = number of bolts (thread)

DN	E	Connection (code)											
		EN1092-1 PN10 (code 2)				EN1092-1 PN16 (code 3)				ANSI B16.5/CL150 (code D)			
		e	L	n	G	e	L	n	G	e	L	n	G <sup>1)</sup>
50	43	18	35	8	M16	18	40	8	M16	19	40	8	5/8"-11
65	46	18	40	8	M16	18	40	8	M16	22.2	45	8	5/8"-11
80	46	20	40	16	M16	20	40	16	M16	23.8	45	8	5/8"-11
100	52	20	45	16	M16	20	45	16	M16	23.8	50	16	5/8"-11
125	56	22	45	16	M16	22	45	16	M16	23.8	55	16	3/4"-10
150	56	22	45	16	M20	22	45	16	M20	25.4	55	16	3/4"-10
200	60	24	50	16	M20	24	50	24	M20	28.6	65	16	3/4"-10
250	68	26	55	24	M20	26	55	24	M24	30.2	70	24	7/8"- 9
300	78	26	60	24	M20	28	65	24	M24	31.7	80	24	7/8"- 9
350	78	26	60	32	M20	30	60	32	M24	34.9	75	24	1"- 8
400	102	26	65	32	M24	32	65	32	M27	36.5	85	32	1"- 8

Dimensions in mm

1) Thread acc. to UNC

**U section body configuration**

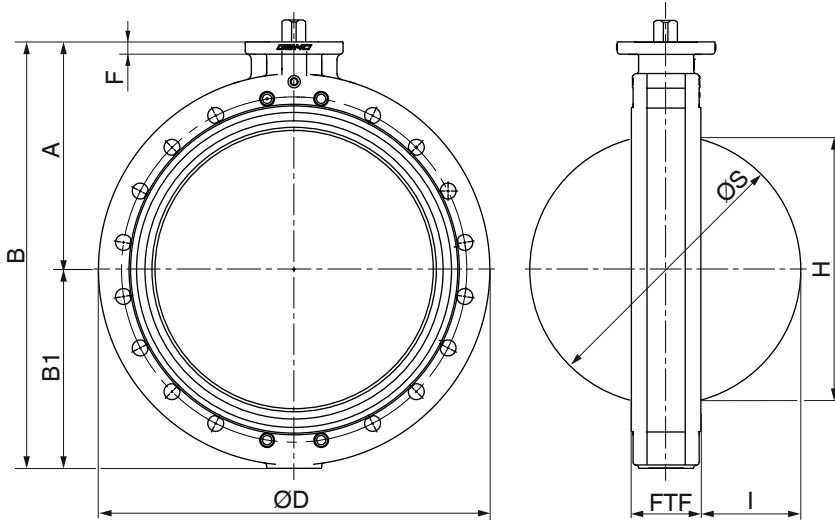

DN	A	B	B1	ØD	F	FTF	H*	I	ØS
400	347.0	662.0	315.0	596.0	20.0	102.0	379.0	145.0	391.4
450	372.0	712.0	340.0	640.0	20.0	114.0	428.0	164.0	441.4
500	398.0	763.0	365.0	715.0	20.0	127.0	478.0	183.5	493.4
600	470.0	917.0	447.0	840.0	24.0	154.0	574.0	220.0	593.4

Dimensions in mm

\* Please note dimension H to prevent disc binding on internal pipe

Please note: chamfer flanges for plastic pipelines if necessary

**Threaded hole**

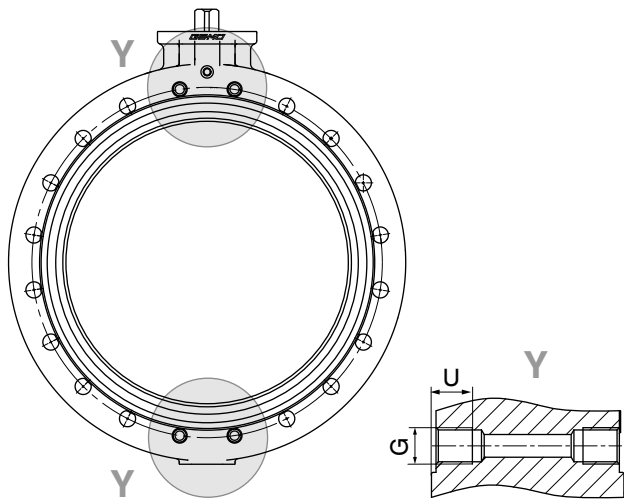

**Threaded hole (detail Y)**

DN	Connection type code <sup>1)</sup>					
	2		3		D	
	G	U	G	U	G <sup>2)</sup>	U
<b>400</b>	M24	24	M27	27	1"-8	-
<b>450</b>	M24	24	M27	27	1 1/8"-7	30
<b>500</b>	M24	24	M30	30	1 1/8"-7	30
<b>600</b>	M27	27	M33	33	1 1/4"-7	33

Dimensions in mm

1) **Connection type**

Code 2: PN 10/flange EN 1092, face-to-face dimension FTF EN 558 series 20

Code 3: PN 16/flange EN 1092, face-to-face dimension FTF EN 558 series 20

Code D: ANSI B16.5, class 150, face-to-face dimension FTF EN 558, series 20, For lug bodies/threaded holes with UNC thread

2) Thread acc. to UNC

**Connections**

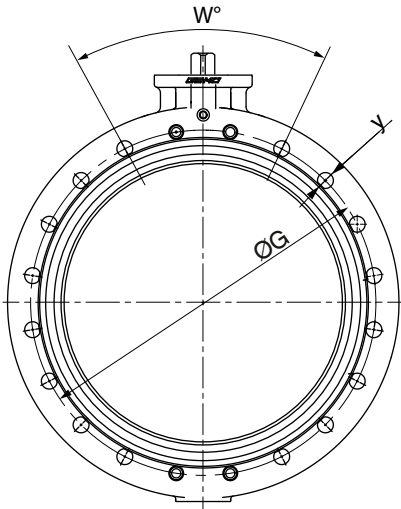

DN	INCH	Connection (code)											
		EN1092-1 PN10 (code 2)				EN1092-1 PN16 (code 3)				ANSI B16.5/CL150 (code D)			
DIN	ANSI	$w^\circ$	n	ØG	y	$w^\circ$	n	ØG	y	$w^\circ$	n	ØG	y
400	16"	22.5	16.0	515.0	M24	22.5	16.0	525.0	M27	22.5	16.0	540.0	1"
450	18"	18.0	20.0	565.0	M24	18.0	20.0	585.0	M27	22.5	16.0	578.0	1½"
500	20"	18.0	20.0	620.0	M24	18.0	20.0	650.0	M30	18.0	20.0	635.0	1½"
600	24"	18.0	20.0	725.0	M27	18.0	20.0	770.0	M33	18.0	20.0	749.0	1¼"

Dimensions in mm

**Availabilities**

Flange	U section			
	400	450	500	600
EN1092-1 PN6	1*	1*	1*	1*
EN1092-1 PN10	2	2	2	2
EN1092-1 PN16	3	3	3	3
ANSI B16.5/CL150	D	D	D	D
AS 2129 E	-	U	-	-
BS10 D	-	-	-	H
BS10 E	-	S	-	-

\* only available with threaded holes

**Connection – screws, bolts**

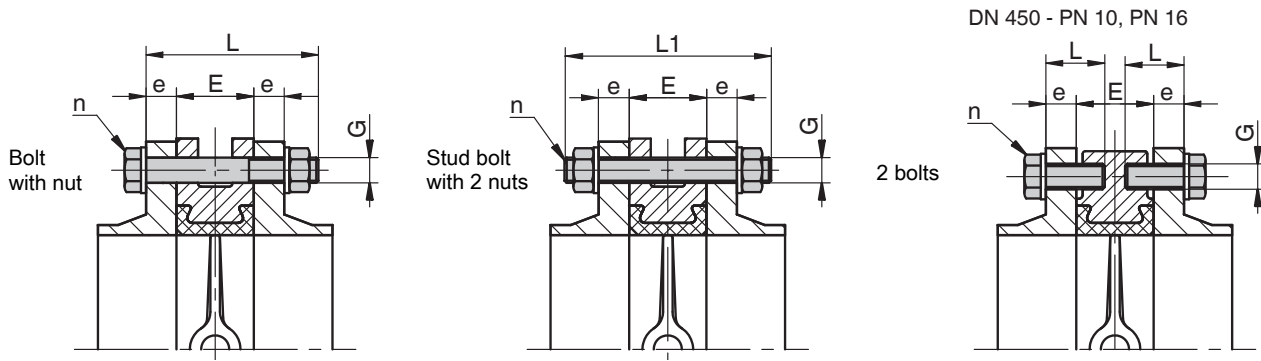

n = number of bolts

DN	E	Connection (code)									
		EN1092-1 PN10 (code 2)					EN1092-1 PN16 (code 3)				
		e	L	L1	n	G	e	L	L1	n	G
400	102	26	180	210	12	M24	32	200	220	12	M27
	102	26	50	210	8	M24	32	55	220	8	M27
450	114	26	190	220	16	M24	32	210	240	16	M27
	114	26	50	220	8	M24	32	55	240	8	M27
500	127	28	210	230	16	M24	34	230	260	16	M30
	127	28	50	230	8	M24	34	60	260	8	M30
600	154	28	240	270	16	M27	36	260	290	16	M33
	154	28	50	270	8	M27	36	60	290	8	M33

Dimensions in mm

DN	E	ANSI B16.5/CL150 (code D)				
		e	L	L1	n	G <sup>1)</sup>
400	102	36.5	210	230	12	1"- 8
	102	36.5	210	230	8	1"- 8
450	114	39.7	230	250	16	1 1/8"-7
	114	39.7	65	250	8	1 1/8"-7
500	127	46.0	250	280	16	1 1/8"-7
	127	46.0	70	280	8	1 1/8"-7
600	154	47.6	280	310	16	1 1/4"-7
	154	47.6	70	310	8	1 1/4"-7

Dimensions in mm

1) Thread acc. to UNC

## Add-on components



### GEMÜ LSC

#### Limit switch box for quarter turn actuators

The GEMÜ LSC limit switch box is suitable for mounting to manually and pneumatically operated quarter turn valves. It is also fitted with an optical position indicator for visual confirmation of position.

## Accessories

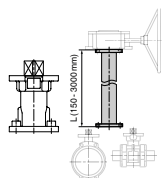

### GEMÜ RC0

#### Shaft extension

The RC0 shaft extension for quarter turn valves is a distance piece between manually, pneumatically or electrically operated valves. This means that valves can be protected from flooding or better access for operation of the valve can be ensured (also for manual override).



### GEMÜ MSC

#### Mounting kit

The MSC mounting kit is an interface, for the same and different ends, to join flange designs according to ISO 5211. This mounting kit ensures thermal separation of actuator and valve body. It can also be used as height compensation for insulated pipelines. The mounting kit is available in steel, electrogalvanized and stainless steel in an open or closed design.

### GEMÜ ADH

#### Mounting sleeve

The mounting sleeve accessories are available in the square and star geometry designs. These are used for the shaft and hub support for quarter turn actuators. Both sleeves have an internal square drive (please observe stated measurement dimensions here). The sleeve material is sintered metal and they are chemically nickel plated with a surface of 25 µm.

## Certificates

Certificate	Standard	Item number
2.1 Certificate of compliance with the order	EN 10204	88039442
2.2 Functionality	EN 10204/EN 12266-2 F20	88439527
2.2 Pressure test	EN 10204, DIN EN 12266 P10, P11, P12	88039443
3.1 Body material	EN 10204	88314529
3.1 Disc material	EN 10204	88314530
3.1 Shaft material		88734227
3.1 Pressure test	EN 10204, DIN EN 12266 P10, P11, P12	88337125
3.1 Layer thickness measurement		88460229
3.1 Surface roughness measurement (only disc code B)		88094384



GEMÜ Gebr. Müller Apparatebau GmbH & Co. KG  
Gert-Müller-Platz 1, 74635 Kupferzell, Germany  
Phone +49 (0) 7940 1230 · info@gemue.de  
www.gemu-group.com