

## GEMÜ D40

Pneumatically operated diaphragm valve

EN

### Operating instructions



All rights including copyrights or industrial property rights are expressly reserved.

Keep the document for future reference.

© GEMÜ Gebr. Müller Apparatebau GmbH & Co. KG  
22.06.2026

## Contents

<b>1</b>	<b>General information</b>	<b>4</b>	<b>19</b>	<b>EU Declaration of Incorporation</b>	<b>25</b>
1.1	Information	4	<b>20</b>	<b>EU Declaration of Conformity</b>	<b>26</b>
1.2	Symbols used	4	<b>21</b>	<b>EU Declaration of Conformity</b>	<b>27</b>
1.3	Definition of terms	4			
1.4	Warning notes	4			
<b>2</b>	<b>Safety information</b>	<b>5</b>			
<b>3</b>	<b>Product description</b>	<b>5</b>			
3.1	Construction	5			
3.2	Description	6			
3.3	Function	6			
3.4	Product label	6			
<b>4</b>	<b>GEMÜ CONEXO</b>	<b>6</b>			
<b>5</b>	<b>Intended use</b>	<b>6</b>			
5.1	Product with special function X	6			
5.2	Product without special function X	7			
<b>6</b>	<b>Order data</b>	<b>8</b>			
6.1	Order codes	8			
6.2	Order example	9			
<b>7</b>	<b>Technical data</b>	<b>10</b>			
7.1	Medium	10			
7.2	Temperature	10			
7.3	Pressure	10			
7.4	Product conformities	12			
7.5	Mechanical data	12			
<b>8</b>	<b>Dimensions</b>	<b>14</b>			
8.1	Actuator dimensions	14			
8.2	Body dimensions	15			
<b>9</b>	<b>Manufacturer's information</b>	<b>18</b>			
9.1	Delivery	18			
9.2	Packaging	18			
9.3	Transport	18			
9.4	Storage	18			
<b>10</b>	<b>Installation in piping</b>	<b>18</b>			
10.1	Preparing for installation	18			
10.2	Installation with butt weld spigots	19			
10.3	Installation with clamp connections	19			
10.4	After the installation	19			
10.5	Operation	19			
<b>11</b>	<b>Pneumatic connections</b>	<b>20</b>			
11.1	Control function	20			
11.2	Connecting the control medium	20			
<b>12</b>	<b>Commissioning</b>	<b>20</b>			
<b>13</b>	<b>Operation</b>	<b>20</b>			
<b>14</b>	<b>Troubleshooting</b>	<b>21</b>			
<b>15</b>	<b>Inspection and maintenance</b>	<b>22</b>			
15.1	Spare parts	22			
15.2	Valve disassembly (removing the actuator from the body)	23			
15.3	Removing the diaphragm	23			
15.4	Mounting the diaphragm	23			
15.5	Mounting the actuator on the valve body	24			
<b>16</b>	<b>Removal from piping</b>	<b>24</b>			
<b>17</b>	<b>Disposal</b>	<b>24</b>			
<b>18</b>	<b>Returns</b>	<b>24</b>			

## 1 General information

### 1.1 Information

- The descriptions and instructions apply to the standard versions. For special versions not described in this document the basic information contained herein applies in combination with any additional special documentation.
- Correct installation, operation, maintenance and repair work ensure faultless operation of the product.
- Should there be any doubts or misunderstandings, the German version is the authoritative document.
- Contact us at the address on the last page for staff training information.

### 1.2 Symbols used

The following symbols are used in this document:

Symbol	Meaning
●	Tasks to be performed
▶	Response(s) to tasks
–	Lists

### 1.3 Definition of terms

#### Working medium

The medium that flows through the GEMÜ product.

#### Control function

The possible actuation functions of the GEMÜ product.

#### Control medium

The medium whose increasing or decreasing pressure causes the GEMÜ product to be actuated and operated.

### 1.4 Warning notes

Wherever possible, warning notes are organized according to the following scheme:

SIGNAL WORD	
Possible symbol for the specific danger	Type and source of the danger ▶Possible consequences in case of non-compliance ●Measures for avoiding danger

Warning notes are always labelled with a signal word and sometimes also with a symbol for the specific danger.

The following signal words and danger levels are used:

⚠ <b>DANGER</b>	
	<b>Imminent danger!</b> ▶ Non-observance can cause death or severe injury

⚠ <b>WARNING</b>	
	<b>Potentially dangerous situation!</b> ▶ Non-observance can cause death or severe injury

⚠ <b>CAUTION</b>	
	<b>Potentially dangerous situation!</b> ▶ Non-observance can cause moderate to light injury

<b>NOTICE</b>	
	<b>Potentially dangerous situation!</b> ▶ Non-observance can cause damage to property

The following symbols for the specific dangers can be used within a warning note:

Symbol	Meaning
	Danger of explosion!
	Risk of crushing due to moving parts when the valve is not installed!
	The equipment is subject to pressure!
	Hot plant components!
	Risk of injury due to moving parts when the valve is not installed!
	Danger of burning from hot surfaces!
	Risk of injury due to components being flung away!
	Hazardous media may escape if the diaphragm is faulty!
	Actuator under spring pressure!

## 2 Safety information

The safety information in this document refers only to an individual product. Potentially dangerous conditions can arise in combination with other plant components, which need to be considered on the basis of a risk analysis. The operator is responsible for the production of the risk analysis and for compliance with the resulting precautionary measures and regional safety regulations.

The document contains fundamental safety information that must be observed during commissioning, operation and maintenance. Non-compliance with these instructions may cause:

- Personal hazard due to electrical, mechanical and chemical effects
- Hazard to nearby equipment
- Failure of important functions
- Hazard to the environment due to the leakage of dangerous materials

The safety information does not take into account:

- Unexpected incidents and events, which may occur during installation, operation and maintenance
- Local safety regulations which must be adhered to by the operator and by any additional installation personnel

### Prior to commissioning:

1. Transport and store the product correctly.
2. Do not paint the bolts and plastic parts of the product.
3. Carry out installation and commissioning using trained personnel.
4. Provide adequate training for installation and operating personnel.
5. Ensure that the contents of the document have been fully understood by the responsible personnel.
6. Define the areas of responsibility.
7. Observe the safety data sheets.
8. Observe the safety regulations for the media used.

### During operation:

9. Keep this document available at the place of use.
10. Observe the safety information.
11. Operate the product in accordance with this document.
12. Operate the product in accordance with the specifications.
13. Maintain the product correctly.
14. Do not carry out any maintenance work and repairs not described in this document without consulting the manufacturer first.

### In cases of uncertainty:

15. Consult the nearest GEMÜ sales office.

## 3 Product description

### 3.1 Construction

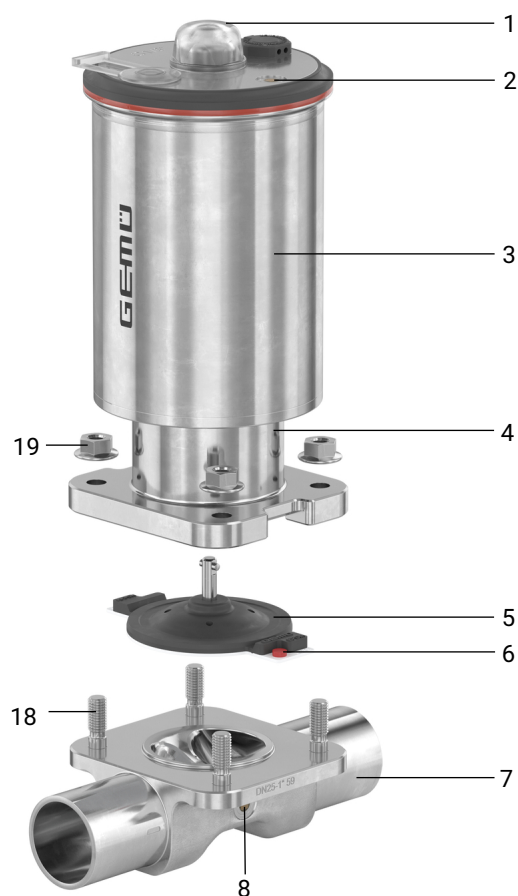

Position	Name	Materials
1	Transparent cap	PC
2	CONEXO actuator RFID chip (see Conexo information)	
3	Actuator	1.4301 / 1.4308
4	Distance piece with leak detection hole	1.4308 / 1.4408
5	Diaphragm	PTFE/EPDM two-piece
6	CONEXO diaphragm RFID chip (see Conexo information)	
7	Valve body	1.4435 (F316L), forged body 1.4435 (316L), block material 1.4435 (BN2), forged body, $\Delta Fe < 0.5\%$ 1.4435 (BN2), block material, $\Delta Fe < 0.5\%$
8	CONEXO body RFID chip (see Conexo information)	
18, 19	Screw connection kit (stud bolts, flange nuts)	

### 3.2 Description

The pneumatically operated diaphragm valve GEMÜ D40 is designed for use in sterile applications. The diaphragm hermetically separates the actuator from the working medium. All actuator parts (except the seals and design elements) are made from stainless steel. The “Normally closed”, “Normally open” and “Double acting” control functions are available.

### 3.3 Function

The GEMÜ D40 stainless steel diaphragm valve with 2/2-way body features a piston actuator and is equipped with an optical position indicator as standard. The media-wetted area of the valve is CIP/SIP capable.

### 3.4 Product label

The product label is located on the actuator. Product label data (example):

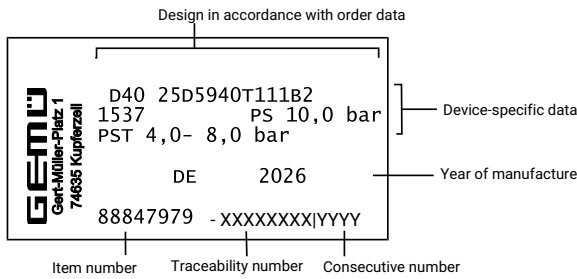

The month of manufacture is encoded in the traceability number and can be obtained from GEMÜ. The product was manufactured in Germany.

### 4 GEMÜ CONEXO

The interaction of valve components that are equipped with RFID chips and an associated IT infrastructure actively increase process reliability.



The diaphragm is read out using an RFID reader, the CONEXO pen. The CONEXO app, which can be installed on mobile devices, not only facilitates and improves the “installation qualification” process, but also makes the maintenance process much more transparent and easier to document. The app actively guides the maintenance technician through the maintenance schedule and directly provides them with all the information assigned to the valve, such as test reports, testing documentation and maintenance histories. The CONEXO portal acts as a central element, helping to collect, manage and process all data.

You can find further information on GEMÜ CONEXO at: [www.gemu-group.com/conexo](http://www.gemu-group.com/conexo)

### 5 Intended use

<b>⚠ DANGER</b>	
	<p><b>Danger of explosion!</b></p> <ul style="list-style-type: none"> <li>▶ Risk of severe injury or death</li> <li>● If there is no corresponding declaration of conformity, the product must not be used in potentially explosive atmospheres!</li> <li>● Only use the product in potentially explosive zones confirmed in the declaration of conformity.</li> </ul>
<b>⚠ WARNING</b>	
<p><b>Improper use of the product!</b></p> <ul style="list-style-type: none"> <li>▶ Risk of severe injury or death</li> <li>▶ Manufacturer liability and guarantee will be void.</li> <li>● Only use the product in accordance with the operating conditions specified in the contract documentation and in this document.</li> </ul>	

The product is designed for installation in piping systems and for controlling a working medium.

1. Use the product in accordance with the technical data.
2. Note the supplement acc. to ATEX.
3. Please note the flow direction on the valve body.

#### 5.1 Product with special function X

With the special version X order option, the product is intended for use in potentially explosive areas in zone 1 with gases, mists or vapours and zone 21 with combustible dusts in accordance with EU Directive 2014/34/EU (ATEX).

The product has the following explosion protection marking:

Gas:  II 2 G Ex h IIC T6 ... T3 Gb X

Dust:  II -/2 D Ex h -/IIIC T150 °C -/Db X

The product has been developed in compliance with the following harmonized standards:

- EN 1127-1:2019
- EN IEC 80079-36 authorization 1:2024
- EN IEC 80079-36:2016
- EN IEC 80079-37:2016

**For use in potentially explosive areas, the following special conditions or operation limits must be observed:**

- Temperature class depending on the temperature of the conveyed medium and the clock frequency (for T6, do not clock faster than once per second).
- For liquids and gases or gas compounds (free of aerosols and particulates). If gases or gas compounds are not free of aerosols and particulates (hybrid mixtures), the operator must take special measures for compliance with explosion protection.
- For the ambient temperature range, see technical data.
- For products with a Conexo RFID chip, see the supplement "Special conditions for products with a RFID chip".
- In the EX area, only remove the valve manually (remove the actuator from the body).
- Must be integrated into the equipotential bonding of the entire system.

## **5.2 Product without special function X**

The product is not intended for use in potentially explosive areas.

## 6 Order data

The order data provide an overview of standard configurations.

Please check the availability before ordering. Other configurations available on request.

### Order codes

1 Type	Code
Diaphragm valve, pneumatically operated, stainless steel piston actuator	D40

2 DN, connection 1	Code
DN 10	10
DN 15	15
DN 20	20
DN 25	25
DN 32	32
DN 40	40

3 Body configuration	Code
2/2-way body	D

4 Valve body connection type, connection 1	Code
Spigot EN 10357 series A/DIN 11866 series A	17
Spigot ASME BPE/DIN EN 10357 series C (from 2022 edition)/DIN 11866 series C	59
Spigot ISO 1127/DIN EN 10357 series C (2014 edition)/DIN 11866 series B	60
Clamp ASME BPE, for pipe ASME BPE, face-to-face dimension FTF ASME BPE, length only for body configuration D	80
Clamp DIN 32676, for pipe DIN 11866 series B, face-to-face dimension FTF EN 558 series 7, length only for body configuration D	82
Clamp ASME BPE, for pipe ASME BPE, face-to-face dimension FTF EN 558 series 7, length only for body configuration D	88
Clamp DIN 32676, for pipe DIN 11866 series A, face-to-face dimension FTF acc. to EN 558 series 7, length only for body configuration D	8A
Clamp DIN 32676, for pipe DIN 11866 series C, face-to-face dimension FTF ASME BPE, length only for body configuration D	8P
Clamp DIN 32676, for pipe DIN 11866 series C, face-to-face dimension FTF EN 558 series 7, length only for body configuration D	8T

5 Valve body material	Code
1.4435 (F316L), forged body	40
1.4435 (316L), block material	41
1.4435 (BN2), forged body, $\Delta Fe < 0.5\%$	42
1.4435 (BN2), block material, $\Delta Fe < 0.5\%$	43
Material code 41 and code 43 on request	

6 Diaphragm material	Code
PTFE/EPDM, two-piece	T1

7 Control function	Code
Normally closed (NC)	1
Normally open (NO)	2
Double acting (DA)	3

8 Actuator spring set	Code
Standard spring set	1

9 Diaphragm size	Code
Diaphragm size B	B
Diaphragm size C	C

10 Actuator size	Code
Actuator size 2	2
Actuator size 3	3
Actuator size 4	4

11 Valve body surface	Code
Ra $\leq 0.4 \mu\text{m}$ for media wetted surfaces, in accordance with DIN 11866 H4, mechanically polished internal mechanically machined internal	1536
Ra $\leq 0.4 \mu\text{m}$ for media wetted surfaces, in accordance with DIN 11866 HE4, electropolished internal/external	1537
Ra max. $0.51 \mu\text{m}$ (20 $\mu\text{in.}$ ) for media wetted surfaces, in accordance with ASME BPE SF1, mechanically machined internal	SF1
Ra max. $0.38 \mu\text{m}$ (15 $\mu\text{in.}$ ) for media wetted surfaces, in accordance with ASME BPE SF4, electropolished internal/external	SF4

12 CONEXO	Code
Integrated RFID chip for electronic identification and traceability	C
Without	

13 Special function	Code
ATEX marking	X

**Order example**

Ordering option	Code	Description
1 Type	D40	Diaphragm valve, pneumatically operated, stainless steel piston actuator
2 DN, connection 1	15	DN 15
3 Body configuration	D	2/2-way body
4 Valve body connection type, connection 1	17	Spigot EN 10357 series A/DIN 11866 series A
5 Valve body material	40	1.4435 (F316L), forged body
6 Diaphragm material	T1	PTFE/EPDM, two-piece
7 Control function	1	Normally closed (NC)
8 Actuator spring set	1	Standard spring set
9 Diaphragm size	B	Diaphragm size B
10 Actuator size	2	Actuator size 2
11 Valve body surface	1537	Ra ≤ 0.4 µm for media wetted surfaces, in accordance with DIN 11866 HE4, electropolished internal/external
12 CONEXO		Without
13 Special function	X	ATEX marking

**7 Technical data**

**7.1 Medium**

**Working medium:** Corrosive, inert, gaseous and liquid media which have no negative impact on the physical and chemical properties of the body and diaphragm material.

**Control medium:** Inert gases

**7.2 Temperature**

<b>Media temperature:</b>	Diaphragm material	Standard
	PTFE/EPDM (code T1)	-10 to 100 °C

**Ambient temperature:** -10 – 80 °C

**Control medium temperature:** 0 – 60 °C

**Sterilization temperature:** PTFE/EPDM (code T1): Max. 150 °C, maximum 180 min per cycle  
 The sterilization temperature is valid for steam (saturated steam) or superheated water (max. 6 bar). PTFE diaphragms can also be used as moisture barriers; however, this will reduce their service life. It is not possible to retighten the connecting screws between the actuator and the valve body. This also applies to PTFE diaphragms exposed to high temperature fluctuations. The maintenance cycles must be adapted accordingly. The following valve arrangement has proven itself for interfaces between steam and process pipes: A globe valve for shutting off steam pipes and a diaphragm valve as an interface to the process pipes.

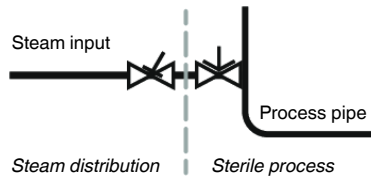

**Storage temperature:** -10 – 40 °C

**7.3 Pressure**

**Operating pressure:** 0 – 16 bar  
 Information on operating pressures applied on both sides and for high purity media on request. Diaphragms with code T1 in valves in the 0–16 bar design have a reduced service life compared to the 0–10 bar design.

MG	DN	Actuator size	Diaphragm material	
			PTFE	
			Control function 1	Control function 2+3
<b>B</b>	<b>10 - 25</b>	<b>2</b>	0–10.0	0–10.0*
		<b>3</b>	0–16.0	-
<b>C</b>	<b>20 - 40</b>	<b>3</b>	0–5.0	0–5.0
		<b>4</b>	0–10.0	-

MG = diaphragm size

All pressures are gauge pressures. Operating pressure values were determined with static operating pressure applied on one side of a closed valve. Sealing at the valve seat and atmospheric sealing is ensured for the given values.

\* As a guide for operating the system with low wear on the diaphragm, refer to the control pressure – operating pressure diagrams below.

**Vacuum:** Can be used up to a vacuum of 70 mbar (absolute)

**Pressure rating:** PN 16

**Leakage rate:** Leakage rate A to P11/P12 EN 12266-1

**Filling volume:**

Actuator size	Diaphragm size	Control function		Valve stroke
		NC	NO	
2	B	0.06 dm <sup>3</sup>	0.05 dm <sup>3</sup>	7.5 mm
3	C	0.09 dm <sup>3</sup>	0.08 dm <sup>3</sup>	11.8 mm
4	C	0.181 dm <sup>3</sup>	0.193 dm <sup>3</sup>	11.8 mm

NC = filling volume when open, NO = filling volume when closed

**Control pressure:**

**Control function 1**

4.0 Up to 8.0 bar

**Control function 2 and 3: Control pressure/operating pressure diagram**

GEMÜ D40 design, diaphragm size B, actuator size 2

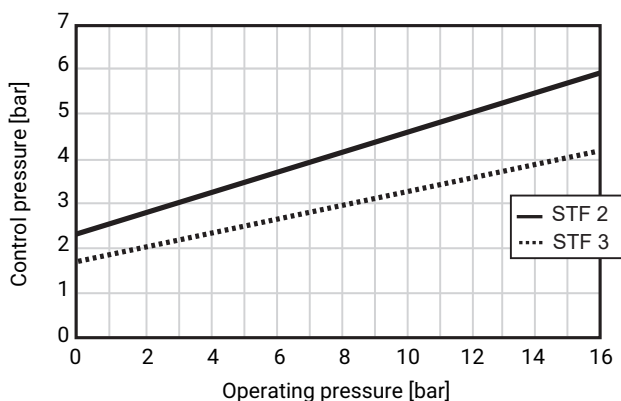

Stf. = control function

**Control function 2 and 3: Control pressure/operating pressure diagram**

GEMÜ D40 design, diaphragm size C, actuator size 4

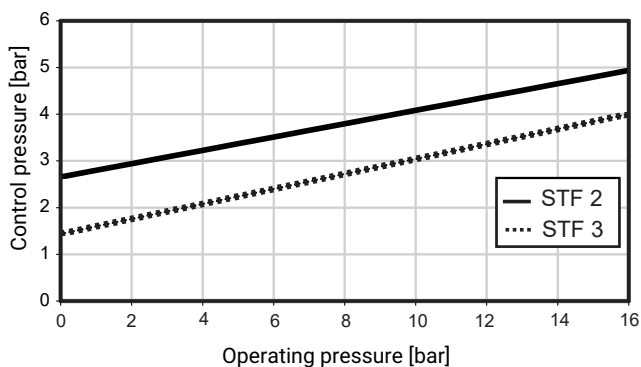

Stf. = control function

The control pressure depending on the prevailing operating pressure, as shown in the diagram, is intended as a guide for operating the system with low wear on the diaphragm.

**Kv values:**

Diaphragm size	DN	Connection type (code)		
		17	59	60
<b>B</b>	<b>10</b>	4.4	-	8.0
	<b>15</b>	9.5	3.9	9.5
	<b>20</b>	9.5	9.5	-
	<b>25</b>	-	9.5	-
<b>C</b>	<b>20</b>	16.5	-	23.2
	<b>25</b>	25.3	22.0	26.4
	<b>32</b>	26.4	-	24.3
	<b>40</b>	24.6	25.2	-

MG = diaphragm size, Kv values in m<sup>3</sup>/h



Kv values determined in accordance with EN 60534, inlet pressure 5 bar, Δp 1 bar, stainless steel valve body and two-piece PTFE/EPDM diaphragm. The Kv values for other product configurations (e.g. other diaphragm or body materials) may differ. In general, all diaphragms are subject to the influences of pressure, temperature and process parameters, as a result of which the Kv values deviate beyond the tolerance limit of the standard. The Kv value curve (Kv value dependent on valve stroke) can vary depending on the diaphragm material and term of use.

**7.4 Product conformities**

**Machinery Directive:** 2006/42/EC

**Pressure Equipment Directive:** 2014/68/EU

**Explosion protection:** ATEX (2014/34/EU), order code Special version X

**ATEX marking:** Gas:  II 2 G Ex h IIC T6 ... T3 Gb X  
Dust :  II -/2 D Ex h -/IIIC T150 °C -/Db X

**Food:** FDA  
USP Class VI  
Regulation (EC) No. 1935/2004 (for material code 40 only)  
Regulation (EC) No. 10/2011

**7.5 Mechanical data****Weight:****Body**

MG	DN	Spigot		
		Connection type code		
		17	59	60
<b>B</b>	<b>10</b>	0.33	-	0.32
	<b>15</b>	0.31	0.34	0.3
	<b>20</b>	0.28	0.31	-
	<b>25</b>	-	0.27	-
<b>C</b>	<b>20</b>	1.00	-	0.97
	<b>25</b>	0.94	0.98	0.89
	<b>32</b>	0.86	-	0.80
	<b>40</b>	0.78	0.81	-

Weights in kg  
MG = diaphragm size

**Weight:****Actuator (control function 1, NC)**

MG	Actuator size	Weight
<b>B</b>	2	1.7
<b>B</b>	3	1.2
<b>C</b>	3	1.4
<b>C</b>	4	3.8

Weights in kg  
MG = diaphragm size

**Angle of rotation:**

MG	DN	Connection type (code)		
		17	59	60
$\alpha$				
<b>B</b>	<b>10</b>	36.3°	-	23.4°
	<b>15</b>	18.0°	38.1°	12.3°
	<b>20</b>	7.9°	18.3°	-
	<b>25</b>	-	3.0°	-
<b>C</b>	<b>20</b>	35.4°	-	28.4°
	<b>25</b>	24.5°	31.2°	18.1°
	<b>32</b>	14.9°	-	5.9°
	<b>40</b>	7.9°	10.8°	-

MG = diaphragm size

Vertical line:  
Reference line for hash mark

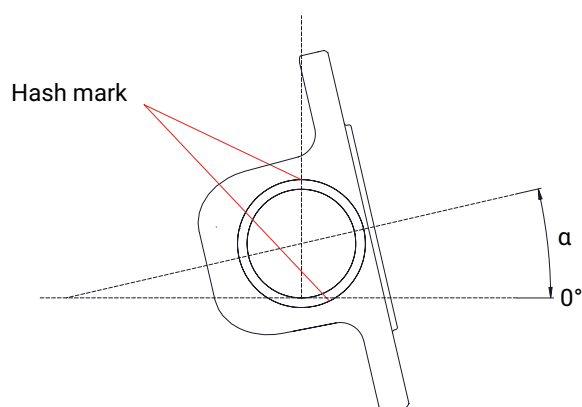

Horizontal line:  
Reference line for the angle of rotation

## 8 Dimensions

### 8.1 Actuator dimensions

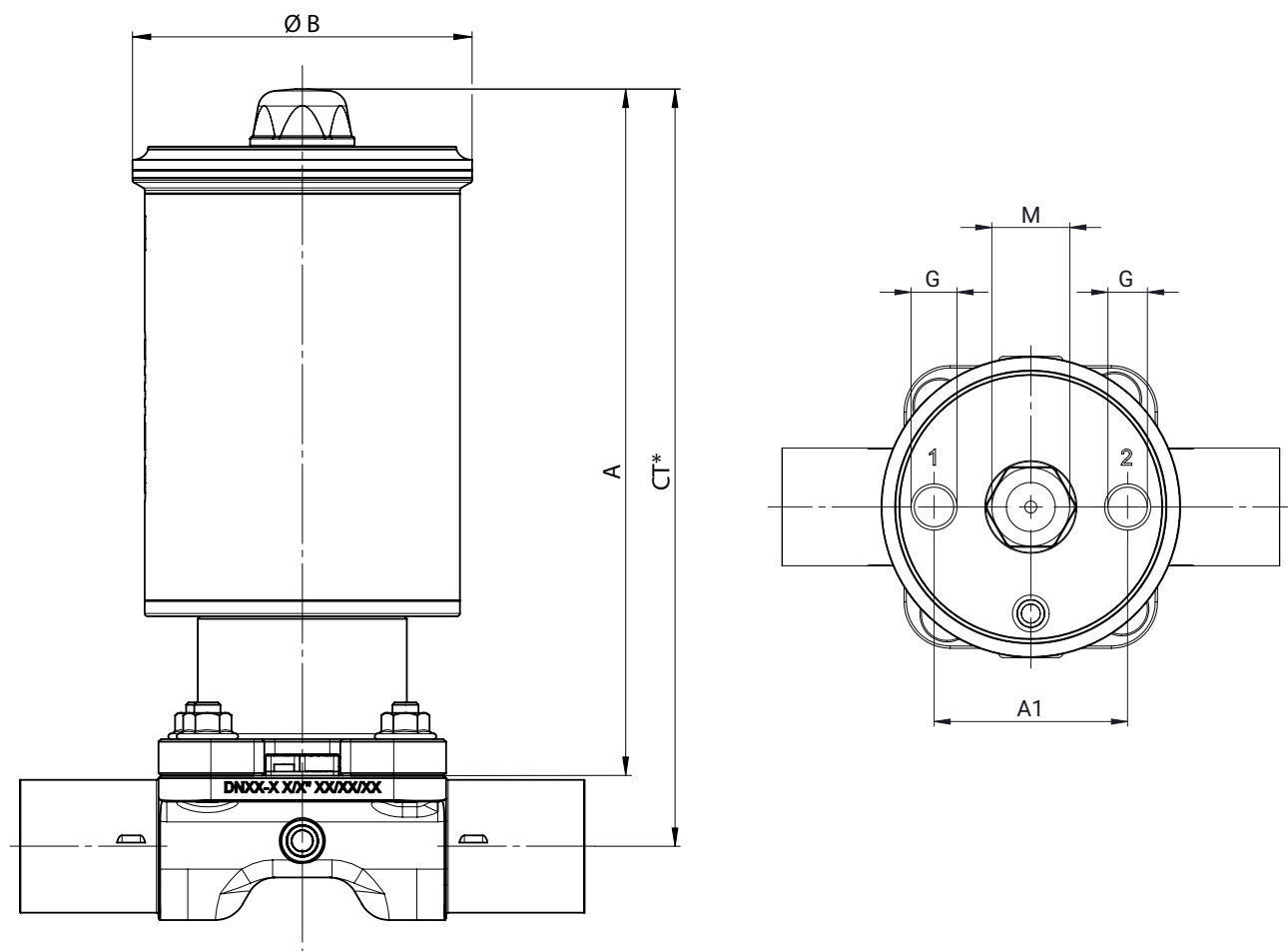

Actuator size	MG	A	$\varnothing B$	A1	G	M
2	B	131.3	65.0	42.0	G 1/8	M16x1
3	B	136.8	70.0	42.0	G 1/8	M16x1
3	C	154.1	70.0	42.0	G 1/8	M16x1
4	C	186.5	88.9	61.0	G 1/4	M26x1.5

Dimensions in mm

MG = diaphragm size

\* CT = A + H1 (see body dimensions)

## 8.2 Body dimensions

### 8.2.1 Spigot DIN/EN/ISO/ASME (code 17, 59, 60), forged material (code 40, 42)

Connection type spigot DIN/EN/ISO/ASME (codes 17, 59, 60)<sup>1)</sup>, forged material (code 40)<sup>2)</sup>

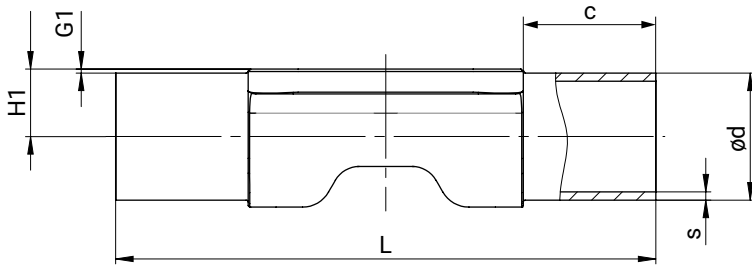

MG	DN	Pipe standard			EN 10357 series A/DIN 11866 series A	ASME BPE/DIN 11866 series C	ISO 1127/EN 10357 series C/DIN 11866 series B						
					Connection code								
					17	59	60						
		L	c (min)	G1	H1	Ød	s	H1	Ød	s	H1	Ød	s
<b>B</b>	<b>10</b>	108.0	25.0	0.8	7.3	13.0	1.5	5.57	9.53	0.89	9.4	17.2	1.6
	<b>15</b>	108.0	25.0	0.8	10.3	19.0	1.5	7.15	12.70	1.65	11.45	21.3	1.6
	<b>20</b>	108.0	25.0	0.8	12.3	23.0	1.5	10.33	19.05	1.65	-	-	-
	<b>25</b>	108.0	25.0	0.8	-	-	-	13.50	25.40	1.65	-	-	-
<b>C</b>	<b>20</b>	127.0	25.0	0.8	12.3	23.0	1.5	-	-	-	14.25	26.9	1.6
	<b>25</b>	127.0	25.0	0.8	15.3	29.0	1.5	13.5	25.4	1.65	17.65	33.7	2.0
	<b>32</b>	127.0	25.0	0.8	18.3	35.0	1.5	-	-	-	22.0	42.4	2.0
	<b>40</b>	127.0	25.0	0.8	21.3	41.0	1.5	19.85	38.1	1.65	-	-	-

Dimensions in mm

MG = diaphragm size

#### 1) Connection type

Code 17: Spigot EN 10357 series A/DIN 11866 series A, formerly DIN 11850 series 2

Code 59: Spigot ASME BPE/DIN EN 10357 series C (from 2022 edition)/DIN 11866 series C

Code 60: Spigot ISO 1127/DIN EN 10357 series C (2014 edition)/DIN 11866 series B

#### 2) Valve body material

Code 40: 1.4435 (F316L), forged body

Code 42: 1.4435 (BN2), forged body,  $\Delta Fe < 0.5\%$

**8.2.2 Clamp DIN/EN/ISO/ASME (codes 80, 82, 88, 8A, 8P, 8T), forged material (code 40, 42)**

Connection type clamp DIN/ASME (codes 80, 88, 8P, 8T)<sup>1)</sup>, forged material (code 40, 42)<sup>2)</sup>

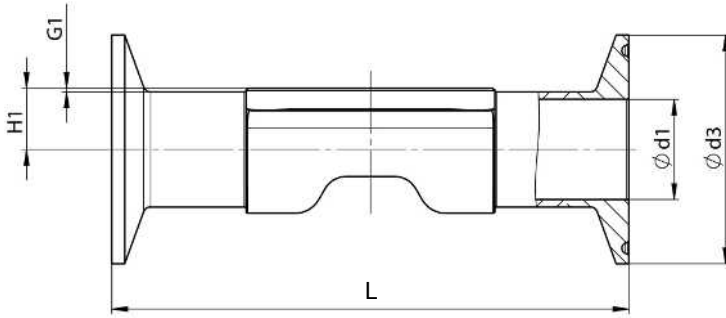

MG	DN	NPS	ød1		ød3		H1	G1	L	
			Connection type		Connection type				Connection type	
			80, 8P	88, 8T	80, 8P	88, 8T			80, 8P	88, 8T
<b>B</b>	<b>10</b>	3/8"	-	-	-	-	-	0.8	-	-
	<b>15</b>	1/2"	9.40	9.40	25.00	25.00	7.15	0.8	88.90	108.00
	<b>20</b>	3/4"	15.75	15.75	25.00	25.00	10.33	0.8	101.60	117.00
	<b>25</b>	1"	22.10	22.10	50.50	50.50	13.50	0.8	114.30	127.00
<b>C</b>	<b>20</b>	3/4"	-	-	-	-	-	0.8	-	-
	<b>25</b>	1"	22.10	22.10	50.50	50.50	13.50	0.8	114.30	127.00
	<b>32</b>	1 1/4"	-	-	-	-	-	0.8	-	-
	<b>40</b>	1 1/2"	34.80	34.80	50.50	50.50	19.85	0.8	139.70	159.00

Dimensions in mm

MG = diaphragm size

**1) Connection type**

Code 80: Clamp ASME BPE, face-to-face dimension FTF ASME BPE, length only for body configuration D

Code 88: Clamp ASME BPE, for pipe ASME BPE, face-to-face dimension FTF EN 558 series 7, length only for body configuration D

Code 8P: Clamp DIN 32676 series C, face-to-face dimension FTF ASME BPE, length only for body configuration D

Code 8T: Clamp DIN 32676 series C, face-to-face dimension FTF EN 558 series 7, length only for body configuration D

**2) Valve body material**

Code 40: 1.4435 (F316L), forged body

Code 42: 1.4435 (BN2), forged body, Δ Fe < 0.5%

**Connection type clamp DIN/ISO (code 82)<sup>1)</sup>, forged material (code 40, 42)<sup>2)</sup>**

MG	DN	NPS	ød1	ød3	H1	G1	L
			Connection type	Connection type			Connection type
			82	82			82
<b>B</b>	<b>10</b>	3/8"	14.00	25.00	9.4	0.8	108.00
	<b>15</b>	1/2"	18.10	50.50	11.45	0.8	108.00
	<b>20</b>	3/4"	-	-	-	0.8	-
	<b>25</b>	1"	-	-	-	0.8	-
<b>C</b>	<b>20</b>	3/4"	23.00	50.50	14.25	0.8	117.00
	<b>25</b>	1"	29.70	50.50	17.65	0.8	127.00
	<b>32</b>	1¼"	38.40	64.00	22	0.8	146.00
	<b>40</b>	1½"	-	-	-	0.8	-

Dimensions in mm

MG = diaphragm size

**1) Connection type**

Code 82: Clamp DIN 32676 Series B, Overall length FTF EN 558 Series 7, Overall length only for housing type D

**2) Valve body material**

Code 40: 1.4435 (F316L), forged body

Code 42: 1.4435 (BN2), forged body, Δ Fe &lt; 0.5%

**Connection type clamp DIN/EN (code 8A)<sup>1)</sup>, forged material (code 40, 42)<sup>2)</sup>**

MG	DN	NPS	ød1	ød3	H1	G1	L
			Connection type	Connection type			Connection type
			8A	8A			8A
<b>B</b>	<b>10</b>	3/8"	10.00	34.00	7.30	0.8	108.00
	<b>15</b>	1/2"	16.00	34.00	10.30	0.8	108.00
	<b>20</b>	3/4"	20.00	34.00	12.30	0.8	117.00
	<b>25</b>	1"	-	-	-	0.8	-
<b>C</b>	<b>20</b>	3/4"	20.00	34.00	12.30	0.8	117.00
	<b>25</b>	1"	26.00	50.50	15.30	0.8	127.00
	<b>32</b>	1¼"	32.00	50.50	18.30	0.8	146.00
	<b>40</b>	1½"	38.00	50.50	21.30	0.8	159.00

Dimensions in mm

MG = diaphragm size

**1) Connection type**

Code 8A: Clamp DIN 32676 Series A, Overall length FTF according to EN 558 Series 7, Overall length only for housing type D

**2) Valve body material**

Code 40: 1.4435 (F316L), forged body

Code 42: 1.4435 (BN2), forged body, Δ Fe &lt; 0.5%

## 9 Manufacturer's information

### 9.1 Delivery

- Check that all parts are present and check for any damage immediately upon receipt.

The product's performance is tested at the factory. The scope of delivery is apparent from the dispatch documents and the design from the order number.

### 9.2 Packaging

The product is packaged in a cardboard box which can be recycled as paper.

### 9.3 Transport



1. Only transport the product by suitable means. Do not drop. Handle carefully.
2. After the installation dispose of transport packaging material according to relevant local or national disposal regulations / environmental protection laws.

### 9.4 Storage

1. Store the product free from dust and moisture in its original packaging.
2. Avoid UV rays and direct sunlight.
3. Do not exceed the maximum storage temperature (see chapter "Technical data").
4. Do not store solvents, chemicals, acids, fuels or similar fluids in the same room as GEMÜ products and their spare parts.
5. Close the compressed air connections with protection caps or sealing plugs.

## 10 Installation in piping

### 10.1 Preparing for installation

<b>⚠ WARNING</b>	
	<p><b>Risk of crushing due to moving parts when the valve is not installed!</b></p> <ul style="list-style-type: none"> <li>▶ Upper limbs may get into the valve body openings while working on the valve.</li> <li>● Ensure that the valve is in the respective end position (closed for NC or open for NO).</li> <li>● Do not reach into the crushing area through the valve body openings.</li> </ul>
<b>⚠ WARNING</b>	
	<p><b>The equipment is subject to pressure!</b></p> <ul style="list-style-type: none"> <li>▶ Risk of severe injury or death</li> <li>● Depressurize the plant or plant component.</li> <li>● Completely drain the plant or plant component.</li> </ul>

<b>⚠ CAUTION</b>	
	<p><b>Hot plant components!</b></p> <ul style="list-style-type: none"> <li>▶ Risk of burns</li> <li>● Only work on plant that has cooled down.</li> </ul>

<b>⚠ CAUTION</b>	
	<p><b>Risk of injury due to moving parts when the valve is not installed!</b></p> <ul style="list-style-type: none"> <li>▶ The valve spindle and diaphragm are moving parts that are moved with high force. This may lead to injuries when working on the valve.</li> <li>● Watch out for moving parts when operating the actuator.</li> <li>● Do not reach between the diaphragm, valve spindle and modified plant components.</li> <li>● Have servicing and maintenance work carried out by trained personnel only.</li> </ul>

<b>NOTICE</b>	
<b>Maximum permissible pressure exceeded.</b>	
<ul style="list-style-type: none"> <li>▶ Damage to the product</li> <li>● Provide for precautionary measures against exceeding the maximum permissible pressure that may be caused by pressure surges (water hammer).</li> </ul>	

<b>NOTICE</b>	
<b>Suitability of the product!</b>	
<ul style="list-style-type: none"> <li>▶ The product must be appropriate for the piping system operating conditions (medium, medium concentration, temperature and pressure) and the prevailing ambient conditions.</li> </ul>	

**NOTICE****Tools!**

- ▶ The tools required for installation and assembly are not included in the scope of delivery.
- Use appropriate, functional and safe tools.

1. Ensure the product is suitable for the relevant application.
2. Check the technical data of the product and the materials.
3. Keep appropriate tools ready.
4. Wear appropriate protective gear, as specified in the plant operator's guidelines.
5. Observe appropriate regulations for connections.
6. Have installation work carried out by trained personnel.
7. Shut off plant or plant component.
8. Secure plant or plant component against recommissioning.
9. Depressurize the plant or plant component.
10. Completely drain the plant (or plant component) and let it cool down until the temperature is below the media vaporization temperature and cannot cause scalding.
11. Correctly decontaminate, rinse and ventilate the plant or plant component.
12. Lay piping so that the product is protected against transverse and bending forces, and also from vibrations and tension.
13. Only install the product between matching aligned pipes (see chapters below).

**10.2 Installation with butt weld spigots**

Fig. 1: Butt weld spigots

1. Carry out preparations for installation (see chapter "Preparing for installation").
2. Adhere to good welding practices!
3. Disassemble the actuator with the diaphragm before welding the valve body into the pipeline, see Valve disassembly (removing actuator from body).
4. Weld the body of the product in the piping.
5. Allow butt weld spigots to cool down.
6. Reassemble the valve body and the actuator with diaphragm, see Actuator mounting on the valve body.
7. Re-attach or reactivate all safety and protective devices.
8. Flush the system.

**10.3 Installation with clamp connections**

Fig. 2: Clamp connection

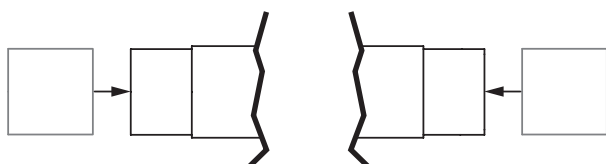
**NOTICE****Gasket and clamp!**

- ▶ The gasket and clamps for clamp connections are not included in the scope of delivery.

1. Keep ready gasket and clamp.
2. Carry out preparation for installation (see chapter "Preparing for installation").
3. Insert the corresponding gasket between the body of the product and the pipe connection.
4. Connect the gasket between the body of the product and the pipe connection using clamps.
5. Re-attach or reactivate all safety and protective devices.

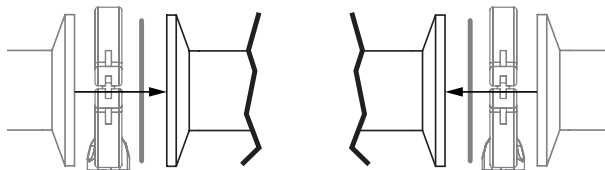
**10.4 After the installation**

- Re-attach or reactivate all safety and protective devices.

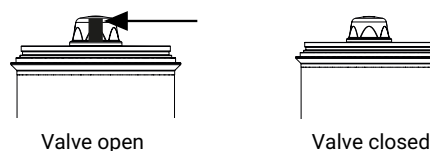
**10.5 Operation****Optical position indicator**

## 11 Pneumatic connections

### 11.1 Control function

The following control functions are available:

#### Control function 1

##### Normally closed (NC):

Valve resting position: Closed by spring force. Activation of the actuator (connector 1) opens the valve. When the actuator is vented, the valve is closed by spring force.

#### Control function 2

##### Normally open (NO):

Valve resting position: Opened by spring force. Activation of the actuator (connector 2) closes the valve. When the actuator is vented, the valve is opened by spring force.

#### Control function 3

##### Double acting (DA):

Valve resting position: No defined normal position. The valve is opened and closed by activating the respective control medium connectors (connector 1: Open/connector 2: Close).

Control function	Connectors	
	1	2
1 (NC)	+	-
2 (NO)	-	+
3 (DA)	+	+

+ = available/- = not available  
(see figure for connectors 1/2)

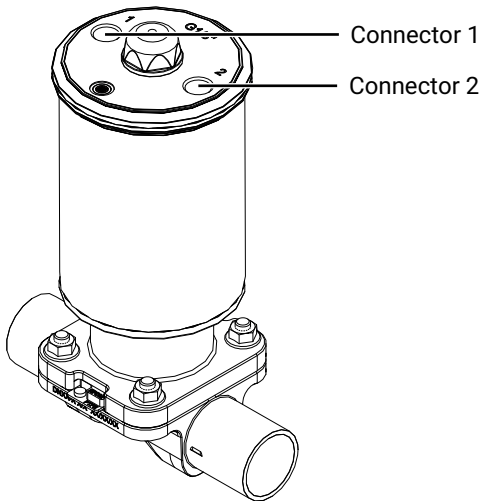

### 11.2 Connecting the control medium

Thread size of the control medium connectors:

G1/8" for AG2

1. Use suitable connectors.
2. Connect the control medium lines tension-free and without any bends or knots in connector 1.

## 12 Commissioning

1. Check the tightness and the function of the product (close and reopen the product).
2. Flush the piping system for new plants and after repair work (the product must be fully open).
  - ⇒ Harmful foreign matter has been removed.
  - ⇒ The product is ready for use.
3. Commission the product.

## 13 Operation

**⚠ WARNING**

**Danger of burning from hot surfaces!**

- ▶ The valve housing and valve body can become hot during operation and cause burns.
- Allow the valve housing and valve body to cool down before working on the valve.
- Wear appropriate protective gloves.

**⚠ CAUTION**

**Risk of injury due to components being flung away!**

- ▶ In the event of excessive control pressure, components of the actuator may be flung away and cause injuries.
- Only actuate the valve with the maximum control pressures stated in the operating instructions.

**NOTICE**

**Maximum permissible pressure exceeded.**

- ▶ Damage to the product
- Provide for precautionary measures against exceeding the maximum permissible pressure that may be caused by pressure surges (water hammer).

Operate the product according to the control function (see also chapter "Pneumatic connections").

## 14 Troubleshooting

### WARNING



#### Hazardous media may escape if the diaphragm is faulty!

- ▶ Risk of injury due to contact with media that is harmful to health!
- Replace the diaphragms once they have reached their service life limits.
- Wear suitable protective gear while working on the product, depending on the working medium used.

Error	Error cause	Troubleshooting
Control medium escaping from connector 2* for control function NC (see chapter "Control functions")	Piston seal leaking	Replace product
Control medium escaping from leak detection hole* (only with NC control function)	Spindle seal leaking	Replace product and check control medium for impurities
Working medium escaping from leak detection hole*	Shut off diaphragm is defective	Replace product
The product does not open or does not open fully	Control pressure too low (for control function NC)	Operate the product with the control pressure specified in the datasheet
	Pilot valve faulty	Check and replace pilot valve
	Control medium not connected	Connect control medium
	Bottom spindle seal or piston seal leaking	Replace the product
	Actuator defective	Replace the actuator
The product is leaking downstream (does not close or does not close fully)	Operating pressure too high	Operate the product with operating pressure specified in datasheet
	Foreign matter between shut-off diaphragm and valve body	Remove the actuator, remove foreign matter, check diaphragm and valve body for potential damage, replace damaged parts if necessary
	Valve body leaking or damaged	Carry out initialisation, check valve body for damage, replace valve body if necessary.
	Shut-off diaphragm is defective	Check shut-off diaphragm for potential damage, replace diaphragm if necessary
	Actuator spring faulty (for control function NC)	Replace actuator
Connection between valve body and piping leaking	Incorrect installation	Check installation of valve body in piping

\* see the "Construction" chapter

## 15 Inspection and maintenance

**⚠ WARNING**



**Risk of crushing due to moving parts when the valve is not installed!**

- ▶ Upper limbs may get into the valve body openings while working on the valve.
- Ensure that the valve is in the respective end position (closed for NC or open for NO).
- Do not reach into the crushing area through the valve body openings.

**⚠ WARNING**



**The equipment is subject to pressure!**

- ▶ Risk of severe injury or death
- Depressurize the plant or plant component.
- Completely drain the plant or plant component.

**⚠ CAUTION**



**Hot plant components!**

- ▶ Burns
- Only work on plant that has cooled down.
- Wear protective gear.

**⚠ CAUTION**



**Risk of injury due to moving parts when the valve is not installed!**

- ▶ The valve spindle and diaphragm are moving parts that are moved with high force. This may lead to injuries when working on the valve.
- Watch out for moving parts when operating the actuator.
- Do not reach between the diaphragm, valve spindle and modified plant components.
- Have servicing and maintenance work carried out by trained personnel only.

**NOTICE**

**Use of incorrect spare parts!**

- ▶ Damage to the GEMÜ product
- ▶ The manufacturer liability and guarantee will be void.
- Use only genuine parts from GEMÜ.

1. Wear appropriate protective gear in accordance with the plant operator's guidelines.
2. Shut off the plant or plant component.
3. Secure against recommissioning.
4. Depressurize the plant or plant component.

The operator must carry out regular visual examinations of the valves, depending on the operating conditions and the potentially hazardous situations, in order to prevent leakage and damage. The valve also has to be disassembled and checked for wear in corresponding intervals.

### 15.1 Spare parts

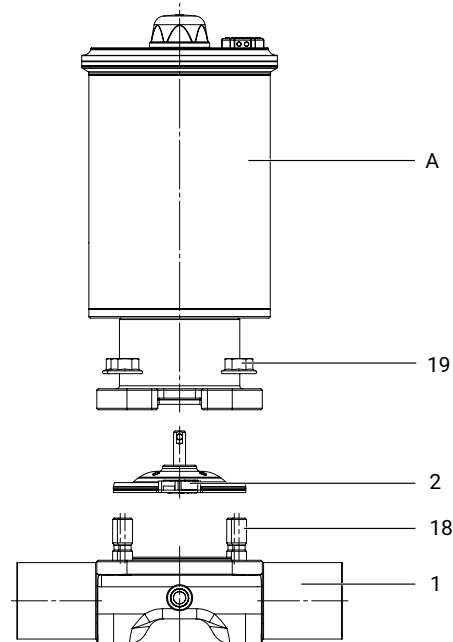

Item	Name	Order designation
A	Actuator	AD40...
1	Valve body	BD00...
2	Diaphragm	DD00...
18	Stud bolts	SD00S30
19	Flange nuts	

## 15.2 Valve disassembly (removing the actuator from the body)

### ⚠ WARNING



#### Risk of crushing due to moving parts when the valve is not installed!

- ▶ Upper limbs may get into the valve body openings while working on the valve.
- Ensure that the valve is in the respective end position (closed for NC or open for NO).
- Do not reach into the crushing area through the valve body openings.

### ⚠ CAUTION

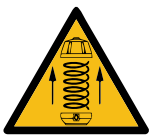

#### Actuator under spring pressure!

- ▶ Risk of injury due to flying components.
- Do not open the actuator.
- Return the actuator to GEMÜ for maintenance purposes.

1. Move the actuator **A** to the open position.
2. Remove the actuator **A** from the valve body **1**.

### NOTICE

- ▶ Clean all parts of contamination (do not damage the parts during cleaning) following removal. Check parts for potential damage, replace if necessary (only use genuine parts from GEMÜ).

## 15.3 Removing the diaphragm

### ⚠ CAUTION



#### Risk of injury due to moving parts when the valve is not installed!

- ▶ The valve spindle and diaphragm are moving parts that are moved with high force. This may lead to injuries when working on the valve.
- Watch out for moving parts when operating the actuator.
- Do not reach between the diaphragm, valve spindle and modified plant components.
- Have servicing and maintenance work carried out by trained personnel only.

### NOTICE

- ▶ The diaphragm is a wearing part and must be replaced with a new diaphragm after disassembly.

### NOTICE

- ▶ Before removing the diaphragm, please remove the actuator – see "Valve disassembly (removing the actuator from the body)".

1. Turn the diaphragm by 90° and pull it out.
2. Clean all parts so that they are free of remains of product and contaminants. Take care not to scratch or damage the parts in the process.
3. Check all parts for potential damage.
4. Replace damaged parts (only use genuine parts from GEMÜ).

## 15.4 Mounting the diaphragm

### 15.4.1 General information

### ⚠ WARNING



#### Hazardous media may escape if the diaphragm is faulty!

- ▶ Risk of injury due to contact with media that is harmful to health!
- Replace the diaphragms once they have reached their service life limits.
- Wear suitable protective gear while working on the product, depending on the working medium used.

### NOTICE

- ▶ Mount the correct diaphragm for the valve (suitable for medium, medium concentration, temperature and pressure). The shut-off diaphragm is a wearing part. Check the technical condition and function of the valve prior to commissioning and during the entire term of use. Carry out checks regularly and determine the check intervals in accordance with the conditions of use and/or the regulatory codes and provisions applicable for this application.

### NOTICE

- ▶ An incorrectly mounted diaphragm may cause valve leakage/emission of medium. In this case, remove the diaphragm, check the complete valve and diaphragms, and reassemble again.

### 15.4.2 Mounting the diaphragm

### NOTICE

- ▶ Moving parts when the drive is open. Watch out for moving parts when clocking the actuator.

1. Move the actuator **A** to the closed position.
2. Check whether the compressor is resting in the guides.

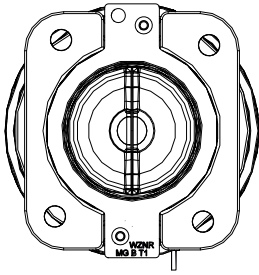

3. Press the pin of the new diaphragm into the compressor by hand, and then twist it by hand through 90° with little force.
4. Check whether the diaphragm boss is in the recess of the compressor.
5. Check the alignment of the diaphragm lug with the recess in the distance piece.

**15.5 Mounting the actuator on the valve body**

1. Move the actuator **A** to the open position.
2. Place the actuator **A** with the mounted diaphragm on the valve body **1**.  
⇒ Take care to align the compressor weir and valve body weir.
3. Tighten the flange nuts diagonally in several turns on the stud bolts of the valve body until the valve body and distance piece are seated without any gaps.

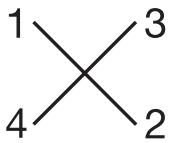

**Tightening torque guide value:**

Diaphragm size	Tightening torque
B	4.2 Nm
C	20.0 Nm

4. Move the actuator **A** to the closed position.
5. Check the fully assembled valve for leaks.

**16 Removal from piping**

1. Deactivate the control medium.
2. Disconnect the control medium line(s).
3. Disassemble the product. Observe warning notes and safety information.

**17 Disposal**

1. Pay attention to adhered residual material and gas diffusion from penetrated media.
2. Dispose of all parts in accordance with the disposal regulations/environmental protection laws.

**18 Returns**

Legal regulations for the protection of the environment and personnel require that the completed and signed return delivery note is included with the dispatch documents. Returned goods can be processed only when this note is completed. If no return delivery note is included with the product, GEMÜ cannot process credits or repair work but will dispose of the goods at the operator's expense.

1. Clean the product.
2. Request a return delivery note from GEMÜ.
3. Complete the return delivery note.
4. Send the product with a completed return delivery note to GEMÜ.

## 19 EU Declaration of Incorporation

Version 1.0

**GEMÜ**

## Original EU-Einbauerklärung

### EU Declaration of Incorporation

Wir, die Firma

We, the company

GEMÜ Gebr. Müller Apparatebau GmbH & Co. KG  
Fritz-Müller-Straße 6-8  
74653 Ingelfingen  
Deutschland

erklären hiermit in alleiniger Verantwortung, dass die nachfolgend bezeichneten Produkte den Vorschriften der genannten Richtlinien entspricht.

hereby declare under our sole responsibility that the below-mentioned products complies with the regulations of the mentioned Directives.

**Produkt:** GEMÜ D40**Product:** GEMÜ D40**Produktname:** Pneumatisch betätigtes Membranventil**Product name:** Pneumatically operated diaphragm valve

Die unvollständige Maschine darf erst dann in Betrieb genommen werden, wenn gegebenenfalls festgestellt wurde, dass die Maschine, in die die unvollständige Maschine eingebaut werden soll, den Bestimmungen der Maschinenrichtlinie 2006/42/EG entspricht.

The partly completed machinery may be commissioned only if it has been determined, if necessary, that the machinery into which the partly completed machinery is to be installed meets the provisions of the Machinery Directive 2006/42/EC.

**Richtlinien:****Guidelines:**MD 2006/42/EG<sup>1)</sup>

**Folgende harmonisierte Normen (oder Teile hieraus) wurden angewandt:**

**The following harmonized standards (or parts thereof) have been applied:**

EN ISO 12100:2010

**Folgende grundlegenden Sicherheits- und Gesundheitsschutzanforderungen der EG-Maschinenrichtlinie 2006/42/EG, Anhang I wurden angewandt und eingehalten:**

**The following essential health and safety requirements of the EC Machinery Directive 2006/42/EC, Annex I have been applied or adhered to:**

1.1.2.; 1.1.3.; 1.1.5.; 1.3.2.; 1.3.4.; 1.3.7.; 1.5.3.; 1.5.4.; 1.5.5.; 1.6.1.; 1.6.3.; 1.6.4.; 1.6.5.; 1.7.1.; 1.7.1.1.; 1.7.2.; 1.7.3.; 1.7.4.; 1.7.4.1.; 1.7.4.2.; 1.7.4.3.; 2.1.1.; 2.1.2.

<sup>1)</sup> MD 2006/42/EG**Bemerkungen:**

Ferner wird erklärt, dass die speziellen technischen Unterlagen gemäß Anhang VII Teil B erstellt wurden. Der Hersteller verpflichtet sich, einzelstaatlichen Stellen auf begründetes Verlangen die speziellen technischen Unterlagen zu der unvollständigen Maschine zu übermitteln. Diese Übermittlung erfolgt elektronisch. Die gewerblichen Schutzrechte bleiben hiervon unberührt!

<sup>1)</sup> MD 2006/42/EG**Remarks:**

We also declare that the specific technical documents have been created in accordance with part B of Annex VII. The manufacturer undertakes to transmit relevant technical documents on the partly completed machinery to the national authorities in response to a reasoned request. This communication takes place electronically. This does not affect the industrial property rights.



i.V. M. Barghoorn  
Leiter Globale Technik

Ingelfingen, 21.03.2025

GEMÜ Gebr. Müller Apparatebau GmbH & Co. KG  
Fritz-Müller-Straße 6-8, 74653 Ingelfingen, Deutschland

www.gemu-group.com  
info@gemu.de

## 20 EU Declaration of Conformity



Version 1.0



### EU-Konformitätserklärung EU Declaration of Conformity

Wir, die Firma

We, the company

GEMÜ Gebr. Müller Apparatebau GmbH & Co. KG  
Fritz-Müller-Straße 6-8  
74653 Ingelfingen  
Deutschland

erklären hiermit in alleiniger Verantwortung, dass die nachfolgend bezeichneten Produkte den Vorschriften der genannten Richtlinien entspricht.

hereby declare under our sole responsibility that the below-mentioned products complies with the regulations of the mentioned Directives.

**Produkt:** GEMÜ D40

**Product:** GEMÜ D40

**Produktname:** Pneumatisch betätigtes Membranventil

**Product name:** Pneumatically operated diaphragm valve

**Richtlinien:**

**Guidelines:**

PED 2014/68/EU<sup>1)</sup>

**Folgende harmonisierte Normen (oder Teile hieraus) wurden angewandt:**

**The following harmonized standards (or parts thereof) have been applied:**

EN 13397:2001

<sup>1)</sup> PED 2014/68/EU

**Benannte Stelle:**  
TÜV Rheinland Industrie Service GmbH  
Am Grauen Stein 1  
51105 Köln

**Kennnummer der benannten Stelle:** 0035

**Nr. des QS-Zertifikats:** 01 202 926/Q-02 0036

**Angewandte(s) Konformitätsbewertungsverfahren:** Modul H

**Hinweis für Produkte mit einer Nennweite ≤ DN 25:**

Die Produkte werden entwickelt und produziert nach GEMÜ eigenen Verfahrensweisungen und Qualitätsstandards, welche die Forderungen der ISO 9001 und der ISO 14001 erfüllen. Die Produkte dürfen gemäß Artikel 4, Absatz 3 der Druckgeräterichtlinie 2014/68/EU keine CE-Kennzeichnung tragen.

**Bemerkungen:**

Der Einsatz des Produkts in Kategorie III gemäß Druckgeräterichtlinie 2014/68/EU sowie die Verwendung mit instabilen Gasen ist nicht zulässig.

<sup>1)</sup> PED 2014/68/EU

**Notified body:**  
TÜV Rheinland Industrie Service GmbH  
Am Grauen Stein 1  
51105 Cologne, Germany

**ID number of the notified body:** 0035

**No. of the QA certificate:** 01 202 926/Q-02 0036

**Conformity assessment procedure(s) applied:** Module H

**Information for products with a nominal size ≤ DN 25:**

The products are developed and produced according to GEMÜ's in-house process instructions and standards of quality which comply with the requirements of ISO 9001 and ISO 14001. According to Article 4, Paragraph 3 of the Pressure Equipment Directive 2014/68/EU, these products must not be identified by a CE-marking.

**Remarks:**

Use of the product in category III in accordance with Pressure Equipment Directive 2014/68/EU and use with unstable gases are not permissible.

i.v. M. Barghoorn  
Leiter Globale Technik

Ingelfingen, 21.03.2025

GEMÜ Gebr. Müller Apparatebau GmbH & Co. KG  
Fritz-Müller-Straße 6-8, 74653 Ingelfingen, Deutschland

www.gemu-group.com  
info@gemu.de

## 21 EU Declaration of Conformity

Version 1

**GEMÜ****EU-Konformitätserklärung**  
**EU Declaration of Conformity**

Wir, die Firma

We, the company

GEMÜ Gebr. Müller Apparatebau GmbH & Co. KG  
Gert-Müller-Platz 1  
74635 Kupferzell  
Deutschland

erklären hiermit in alleiniger Verantwortung, dass die nachfolgend bezeichneten Produkte den Vorschriften der genannten Richtlinien entspricht.

hereby declare under our sole responsibility that the below-mentioned products complies with the regulations of the mentioned Directives.

**Produkt:** GEMÜ D40 Sonderausführung Code X**Product:** GEMÜ D40 special version Code X**Produktname:** Pneumatisch betätigtes Membranventil**Product name:** Pneumatically operated diaphragm valve**Richtlinien/Verordnungen:****Directives/Regulations:**ATEX 2014/34/EU<sup>1)</sup>**Folgende harmonisierte Normen (oder Teile hieraus) wurden angewandt:****The following harmonized standards (or parts thereof) have been applied:**

EN IEC 80079-36 Berichtigung 1:2024; EN IEC 80079-36:2016; EN IEC 80079-37:2016

<sup>1)</sup> ATEX 2014/34/EU**Dokumente hinterlegt bei:**

IBEXU Institut für Sicherheitstechnik GmbH

**Dokumente hinterlegt unter:** 211/06\_E1 bzw. IB2066180**Explosionsschutzkennung:** Gas:  II 2 G Ex h IIC T6 ... T3 Gb X**Explosionsschutzkennung:** Staub:  II -/2 D Ex h -/IIIC T150 °C -/Db X<sup>1)</sup> ATEX 2014/34/EU**Documents filed with:**

IBEXU Institut für Sicherheitstechnik GmbH

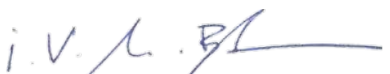
**Documents filed under:** 211/06\_E1 bzw. IB2066180**Explosion protection designation:** Gas:  II 2 G Ex h IIC T6 ... T3 Gb X**Explosion protection designation:** Dust:  II -/2 D Ex h -/IIIC T150 °C -/Db Xi.V. M. Barghoorn  
Leiter Globale Technik  
Ingelfingen, 27.11.2025GEMÜ Gebr. Müller Apparatebau GmbH & Co. KG  
Fritz-Müller-Straße 6-8, 74653 Ingelfingen, Deutschlandwww.gemu-group.com  
info@gemue.de



GEMÜ Gebr. Müller Apparatebau GmbH & Co. KG  
Gert-Müller-Platz 1, 74635 Kupferzell, Germany  
Phone +49 (0) 7940 1230 · info@gemue.de  
www.gemu-group.com

Subject to alteration

06.2026 | 88922898