

## GEMÜ 650TL

### Manually operated diaphragm valve



#### Features

- Fail safe function (closed)
- Proximity switches can be fitted for recording the valve position
- CIP/SIP capable
- Closing stroke limiter (MG 8)
- Opening and closing stroke limiter (MG 10 + 25)

#### Description

Diaphragm valve GEMÜ 650TL is a manually operated diaphragm valve with a pneumatic fail safe function. The valve can only be operated manually (opened/closed) if the actuator is supplied with compressed air. If this supply is interrupted, the valve closes due to the force of the spring and can no longer be opened manually.

#### Technical specifications

- **Media temperature :** -10 to 100 °C
- **Sterilization temperature:** Max. 150 °C
- **Ambient temperature:** 0 to 60 °C
- **Operating pressure :** 0 to 10 bar
- **Nominal sizes:** DN 4 to 25
- **Body configurations:** i-body | Multi-port body | Straight through body | T body | Tank valve body | Welding configuration
- **Connection types:** Clamp | Flange | Spigot | thread
- **Connection standards :** ANSI | ASME | BS | DIN | EN | ISO | JIS | SMS
- **Body materials:** (316L), forging material | 1.4435 (316L), block material | 1.4435 (BN2), block material | 1.4435 (BN2), forged material | 1.4435, investment casting material | 1.4539 (904L), forged material
- **Diaphragm materials:** EPDM | PTFE/EPDM
- **Conformities:** 3A | CRN | EAC | FDA | Oxygen | Reg. (EU) No. 10/2011 | Regulation (EC) No. 1935/2004 | Regulation (EC) No. 2023/2006 | TA Luft (German Clean Air Act) | USP

Technical data depends on the respective configuration



further information  
webcode: GW-650TL



## Product description

### Construction

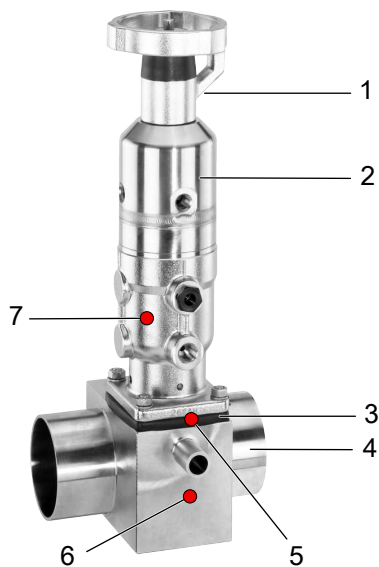

| Item | Name   | Materials  |
|------|--|--|
| 1    | Handwheel  | Stainless steel  |
| 2    | Membrane actuator                                      | Stainless steel  |
| 3    | Diaphragm  | EPDM<br>PTFE/EPDM (one-piece, two-piece)   |
| 4    | Valve body   | 1.4408, investment casting<br>1.4408, PFA lined<br>1.4435, investment casting<br>1.4435 (F316L), forged body<br>1.4435 (F316L), block material<br>1.4435 (BN2), forged body, $\Delta Fe < 0.5\%$<br>1.4435 (BN2), block material, $\Delta Fe < 0.5\%$<br>1.4539, forged body |
| 5    | CONEXO diaphragm RFID chip<br>(see Conexo information) |  |
| 6    | CONEXO body RFID chip<br>(see Conexo information)      |  |
| 7    | CONEXO actuator RFID chip<br>(see Conexo information)  |  |

## GEMÜ CONEXO

The interaction of valve components that are equipped with RFID chips and an associated IT infrastructure actively increase process reliability.



Thanks to serialization, every valve and every relevant valve component such as the body, actuator or diaphragm, and even automation components, can be clearly traced and read using the CONEXO pen RFID reader. The CONEXO app, which can be installed on mobile devices, not only facilitates and improves the "installation qualification" process, but also makes the maintenance process much more transparent and easier to document. The app actively guides the maintenance technician through the maintenance schedule and directly provides him with all the information assigned to the valve, such as test reports, testing documentation and maintenance histories. The CONEXO portal acts as a central element, helping to collect, manage and process all data.

**For further information on GEMÜ CONEXO please visit:**

[www.gemu-group.com/conexo](http://www.gemu-group.com/conexo)

### Ordering

GEMÜ Conexo must be ordered separately with the ordering option "CONEXO".

## Availabilities

### Availability of grades of surface finish

#### Internal surface finishes for forged and block material bodies <sup>1)</sup>

| Process contact surfaces   | Mechanically polished <sup>2)</sup> |      | Electropolished         |      |
|----------------------------|-------------------------------------|------|-------------------------|------|
|                            | Hygiene class DIN 11866             | Code | Hygiene class DIN 11866 | Code |
| Ra ≤ 0.80 µm               | H3                                  | 1502 | HE3                     | 1503 |
| Ra ≤ 0.60 µm               | -                                   | 1507 | -                       | 1508 |
| Ra ≤ 0.40 µm               | H4                                  | 1536 | HE4                     | 1537 |
| Ra ≤ 0.25 µm <sup>3)</sup> | H5                                  | 1527 | HE5                     | 1516 |

| Media wetted internal surface finishes in accordance with ASME BPE 2016 <sup>4)</sup> | Mechanically polished <sup>2)</sup> |      | Electropolished              |      |
|---|-------------------------------------|------|------------------------------|------|
|   | ASME BPE surface designation        | Code | ASME BPE surface designation | Code |
| Ra max. = 0.76 µm (30 µinch)  | SF3                                 | SF3  | -                            | -    |
| Ra max. = 0.64 µm (25 µinch)  | SF2                                 | SF2  | SF6                          | SF6  |
| Ra max. = 0.51 µm (20 µinch)  | SF1                                 | SF1  | SF5                          | SF5  |
| Ra max. = 0.38 µm (15 µinch)  | -                                   | -    | SF4                          | SF4  |

#### Internal surface finishes for investment cast bodies

| Process contact surfaces   | Mechanically polished <sup>2)</sup> |      |
|----------------------------|-------------------------------------|------|
|                            | Hygiene class DIN 11866             | Code |
| Ra ≤ 6.30 µm               | -                                   | 1500 |
| Ra ≤ 0.80 µm               | H3                                  | 1502 |
| Ra ≤ 0.60 µm <sup>5)</sup> | -                                   | 1507 |

Ra acc. to DIN EN ISO 4288 and ASME B46.1

- 1) Surface finishes of customized valve bodies may be limited in special cases.
- 2) Or any other finishing method that meets the Ra value (acc. to ASME BPE).
- 3) The smallest possible Ra finish for pipe connections with an internal pipe diameter < 6 mm is 0.38 µm.
- 4) When using these surfaces, the bodies are marked according to the specifications of ASME BPE.  
The surfaces are only available for valve bodies which are made of materials (e.g. GEMÜ material codes 40, 41, F4, 44)) and use connections (e.g. GEMÜ connection codes 59, 80, 88) according to ASME BPE.
- 5) Not possible for GEMÜ connection code 59, DN 8 and GEMÜ connection code 0, DN 4.

## Availability of valve bodies

### Spigot

| MG | DN | Connection type code <sup>1)</sup> |                  |                  |    |                  |                  |                  |                  |                  |    |                  |                  |    |                  |    |                  |                  |                  |                  |                  |                  |                  |                  |   |    |  |
|----|----|------------------------------------|------------------|------------------|----|------------------|------------------|------------------|------------------|------------------|----|------------------|------------------|----|------------------|----|------------------|------------------|------------------|------------------|------------------|------------------|------------------|------------------|---|----|--|
|    |    | 0                                  |                  | 16               |    | 17               |                  | 18               |                  | 35               |    | 36               |                  | 37 |                  | 55 |                  | 59               |                  | 60               |                  | 63               |                  | 64               |   | 65 |  |
|    |    | Material code <sup>2)</sup>        |                  |                  |    |                  |                  |                  |                  |                  |    |                  |                  |    |                  |    |                  |                  |                  |                  |                  |                  |                  |                  |   |    |  |
|    |    | C3                                 | 40,<br>42,<br>F4 | 40,<br>42,<br>F4 | C3 | 40,<br>42,<br>F4 | 40,<br>42,<br>F4 | 40,<br>42,<br>F4 | 40,<br>42,<br>F4 | 40,<br>42,<br>F4 | C3 | 40,<br>42,<br>F4 | 40,<br>42,<br>F4 | C3 | 40,<br>42,<br>F4 | C3 | 40,<br>42,<br>F4 | 40,<br>42,<br>F4 | 40,<br>42,<br>F4 | 40,<br>42,<br>F4 | 40,<br>42,<br>F4 | 40,<br>42,<br>F4 | 40,<br>42,<br>F4 | 40,<br>42,<br>F4 |   |    |  |
| 8  | 4  | X                                  | X                | -                | -  | -                | -                | -                | -                | -                | -  | -                | -                | -  | -                | -  | -                | -                | -                | -                | -                | -                | -                | -                | - |    |  |
|    | 6  | -                                  | -                | -                | X  | X                | -                | -                | X                | -                | -  | -                | -                | -  | -                | -  | X                | X                | -                | X                | -                | X                | -                | X                | - |    |  |
|    | 8  | -                                  | -                | -                | X  | X                | -                | -                | X                | -                | -  | X                | X                | X  | X                | X  | X                | X                | -                | X                | -                | X                | -                | X                | - |    |  |
|    | 10 | -                                  | -                | X                | X  | X                | X                | -                | -                | -                | -  | X                | X                | X  | -                | -  | -                | -                | -                | -                | -                | -                | -                | -                | - |    |  |
|    | 15 | -                                  | -                | -                | -  | -                | -                | -                | -                | -                | -  | X                | X                | X  | -                | -  | -                | -                | -                | -                | -                | -                | -                | -                | - |    |  |
| 10 | 10 | -                                  | -                | X                | X  | X                | X                | -                | X                | -                | -  | X                | -                | X  | X                | X  | X                | X                | -                | X                | -                | X                | -                | X                | - |    |  |
|    | 15 | -                                  | X                | X                | X  | X                | X                | -                | X                | -                | -  | X                | -                | X  | X                | X  | X                | X                | X                | X                | X                | X                | X                | X                | X |    |  |
|    | 20 | -                                  | -                | -                | -  | -                | -                | -                | -                | -                | -  | X                | X                | X  | -                | -  | -                | -                | -                | -                | -                | -                | -                | -                | - |    |  |
| 25 | 15 | -                                  | X                | X                | X  | X                | X                | -                | X                | -                | -  | -                | -                | -  | X                | X  | X                | X                | X                | X                | X                | X                | X                | X                | X |    |  |
|    | 20 | -                                  | X                | X                | X  | X                | X                | -                | X                | -                | -  | X                | X                | X  | X                | X  | X                | X                | X                | X                | X                | X                | X                | X                | X |    |  |
|    | 25 | -                                  | X                | X                | X  | X                | X                | X                | X                | X                | X  | -                | X                | X  | X                | X  | X                | X                | X                | X                | X                | X                | X                | X                | X |    |  |

MG = diaphragm size

X = Standard

#### 1) Connection type

Code 0: Spigot DIN

Code 16: Spigot DIN EN 10357 series B (2014 edition; formerly DIN 11850 series 1)

Code 17: Spigot EN 10357 series A/DIN 11866 series A, formerly DIN 11850 series 2

Code 18: Spigot DIN 11850 series 3

Code 35: Spigot JIS-G 3447

Code 36: Spigot JIS-G 3459 schedule 10s

Code 37: Spigot SMS 3008

Code 55: Spigot BS 4825, Part 1

Code 59: Spigot ASME BPE/DIN EN 10357 series C (from 2022 issue)/DIN 11866 series C

Code 60: Spigot ISO 1127/DIN EN 10357 series C (2014 issue)/DIN 11866 series B

Code 63: Spigot ANSI/ASME B36.19M schedule 10s

Code 64: Spigot ANSI/ASME B36.19M schedule 5s

Code 65: Spigot ANSI/ASME B36.19M schedule 40s

#### 2) Valve body material

Code 40: 1.4435 (F316L), forged body

Code 42: 1.4435 (BN2), forged body, Δ Fe < 0.5%

Code C3: 1.4435, investment casting

Code F4: 1.4539 / UNS N08904, forged body

**Threaded connection**

| MG | DN | Connection type code <sup>1)</sup> |  |
|----|----|------------------------------------|--|
|    |    | 6, 6K                              |  |
|    |    | Material code <sup>2)</sup>        |  |
|    |    | 40, 42                             |  |
| 8  | 8  | -                                  |  |
|    | 10 | W                                  |  |
| 10 | 10 | W                                  |  |
|    | 12 | -                                  |  |
|    | 15 | W                                  |  |
| 25 | 15 | W                                  |  |
|    | 20 | W                                  |  |
|    | 25 | W                                  |  |

MG = diaphragm size  
W = welded assembly

- 1) **Connection type**  
Code 6: Threaded spigot DIN 11851  
Code 6K: Cone spigot and union nut DIN 11851
- 2) **Valve body material**  
Code 40: 1.4435 (F316L), forged body  
Code 42: 1.4435 (BN2), forged body, Δ Fe < 0.5%

**Flange**

| Diaphragm size | DN | Connection type code <sup>1)</sup> |    |        |    |    |    |        |
|----------------|----|------------------------------------|----|--------|----|----|----|--------|
|                |    | 8                                  |    |        | 38 | 39 |    |        |
|                |    | Material code <sup>2)</sup>        |    |        |    |    |    |        |
|                |    | C3                                 | 39 | 40, 42 | 39 | C3 | 39 | 40, 42 |
| 25             | 15 | W                                  | X  | W      | -  | W  | X  | W      |
|                | 20 | W                                  | X  | W      | X  | W  | X  | W      |
|                | 25 | W                                  | X  | W      | X  | W  | X  | W      |

MG = diaphragm size  
X = Standard  
W = welded assembly

- 1) **Connection type**  
Code 8: Flange EN 1092, PN 16, form B, face-to-face dimension FTF EN 558 series 1, ISO 5752, basic series 1, length only for body configuration D  
Code 38: Flange ANSI Class 150 RF, face-to-face dimension FTF MSS SP-88, length only for body configuration D  
Code 39: Flange ANSI Class 125/150 RF, face-to-face dimension FTF EN 558 series 1, ISO 5752, basic series 1, length only for body configuration D
- 2) **Valve body material**  
Code 39: 1.4408, PFA lined  
Code 40: 1.4435 (F316L), forged body  
Code 42: 1.4435 (BN2), forged body, Δ Fe < 0.5%  
Code C3: 1.4435, investment casting

**Clamp**

| MG         | DN | Connection type code <sup>1)</sup> |    |    |    |    |    |    |
|------------|----|------------------------------------|----|----|----|----|----|----|
|            |    | 80                                 | 82 | 88 | 8A | 8E | 8P | 8T |
|            |    | Material code <sup>2)</sup>        |    |    |    |    |    |    |
| 40, 42, F4 |    |                                    |    |    |    |    |    |    |
| 8          | 6  | -                                  | K  | -  | K  | -  | -  | -  |
|            | 8  | K                                  | K  | -  | K  | -  | K  | -  |
|            | 10 | K                                  | -  | -  | W  | -  | K  | -  |
|            | 15 | K                                  | -  | W  | -  | -  | K  | W  |
| 10         | 10 | -                                  | K  | -  | K  | -  | -  | -  |
|            | 15 | K                                  | W  | K  | K  | -  | K  | K  |
|            | 20 | K                                  | -  | K  | -  | -  | K  | K  |
| 25         | 15 | -                                  | W  | -  | K  | -  | -  | -  |
|            | 20 | K                                  | K  | K  | K  | -  | K  | K  |
|            | 25 | K                                  | K  | K  | K  | K  | K  | K  |

MG = diaphragm size

K = connections completely machined (not welded)

W = welded assembly

**1) Connection type**

Code 80: Clamp ASME BPE, face-to-face dimension FTF ASME BPE, length only for body configuration D

Code 82: Clamp DIN 32676 series B, face-to-face dimension FTF EN 558 series 7, length only for body configuration D

Code 88: Clamp ASME BPE, for pipe ASME BPE, face-to-face dimension FTF EN 558 series 7, length only for body configuration D

Code 8A: Clamp DIN 32676 series A, face-to-face dimension FTF acc. to EN 558 series 7, length only for body configuration D

Code 8E: Clamp ISO 2852 for pipe ISO 2037, clamps SMS 3017 for pipe SMS 3008, face-to-face dimension FTF EN 558 series 7, length only for body configuration D

Code 8P: Clamp DIN 32676 series C, face-to-face dimension FTF ASME BPE, length only for body configuration D

Code 8T: Clamp DIN 32676 series C, face-to-face dimension FTF EN 558 series 7, length only for body configuration D

**2) Valve body material**

Code 40: 1.4435 (F316L), forged body

Code 42: 1.4435 (BN2), forged body, Δ Fe < 0.5%

Code F4: 1.4539 / UNS N08904, forged body

**Availability of product conformity**

| Foodstuff | Diaphragm material code <sup>1)</sup> |
|-----------|---------------------------------------|
| 3A        | 54, 5M                                |

Code 54 only for diaphragm size 8, 10

Code 5M only for diaphragm size 10, 25

**1) Diaphragm material**

Code 54: PTFE/EPDM one-piece

Code 5M: PTFE/EPDM two-piece

## Order data

### Order codes

| 1 Type   | Code |
|--|------|
| Diaphragm valve, pneumatically operated, stainless steel piston actuator electropolished, optical position indicator | 650  |

| 2 DN  | Code |
|-------|------|
| DN 4  | 4    |
| DN 6  | 6    |
| DN 8  | 8    |
| DN 10 | 10   |
| DN 15 | 15   |
| DN 20 | 20   |
| DN 25 | 25   |

| 3 Body configuration   | Code |
|--|------|
| Tank bottom valve body                                       | B    |
| 2/2-way body   | D    |
| T body   | T    |
| Body configuration code B: Dimensions and designs on request |      |
| Body configuration code T: Dimensions on request             |      |

| 4 Connection type  | Code |
|--|------|
| <b>Spigot</b>  |      |
| Spigot DIN   | 0    |
| Spigot DIN EN 10357 series B (2014 edition; formerly DIN 11850 series 1)                                   | 16   |
| Spigot EN 10357 series A/DIN 11866 series A, formerly DIN 11850 series 2                                   | 17   |
| Spigot DIN 11850 series 3  | 18   |
| Spigot JIS-G 3447  | 35   |
| Spigot JIS-G 3459 schedule 10s   | 36   |
| Spigot SMS 3008  | 37   |
| Spigot BS 4825, Part 1   | 55   |
| Spigot ASME BPE/DIN EN 10357 series C (from 2022 issue)/DIN 11866 series C                                 | 59   |
| Spigot ISO 1127/DIN EN 10357 series C (2014 issue)/DIN 11866 series B                                      | 60   |
| Spigot ANSI/ASME B36.19M schedule 10s  | 63   |
| Spigot ANSI/ASME B36.19M schedule 5s   | 64   |
| Spigot ANSI/ASME B36.19M schedule 40s  | 65   |
| <b>Threaded connection</b>   |      |
| Threaded spigot DIN 11851  | 6    |
| Cone spigot and union nut DIN 11851  | 6K   |
| <b>Clamp</b>   |      |
| Clamp ASME BPE, face-to-face dimension FTF ASME BPE, length only for body configuration D                  | 80   |
| Clamp DIN 32676 series B, face-to-face dimension FTF EN 558 series 7, length only for body configuration D | 82   |

| 4 Connection type   | Code |
|---|------|
| Clamp ASME BPE, for pipe ASME BPE, face-to-face dimension FTF EN 558 series 7, length only for body configuration D                                   | 88   |
| Clamp DIN 32676 series A, face-to-face dimension FTF acc. to EN 558 series 7, length only for body configuration D                                    | 8A   |
| Clamp ISO 2852 for pipe ISO 2037, clamps SMS 3017 for pipe SMS 3008, face-to-face dimension FTF EN 558 series 7, length only for body configuration D | 8E   |
| Clamp DIN 32676 series C, face-to-face dimension FTF ASME BPE, length only for body configuration D   | 8P   |
| Clamp DIN 32676 series C, face-to-face dimension FTF EN 558 series 7, length only for body configuration D  | 8T   |

| 5 Valve body material                             | Code |
|---|------|
| 1.4408, PFA lined                                 | 39   |
| 1.4435 (F316L), forged body                       | 40   |
| 1.4435 (316L), block material                     | 41   |
| 1.4435 (BN2), forged body, $\Delta Fe < 0.5\%$    | 42   |
| 1.4435 (BN2), block material, $\Delta Fe < 0.5\%$ | 43   |
| 1.4435, investment casting                        | C3   |
| 1.4539 / UNS N08904, forged body                  | F4   |

| 6 Diaphragm material  | Code |
|---|------|
| EPDM  | 13   |
| EPDM  | 3A   |
| EPDM  | 17   |
| EPDM  | 19   |
| PTFE/EPDM one-piece   | 54   |
| PTFE/EPDM two-piece   | 5M   |
| <b>Note:</b> The PTFE/EPDM diaphragm (code 5M) is available from diaphragm size 10. |      |
| <b>Note:</b> The EPDM diaphragm (code 3A) is only available for diaphragm size 8.   |      |

| 7 Control function   | Code |
|----------------------|------|
| Normally closed (NC) | 1    |

| 8 Actuator version  | Code |
|---|------|
| <b>DN 4 - 15, diaphragm size 8</b>  |      |
| Manually operated with automatic closing function, control air connector and connections for proximity switches positioned 90° offset to flow direction | OLL  |
| Manually operated with automatic closing function, control air connector and connections for proximity switches positioned in-line with flow direction  | OTL  |

| 8 Actuator version   | Code |
|--|------|
| Manually operated with automatic closing function, control air connector positioned 90° offset to flow direction, connections for proximity switches in-line with flow direction | 0RL  |
| <b>DN 10–20, diaphragm size 10</b>   |      |
| Manually operated with automatic closing function, control air connector and connections for proximity switches positioned in-line with flow direction                           | 1HL  |
| Manually operated with automatic closing function, control air connector and connections for proximity switches positioned 90° offset to flow direction                          | 1LL  |
| Manually operated with automatic closing function, control air connector and connections for proximity switches positioned 90° offset to flow direction                          | 1ML  |
| Manually operated with automatic closing function, control air connector positioned 90° offset to flow direction, connections for proximity switches in-line with flow direction | 1RL  |
| Manually operated with automatic closing function, control air connector positioned 90° offset to flow direction, connections for proximity switches in-line with flow direction | 1SL  |
| Manually operated with automatic closing function, control air connector and connections for proximity switches positioned in-line with flow direction                           | 1TL  |
| <b>DN 15 - 25, diaphragm size 25</b>   |      |
| Manually operated with automatic closing function, control air connector and connections for proximity switches positioned in-line with flow direction                           | 2HL  |
| Manually operated with automatic closing function, control air connector and connections for proximity switches positioned 90° offset to flow direction                          | 2LL  |
| Manually operated with automatic closing function, control air connector and connections for proximity switches positioned 90° offset to flow direction                          | 2ML  |
| Manually operated with automatic closing function, control air connector positioned 90° offset to flow direction, connections for proximity switches in-line with flow direction | 2RL  |
| Manually operated with automatic closing function, control air connector positioned 90° offset to flow direction, connections for proximity switches in-line with flow direction | 2SL  |
| Manually operated with automatic closing function, control air connector and connections for proximity switches positioned in-line with flow direction                           | 2TL  |
| 9 DN-2   | Code |
| DN 4   | 4    |

| 9 DN-2 | Code |
|--------|------|
| DN 6   | 6    |
| DN 8   | 8    |
| DN 10  | 10   |
| DN 15  | 15   |
| DN 20  | 20   |
| DN 25  | 25   |

| 10 Connection type for T body   | Code |
|---|------|
| <b>Spigot</b>   |      |
| Spigot DIN  | 0    |
| Spigot DIN EN 10357 series B (2014 edition; formerly DIN 11850 series 1)  | 16   |
| Spigot EN 10357 series A/DIN 11866 series A, formerly DIN 11850 series 2  | 17   |
| Spigot DIN 11850 series 3   | 18   |
| Spigot JIS-G 3447   | 35   |
| Spigot JIS-G 3459 schedule 10s  | 36   |
| Spigot SMS 3008   | 37   |
| Spigot BS 4825, Part 1  | 55   |
| Spigot ASME BPE/DIN EN 10357 series C (from 2022 issue)/DIN 11866 series C  | 59   |
| Spigot ISO 1127/DIN EN 10357 series C (2014 issue)/DIN 11866 series B   | 60   |
| Spigot ANSI/ASME B36.19M schedule 10s   | 63   |
| Spigot ANSI/ASME B36.19M schedule 5s  | 64   |
| Spigot ANSI/ASME B36.19M schedule 40s   | 65   |
| <b>Threaded connection</b>  |      |
| Threaded spigot DIN 11851   | 6    |
| Cone spigot and union nut DIN 11851   | 6K   |
| <b>Clamp</b>  |      |
| Clamp ASME BPE, face-to-face dimension FTF ASME BPE, length only for body configuration D   | 80   |
| Clamp DIN 32676 series B, face-to-face dimension FTF EN 558 series 7, length only for body configuration D  | 82   |
| Clamp ASME BPE, for pipe ASME BPE, face-to-face dimension FTF EN 558 series 7, length only for body configuration D                                   | 88   |
| Clamp DIN 32676 series A, face-to-face dimension FTF acc. to EN 558 series 7, length only for body configuration D                                    | 8A   |
| Clamp ISO 2852 for pipe ISO 2037, clamps SMS 3017 for pipe SMS 3008, face-to-face dimension FTF EN 558 series 7, length only for body configuration D | 8E   |
| Clamp DIN 32676 series C, face-to-face dimension FTF ASME BPE, length only for body configuration D   | 8P   |
| Clamp DIN 32676 series C, face-to-face dimension FTF EN 558 series 7, length only for body configuration D  | 8T   |

| 11 Surface  | Code |
|---|------|
| Ra ≤ 6.3 µm for media wetted surfaces, mechanically polished internal | 1500 |

## Order data

| 11 Surface  | Code |
|---|------|
| Ra ≤ 0.8 µm for media wetted surfaces, in accordance with DIN 11866 H3, mechanically polished internal  | 1502 |
| Ra ≤ 0.8 µm for media wetted surfaces, in accordance with DIN 11866 HE3, electropolished internal/external  | 1503 |
| Ra ≤ 0.6 µm for media wetted surfaces, mechanically polished internal   | 1507 |
| Ra ≤ 0.6 µm for media wetted surfaces, electropolished internal/external  | 1508 |
| Ra ≤ 0.25 µm for media wetted surfaces *), in accordance with DIN 11866 HE5, electropolished internal/external, *) for inner pipe diameter ≤ 6 mm, in spigot Ra ≤ 0.38 µm | 1516 |
| Ra ≤ 0.25 µm for media wetted surfaces *), in accordance with DIN 11866 H5, mechanically polished internal, *) for inner pipe diameter < 6 mm, in spigots Ra ≤ 0.38 µm    | 1527 |
| Ra ≤ 0.4 µm for media wetted surfaces, in accordance with DIN 11866 H4, mechanically polished internal  | 1536 |
| Ra ≤ 0.4 µm for media wetted surfaces, in accordance with DIN 11866 HE4, electropolished internal/external  | 1537 |
| Ra max. 0.51 µm (20 µin.) for media wetted surfaces, in accordance with ASME BPE SF1, mechanically polished internal  | SF1  |

| 11 Surface  | Code |
|---|------|
| Ra max. 0.64 µm (25 µin.) for media wetted surfaces, in accordance with ASME BPE SF2, mechanically polished internal    | SF2  |
| Ra max. 0.76 µm (30 µin.) for media wetted surfaces, in accordance with ASME BPE SF3, mechanically polished internal    | SF3  |
| Ra max. 0.38 (15 µin.) µm for media wetted surfaces, in accordance with ASME BPE SF4, electropolished internal/external | SF4  |
| Ra max. 0.51 µm (20 µin.) for media wetted surfaces, in accordance with ASME BPE SF5, electropolished internal/external | SF5  |
| Ra max. 0.64 µm (25 µin.) for media wetted surfaces, in accordance with ASME BPE SF6, electropolished internal/external | SF6  |

| 12 Special version  | Code |
|---|------|
| Without   |      |
| Special version for 3A  | M    |
| Special version for oxygen, maximum medium temperature: 60 °C | S    |

| 13 CONEXO   | Code |
|---|------|
| Without   |      |
| Integrated RFID chip for electronic identification and traceability | C    |

## Order example

| Ordering option               | Code | Description  |
|-------------------------------|------|--|
| 1 Type                        | 650  | Diaphragm valve, pneumatically operated, stainless steel piston actuator electropolished, optical position indicator   |
| 2 DN                          | 25   | DN 25  |
| 3 Body configuration          | T    | T body   |
| 4 Connection type             | 60   | Spigot ISO 1127/DIN EN 10357 series C (2014 issue)/DIN 11866 series B  |
| 5 Valve body material         | 41   | 1.4435 (316L), block material  |
| 6 Diaphragm material          | 17   | EPDM   |
| 7 Control function            | 1    | Normally closed (NC)   |
| 8 Actuator version            | 2SL  | Manually operated with automatic closing function, control air connector positioned 90° offset to flow direction, connections for proximity switches in-line with flow direction |
| 9 DN-2                        | 25   | DN 25  |
| 10 Connection type for T body | 60   | Spigot ISO 1127/DIN EN 10357 series C (2014 issue)/DIN 11866 series B  |
| 11 Surface                    | 1503 | Ra ≤ 0.8 µm for media wetted surfaces, in accordance with DIN 11866 HE3, electropolished internal/external   |
| 12 Special version            | M    | Special version for 3A   |
| 13 CONEXO                     |      | Without  |

## Technical data

### Medium

**Working medium:** Corrosive, inert, gaseous and liquid media which have no negative impact on the physical and chemical properties of the body and diaphragm material.

**Control medium:** Inert gases

### Temperature

**Media temperature:** -10 – 100 °C  
For special function S: 0 – 60 °C

**Sterilization temperature:**

|                     |   |
|---------------------|---|
| EPDM (code 3A/13)   | max. 150 °C, max. 60 min per cycle          |
| EPDM (code 17)      | max. 150 °C, max. 180 min per cycle         |
| EPDM (code 19)      | max. 150 °C, max. 180 min per cycle         |
| PTFE/EPDM (code 54) | max. 150 °C, constant temperature per cycle |
| PTFE/EPDM (code 5M) | max. 150 °C, constant temperature per cycle |

The sterilization temperature is only valid for steam (saturated steam) or superheated water. If the sterilization temperatures listed above are applied to the EPDM diaphragms for longer periods of time, the service life of the diaphragms will be reduced. In these cases, maintenance cycles must be adapted accordingly.

PTFE diaphragms can also be used as steam barriers; however, this will reduce their service life. This also applies to PTFE diaphragms exposed to high temperature fluctuations. The maintenance cycles must be adapted accordingly. GEMÜ 555 and 505 globe valves are particularly suitable for use in the area of steam generation and distribution. The following valve arrangement for interfaces between steam pipes and process pipes has proven itself over time: A globe valve for shutting off steam pipes and a diaphragm valve as an interface to the process pipes.

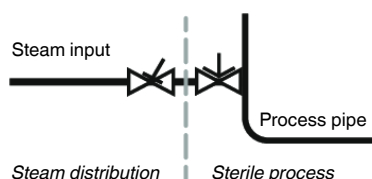

**Ambient temperature:** 0 – 60 °C

**Control medium temperature:** max. 60 °C

**Storage temperature:** 0 – 40 °C

### Pressure

**Operating pressure:**

| Actuator version | DN      | MG | Operating pressure |        |
|------------------|---------|----|--------------------|--------|
|                  |         |    | EPDM               | PTFE   |
| 0TL, 0RL, 0LL    | 4 - 15  | 8  | 0 - 8              | 0 - 6  |
| 1TL, 1RL, 1LL    | 10 - 20 | 10 | 0 - 5              | 0 - 5  |
| 1HL, 1ML, 1SL    |         |    | 0 - 10             | 0 - 10 |
| 2TL, 2RL, 2LL    | 15 - 25 | 25 | 0 - 5              | 0 - 5  |
| 2HL, 2ML, 2SL    |         |    | 0 - 10             | 0 - 10 |

All pressures are gauge pressures. Operating pressure values were determined with static operating pressure applied on one side of a closed valve. Sealing at the valve seat and atmospheric sealing is ensured for the given values.

Information on operating pressures applied on both sides and for high purity media on request.

**Control pressure:**

**Control function 1**

| Actuator version | DN      | MG | Control pressure |
|------------------|---------|----|------------------|
| 0TL, 0RL, 0LL    | 4 - 15  | 8  | 5.0 - 7.0        |
| 1TL, 1RL, 1LL    | 10 - 20 | 10 | 5.0 - 7.0        |
| 1HL, 1ML, 1SL    |         |    | 5.0 - 8.0        |
| 2TL, 2RL, 2LL    | 15 - 25 | 25 | 4.0 - 7.0        |
| 2HL, 2ML, 2SL    |         |    | 5.0 - 8.0        |

All pressures are gauge pressures.  
MG = diaphragm size

**Filling volume:**

**Control function 1**

| Actuator version                | DN      | MG | Filling volume [dm³] |
|---------------------------------|---------|----|----------------------|
| 0TL, 0RL, 0LL                   | 4 - 15  | 8  | 0.01                 |
| 1TL, 1RL, 1LL,<br>1HL, 1ML, 1SL | 10 - 20 | 10 | 0.02                 |
| 2TL, 2RL, 2LL,<br>2HL, 2ML, 2SL | 15 - 25 | 25 | 0.06                 |

**Product conformity**

**Pressure Equipment Directive:** 2014/68/EU

**Machinery Directive:** 2006/42/EC

**Food:** FDA  
Regulation (EC) No. 1935/2004  
Regulation (EC) No. 10/2011  
Regulation (EC) No. 2023/2006  
USP Class VI  
CRN  
\* depending on version and/or operating parameters

**Oxygen:** BAM compliant, the product is suitable for application with oxygen (special version code S)

**TA Luft (German Clean Air Act):** The product complies with the equivalence requirements of section 5.2.6.4 of the German Clean Air Act (TA Luft / VDI 2440 according to section 3.3.1.3)

**EAC:** The product is certified according to EAC.

**Mechanical data**

**Installation position:** Optional  
Observe the angle of rotation for optimized draining when it comes to installation. See separate document, "Angle of rotation technical information".

## Dimensions

### Actuator dimensions

#### Actuator version OTL, ORL, OLL

Actuator version OTL  
control air connector and connections  
for proximity switches  
positioned in-line with flow direction

Actuator version ORL  
control air connector positioned 90°  
offset to flow direction,  
connections for proximity switches  
positioned in-line with flow direction

Actuator version OLL  
control air connector and connections  
for proximity switches positioned 90°  
offset to flow direction

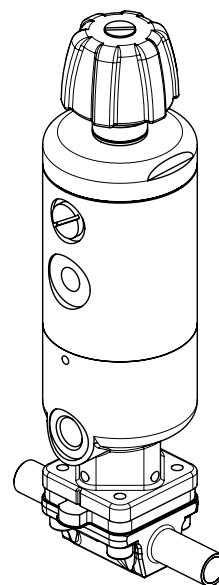
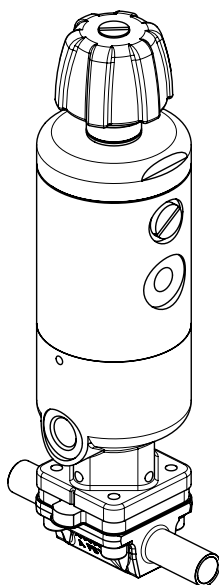
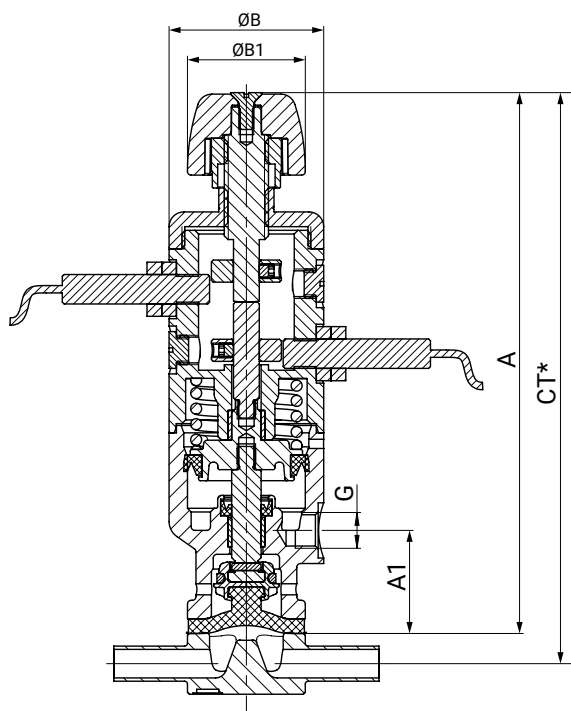

| Actuator version | MG | A     | A1   | A2 | ØB   | ØB1  | G     |
|------------------|----|-------|------|----|------|------|-------|
| O TL, O RL, O LL | 8  | 146.0 | 26.5 | -  | 42.0 | 32.0 | G 1/8 |

Dimensions in mm

MG = diaphragm size

\* CT = A + H1 (see body dimensions)

**Actuator version 1TL, 1HL, 1RL, 1SL, 1LL, 1ML**

Actuator version 1TL, 1HL  
control air connector and connections  
for proximity switches positioned in-line  
with flow direction

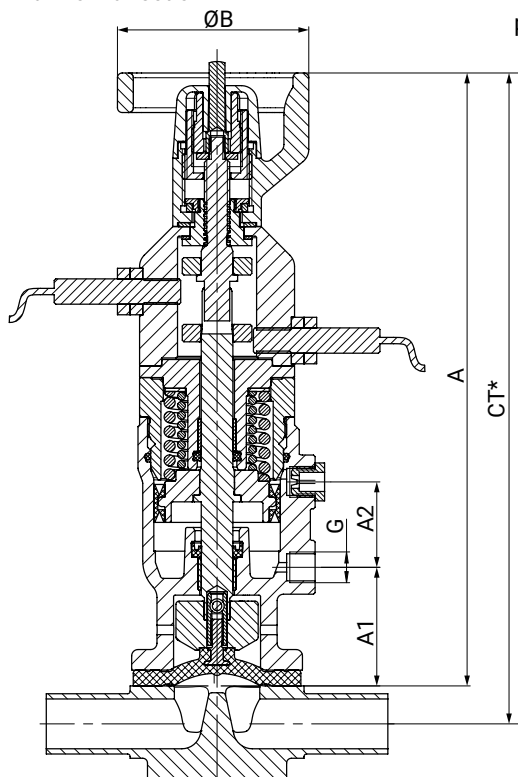

Actuator version 1RL, 1SL  
control air connector positioned 90°  
offset to flow direction,  
connections for proximity switches  
positioned in-line with flow direction

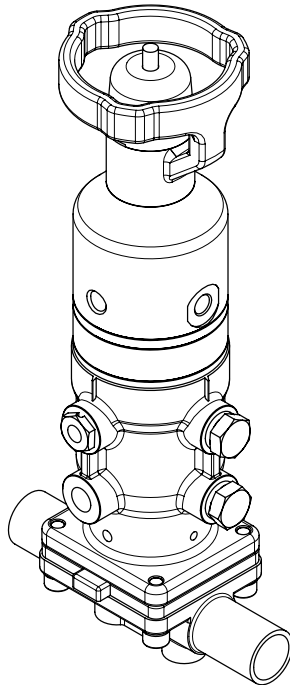

Actuator version 1LL, 1ML  
control air connector and connections  
for proximity switches positioned 90°  
offset to flow direction

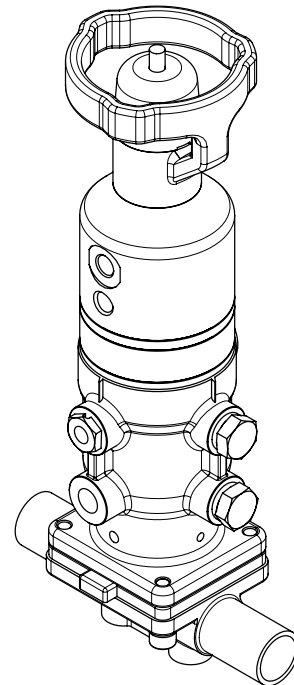

| Actuator version                        | MG        | A     | A1   | A2   | ØB   | ØB1 | G     |
|---|-----------|-------|------|------|------|-----|-------|
| <b>1TL, 1RL, 1LL,<br/>1HL, 1ML, 1SL</b> | <b>10</b> | 196.0 | 37.0 | 27.0 | 60.0 | -   | G 1/8 |

Dimensions in mm  
MG = diaphragm size  
\* CT = A + H1 (see body dimensions)

**Actuator version 2TL, 2HL, 2RL, 2SL, 2LL, 2ML**

Actuator version 2TL, 2HL  
Pilot air connection and connections for proximity switches in flow direction

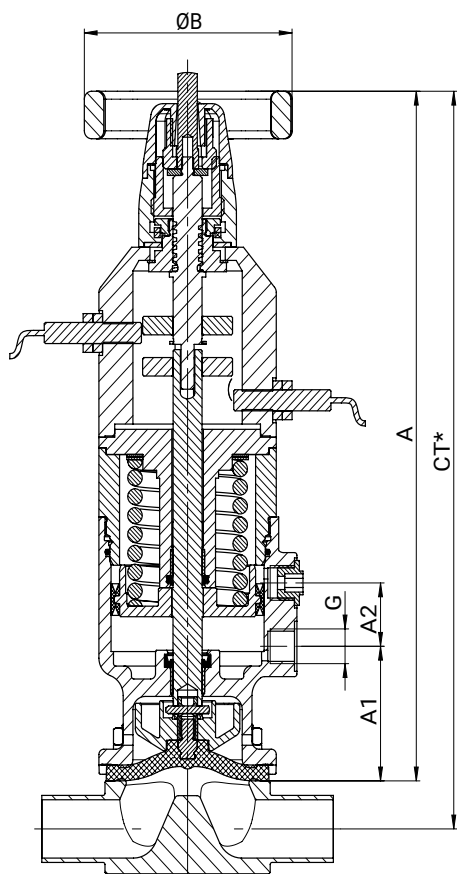

Actuator version 2RL, 2SL  
Pilot air connection 90° to the direction of flow,  
Connections for proximity switches in flow direction

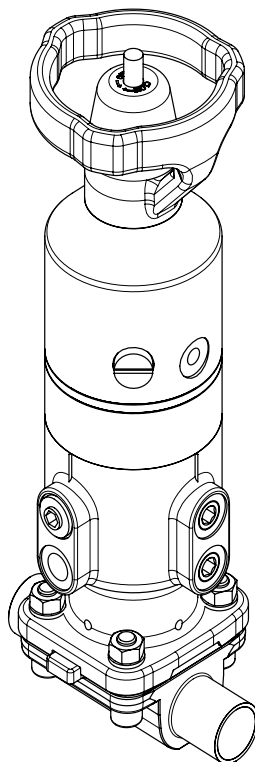

Actuator version 2LL, 2ML  
Control air connection and connections for proximity switches 90° to the flow direction

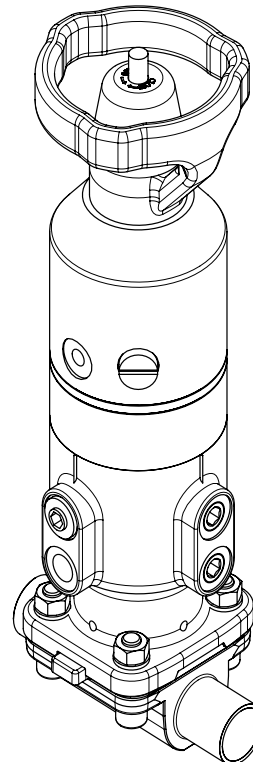

| Actuator version             | MG | A     | A1   | A2   | ØB   | ØB1 | G     |
|------------------------------|----|-------|------|------|------|-----|-------|
| 2TL, 2RL, 2LL, 2HL, 2ML, 2SL | 25 | 264.0 | 51.0 | 24.0 | 85.0 | -   | G 1/4 |

Dimensions in mm  
MG = diaphragm size  
\* CT = A + H1 (see body dimensions)

**Body dimensions of 2/2-way body**

**Spigot DIN/EN/ISO (code 0, 16, 17, 18, 60)**

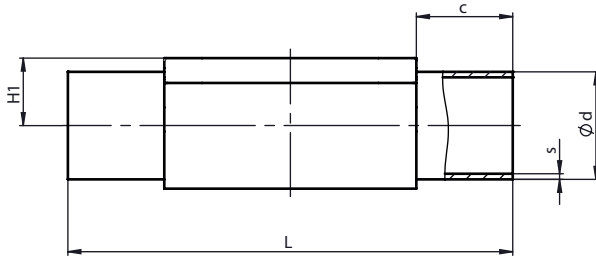

**Connection type spigot DIN/EN/ISO (code 0, 16, 17, 18, 60)<sup>1)</sup>, forged material (code 40, 42, F4)<sup>2)</sup>**

| MG | DN | NPS  | c (min) | Ød              |      |      |      |      | H1   | L     | s               |     |     |     |     |
|----|----|------|---------|-----------------|------|------|------|------|------|-------|-----------------|-----|-----|-----|-----|
|    |    |      |         | Connection type |      |      |      |      |      |       | Connection type |     |     |     |     |
|    |    |      |         | 0               | 16   | 17   | 18   | 60   |      |       | 0               | 16  | 17  | 18  | 60  |
| 8  | 4  | -    | 20.0    | 6.0             | -    | -    | -    | -    | 8.5  | 72.0  | 1.0             | -   | -   | -   | -   |
|    | 6  | -    | 20.0    | -               | -    | 8.0  | -    | 10.2 | 8.5  | 72.0  | -               | -   | 1.0 | -   | 1.6 |
|    | 8  | 1/4" | 20.0    | -               | -    | 10.0 | -    | 13.5 | 8.5  | 72.0  | -               | -   | 1.0 | -   | 1.6 |
|    | 10 | 3/8" | 20.0    | -               | 12.0 | 13.0 | 14.0 | -    | 8.5  | 72.0  | -               | 1.0 | 1.5 | 2.0 | -   |
| 10 | 10 | 3/8" | 25.0    | -               | 12.0 | 13.0 | 14.0 | 17.2 | 12.5 | 108.0 | -               | 1.0 | 1.5 | 2.0 | 1.6 |
|    | 15 | 1/2" | 25.0    | 18.0            | 18.0 | 19.0 | 20.0 | 21.3 | 12.5 | 108.0 | 1.5             | 1.0 | 1.5 | 2.0 | 1.6 |
| 25 | 15 | 1/2" | 25.0    | 18.0            | 18.0 | 19.0 | 20.0 | 21.3 | 19.0 | 120.0 | 1.5             | 1.0 | 1.5 | 2.0 | 1.6 |
|    | 20 | 3/4" | 25.0    | 22.0            | 22.0 | 23.0 | 24.0 | 26.9 | 19.0 | 120.0 | 1.5             | 1.0 | 1.5 | 2.0 | 1.6 |
|    | 25 | 1"   | 25.0    | 28.0            | 28.0 | 29.0 | 30.0 | 33.7 | 19.0 | 120.0 | 1.5             | 1.0 | 1.5 | 2.0 | 2.0 |

Dimensions in mm

MG = diaphragm size

1) **Connection type**

Code 0: Spigot DIN

Code 16: Spigot DIN EN 10357 series B (2014 edition; formerly DIN 11850 series 1)

Code 17: Spigot EN 10357 series A/DIN 11866 series A, formerly DIN 11850 series 2

Code 18: Spigot DIN 11850 series 3

Code 60: Spigot ISO 1127/DIN EN 10357 series C (2014 issue)/DIN 11866 series B

2) **Valve body material**

Code 40: 1.4435 (F316L), forged body

Code 42: 1.4435 (BN2), forged body, Δ Fe < 0.5%

Code F4: 1.4539 / UNS N08904, forged body

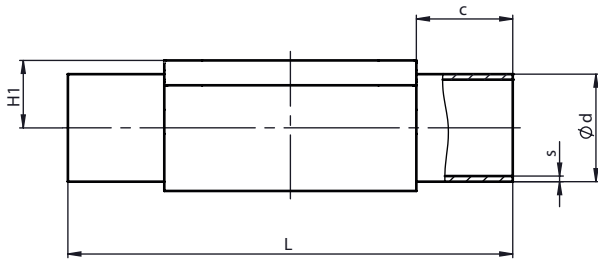

Connection type spigot DIN/EN/ISO (code 0, 17, 60)<sup>1)</sup>, investment casting material (code C3)<sup>2)</sup>

| MG | DN | NPS  | c (min) | ød              |      |      | H1   | L     | s               |     |     |
|----|----|------|---------|-----------------|------|------|------|-------|-----------------|-----|-----|
|    |    |      |         | Connection type |      |      |      |       | Connection type |     |     |
|    |    |      |         | 0               | 17   | 60   |      |       | 0               | 17  | 60  |
| 8  | 4  | -    | 20.0    | 6.0             | -    | -    | 8.5  | 72.0  | 1.0             | -   | -   |
|    | 6  | -    | 20.0    | -               | 8.0  | -    | 8.5  | 72.0  | -               | 1.0 | -   |
|    | 8  | 1/4" | 20.0    | -               | 10.0 | 13.5 | 8.5  | 72.0  | -               | 1.0 | 1.6 |
|    | 10 | 3/8" | 20.0    | -               | 13.0 | -    | 8.5  | 72.0  | -               | 1.5 | -   |
| 10 | 10 | 3/8" | 25.0    | -               | 13.0 | 17.2 | 12.5 | 108.0 | -               | 1.5 | 1.6 |
|    | 15 | 1/2" | 25.0    | -               | 19.0 | 21.3 | 12.5 | 108.0 | -               | 1.5 | 1.6 |
| 25 | 15 | 1/2" | 25.0    | -               | 19.0 | 21.3 | 13.0 | 120.0 | -               | 1.5 | 1.6 |
|    | 20 | 3/4" | 25.0    | -               | 23.0 | 26.9 | 16.0 | 120.0 | -               | 1.5 | 1.6 |
|    | 25 | 1"   | 25.0    | -               | 29.0 | 33.7 | 19.0 | 120.0 | -               | 1.5 | 2.0 |

Dimensions in mm

MG = diaphragm size

1) **Connection type**

Code 0: Spigot DIN

Code 17: Spigot EN 10357 series A/DIN 11866 series A, formerly DIN 11850 series 2

Code 60: Spigot ISO 1127/DIN EN 10357 series C (2014 issue)/DIN 11866 series B

2) **Valve body material**

Code C3: 1.4435, investment casting

**Spigot ASME/BS (code 55, 59, 63, 64, 65)**

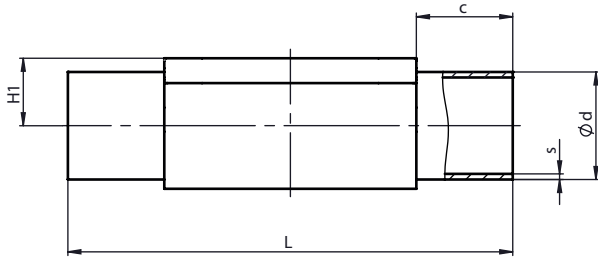

**Connection type spigot ASME/BS (code 55, 59, 63, 64, 65)<sup>1)</sup>, forged material (code 40, 42, F4)<sup>2)</sup>**

| MG | DN | NPS  | c (min) | Ød              |       |      |      |      | H1   | L     | s               |      |      |      |      |
|----|----|------|---------|-----------------|-------|------|------|------|------|-------|-----------------|------|------|------|------|
|    |    |      |         | Connection type |       |      |      |      |      |       | Connection type |      |      |      |      |
|    |    |      |         | 55              | 59    | 63   | 64   | 65   |      |       | 55              | 59   | 63   | 64   | 65   |
| 8  | 6  | -    | 20.0    | -               | -     | 10.3 | -    | 10.3 | 8.5  | 72.0  | -               | -    | 1.24 | -    | 1.73 |
|    | 8  | 1/4" | 20.0    | 6.35            | 6.35  | 13.7 | -    | 13.7 | 8.5  | 72.0  | 1.2             | 0.89 | 1.65 | -    | 2.24 |
|    | 10 | 3/8" | 20.0    | 9.53            | 9.53  | -    | -    | -    | 8.5  | 72.0  | 1.2             | 0.89 | -    | -    | -    |
|    | 15 | 1/2" | 20.0    | 12.70           | 12.70 | -    | -    | -    | 8.5  | 72.0  | 1.2             | 1.65 | -    | -    | -    |
| 10 | 10 | 3/8" | 25.0    | 9.53            | 9.53  | 17.1 | -    | 17.1 | 12.5 | 108.0 | 1.2             | 0.89 | 1.65 | -    | 2.31 |
|    | 15 | 1/2" | 25.0    | 12.70           | 12.70 | 21.3 | 21.3 | 21.3 | 12.5 | 108.0 | 1.2             | 1.65 | 2.11 | 1.65 | 2.77 |
|    | 20 | 3/4" | 25.0    | 19.05           | 19.05 | -    | -    | -    | 12.5 | 108.0 | 1.2             | 1.65 | -    | -    | -    |
| 25 | 15 | 1/2" | 25.0    | -               | -     | 21.3 | 21.3 | 21.3 | 19.0 | 120.0 | -               | -    | 2.11 | 1.65 | 2.77 |
|    | 20 | 3/4" | 25.0    | 19.05           | 19.05 | 26.7 | 26.7 | 26.7 | 19.0 | 120.0 | 1.2             | 1.65 | 2.11 | 1.65 | 2.87 |
|    | 25 | 1"   | 25.0    | -               | 25.40 | 33.4 | 33.4 | 33.4 | 19.0 | 120.0 | -               | 1.65 | 2.77 | 1.65 | 3.38 |

Dimensions in mm

MG = diaphragm size

**1) Connection type**

Code 55: Spigot BS 4825, Part 1

Code 59: Spigot ASME BPE/DIN EN 10357 series C (from 2022 issue)/DIN 11866 series C

Code 63: Spigot ANSI/ASME B36.19M schedule 10s

Code 64: Spigot ANSI/ASME B36.19M schedule 5s

Code 65: Spigot ANSI/ASME B36.19M schedule 40s

**2) Valve body material**

Code 40: 1.4435 (F316L), forged body

Code 42: 1.4435 (BN2), forged body, Δ Fe < 0.5%

Code F4: 1.4539 / UNS N08904, forged body

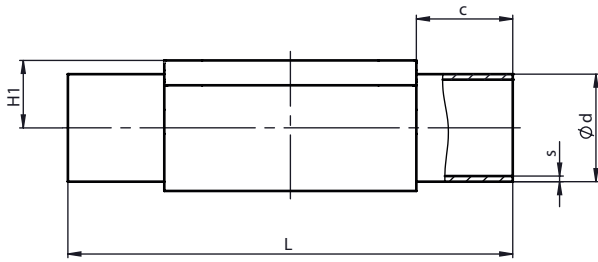

Connection type spigot ASME BPE (code 59)<sup>1)</sup>, investment casting material (code C3)<sup>2)</sup>

| MG | DN | NPS  | c (min) | ød    | H1   | L     | s    |
|----|----|------|---------|-------|------|-------|------|
| 8  | 8  | 1/4" | 20.0    | 6.35  | 8.5  | 72.0  | 0.89 |
|    | 10 | 3/8" | 20.0    | 9.53  | 8.5  | 72.0  | 0.89 |
|    | 15 | 1/2" | 20.0    | 12.70 | 8.5  | 72.0  | 1.65 |
| 10 | 20 | 3/4" | 25.0    | 19.05 | 12.5 | 108.0 | 1.65 |
| 25 | 20 | 3/4" | 25.0    | 19.05 | 16.0 | 120.0 | 1.65 |
|    | 25 | 1"   | 25.0    | 25.40 | 19.0 | 120.0 | 1.65 |

Dimensions in mm

MG = diaphragm size

1) **Connection type**

Code 59: Spigot ASME BPE/DIN EN 10357 series C (from 2022 issue)/DIN 11866 series C

2) **Valve body material**

Code C3: 1.4435, investment casting

**Spigot JIS/SMS (code 35, 36, 37)**

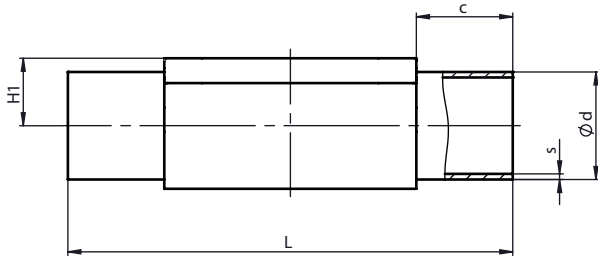

**Connection type spigot JIS/SMS (code 35, 36, 37)<sup>1)</sup>, forged material (code 40, 42, F4)<sup>2)</sup>**

| MG | DN | NPS  | c (min) | ød              |      |      | H1   | L     | s               |      |     |
|----|----|------|---------|-----------------|------|------|------|-------|-----------------|------|-----|
|    |    |      |         | Connection type |      |      |      |       | Connection type |      |     |
|    |    |      |         | 35              | 36   | 37   |      |       | 35              | 36   | 37  |
| 8  | 6  | -    | 20.0    | -               | 10.5 | -    | 8.5  | 72.0  | -               | 1.20 | -   |
|    | 8  | 1/4" | 20.0    | -               | 13.8 | -    | 8.5  | 72.0  | -               | 1.65 | -   |
| 10 | 10 | 3/8" | 25.0    | -               | 17.3 | -    | 12.5 | 108.0 | -               | 1.65 | -   |
|    | 15 | 1/2" | 25.0    | -               | 21.7 | -    | 12.5 | 108.0 | -               | 2.10 | -   |
| 25 | 15 | 1/2" | 25.0    | -               | 21.7 | -    | 19.0 | 120.0 | -               | 2.10 | -   |
|    | 20 | 3/4" | 25.0    | -               | 27.2 | -    | 19.0 | 120.0 | -               | 2.10 | -   |
|    | 25 | 1"   | 25.0    | 25.4            | 34.0 | 25.0 | 19.0 | 120.0 | 1.2             | 2.80 | 1.2 |

**Connection type spigot SMS (code 37)<sup>1)</sup>, investment casting material (code C3)<sup>2)</sup>**

| MG | DN | NPS | c (min) | ød   | H1   | L     | s   |
|----|----|-----|---------|------|------|-------|-----|
| 25 | 25 | 1"  | 25.0    | 25.0 | 19.0 | 120.0 | 1.2 |

Dimensions in mm

MG = diaphragm size

**1) Connection type**

Code 35: Spigot JIS-G 3447

Code 36: Spigot JIS-G 3459 schedule 10s

Code 37: Spigot SMS 3008

**2) Valve body material**

Code 40: 1.4435 (F316L), forged body

Code 42: 1.4435 (BN2), forged body, Δ Fe < 0.5%

Code C3: 1.4435, investment casting

Code F4: 1.4539 / UNS N08904, forged body

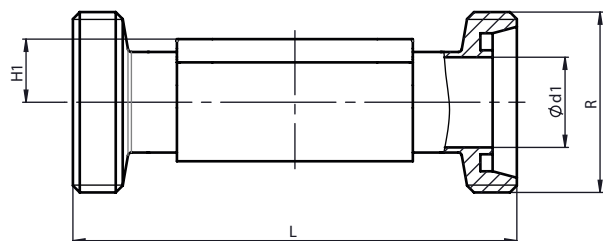
**Threaded spigot DIN (code 6)****Connection type threaded spigot DIN (code 6)<sup>1)</sup>, forged material (code 40, 42)<sup>2)</sup>**

| MG | DN | NPS  | Ød1  | H1   | L     | R           |
|----|----|------|------|------|-------|-------------|
| 8  | 10 | 3/8" | 10.0 | 8.5  | 92.0  | Rd 28 x 1/8 |
| 10 | 10 | 3/8" | 10.0 | 12.5 | 118.0 | Rd 28 x 1/8 |
|    | 15 | 1/2" | 16.0 | 12.5 | 118.0 | Rd 34 x 1/8 |
| 25 | 15 | 1/2" | 16.0 | 19.0 | 118.0 | Rd 34 x 1/8 |
|    | 20 | 3/4" | 20.0 | 19.0 | 118.0 | Rd 44 x 1/6 |
|    | 25 | 1"   | 26.0 | 19.0 | 128.0 | Rd 52 x 1/6 |

Dimensions in mm

MG = diaphragm size

**1) Connection type**

Code 6: Threaded spigot DIN 11851

**2) Valve body material**

Code 40: 1.4435 (F316L), forged body

Code 42: 1.4435 (BN2), forged body, Δ Fe &lt; 0.5%

**Cone spigot DIN (code 6K)**

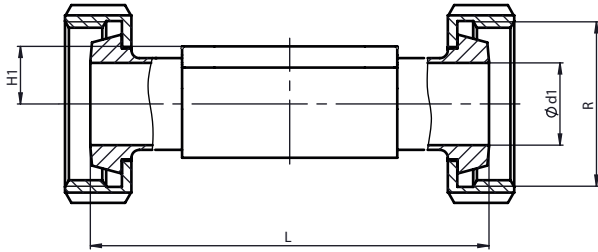

**Connection type cone spigot DIN (code 6K)<sup>1)</sup>, forged material (code 40, 42)<sup>2)</sup>**

| MG | DN | NPS  | Ød1  | H1   | L     | R           |
|----|----|------|------|------|-------|-------------|
| 8  | 10 | 3/8" | 10.0 | 8.5  | 90.0  | Rd 28 x 1/8 |
| 10 | 10 | 3/8" | 10.0 | 12.5 | 116.0 | Rd 28 x 1/8 |
|    | 15 | 1/2" | 16.0 | 12.5 | 116.0 | Rd 34 x 1/8 |
| 25 | 15 | 1/2" | 16.0 | 19.0 | 116.0 | Rd 34 x 1/8 |
|    | 20 | 3/4" | 20.0 | 19.0 | 114.0 | Rd 44 x 1/6 |
|    | 25 | 1"   | 26.0 | 19.0 | 127.0 | Rd 52 x 1/6 |

Dimensions in mm

MG = diaphragm size

**1) Connection type**

Code 6K: Cone spigot and union nut DIN 11851

**2) Valve body material**

Code 40: 1.4435 (F316L), forged body

Code 42: 1.4435 (BN2), forged body, Δ Fe < 0.5%

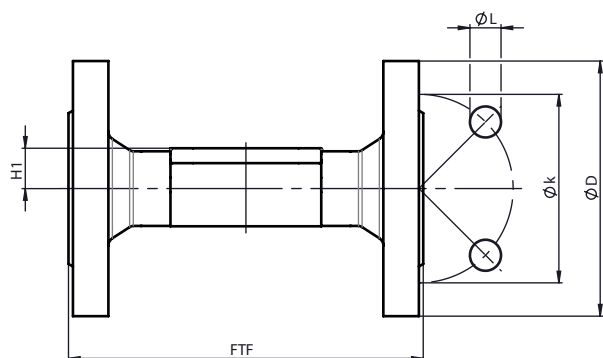
**Flange EN (code 8)****Connection type flange, length EN 558 (code 8)<sup>1)</sup>, investment casting material (code 39, C3), forged material (code 40, 42)<sup>2)</sup>**

| MG | DN | NPS  | øD    | FTF      |       |        | H1       |      |        | øk   | øL   | n |
|----|----|------|-------|----------|-------|--------|----------|------|--------|------|------|---|
|    |    |      |       | Material |       |        | Material |      |        |      |      |   |
|    |    |      |       | 39       | C3    | 40, 42 | 39       | C3   | 40, 42 |      |      |   |
| 25 | 15 | 1/2" | 95.0  | 130.0    | 150.0 | 150.0  | 18.0     | 13.0 | 19.0   | 65.0 | 14.0 | 4 |
|    | 20 | 3/4" | 105.0 | 150.0    | 150.0 | 150.0  | 20.5     | 16.0 | 19.0   | 75.0 | 14.0 | 4 |
|    | 25 | 1"   | 115.0 | 160.0    | 160.0 | 160.0  | 23.0     | 19.0 | 19.0   | 85.0 | 14.0 | 4 |

Dimensions in mm

MG = diaphragm size

n = number of bolts

**1) Connection type**

Code 8: Flange EN 1092, PN 16, form B, face-to-face dimension FTF EN 558 series 1, ISO 5752, basic series 1, length only for body configuration D

**2) Valve body material**

Code 39: 1.4408, PFA lined

Code 40: 1.4435 (F316L), forged body

Code 42: 1.4435 (BN2), forged body,  $\Delta Fe < 0.5\%$ 

Code C3: 1.4435, investment casting

**Flange ANSI Class (code 38, 39)**

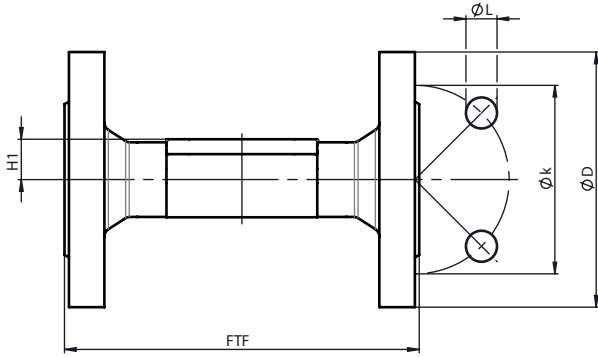

**Connection type flange, length MSS SP-88 (code 38)<sup>1)</sup>, investment casting material (code 39)<sup>2)</sup>**

| MG | DN | NPS  | øD    | FTF   | H1   | øk   | øL   | n |
|----|----|------|-------|-------|------|------|------|---|
| 25 | 20 | 3/4" | 100.0 | 146.0 | 20.5 | 69.9 | 15.9 | 4 |
|    | 25 | 1"   | 110.0 | 146.0 | 23.0 | 79.4 | 15.9 | 4 |

Dimensions in mm

MG = diaphragm size

n = number of bolts

**1) Connection type**

Code 38: Flange ANSI Class 150 RF, face-to-face dimension FTF MSS SP-88, length only for body configuration D

**2) Valve body material**

Code 39: 1.4408, PFA lined

**Connection type flange, length EN 558 (code 39)<sup>1)</sup>, investment casting material (code 39, C3), forged material (code 40, 42)<sup>2)</sup>**

| MG | DN | NPS  | øD    | FTF        |       | H1       |      |        | øk   | øL   | n |
|----|----|------|-------|------------|-------|----------|------|--------|------|------|---|
|    |    |      |       | Material   |       | Material |      |        |      |      |   |
|    |    |      |       | 39, 40, 42 | C3    | 39       | C3   | 40, 42 |      |      |   |
| 25 | 15 | 1/2" | 90.0  | 130.0      | 150.0 | -        | 13.0 | 19.0   | 60.3 | 15.9 | 4 |
|    | 20 | 3/4" | 100.0 | 150.0      | 150.0 | 20.5     | 16.0 | 19.0   | 69.9 | 15.9 | 4 |
|    | 25 | 1"   | 110.0 | 160.0      | 160.0 | 23.0     | 19.0 | 19.0   | 79.4 | 15.9 | 4 |

Dimensions in mm

MG = diaphragm size

n = number of bolts

**1) Connection type**

Code 39: Flange ANSI Class 125/150 RF, face-to-face dimension FTF EN 558 series 1, ISO 5752, basic series 1, length only for body configuration D

**2) Valve body material**

Code 39: 1.4408, PFA lined

Code 40: 1.4435 (F316L), forged body

Code 42: 1.4435 (BN2), forged body, Δ Fe < 0.5%

Code C3: 1.4435, investment casting

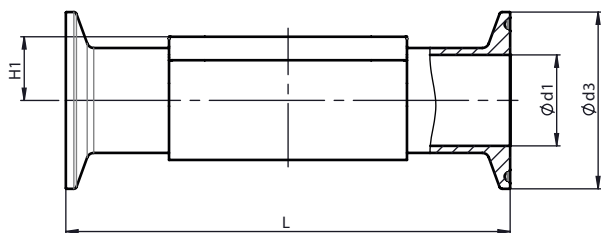
**Clamp DIN/ISO/ASME (code 80, 82, 88, 8A, 8E, 8P, 8T)****Connection type clamp DIN/ASME (code 80, 88, 8P, 8T)<sup>1)</sup>, forged material (code 40, 42, F4)<sup>2)</sup>**

| MG | DN | NPS  | ød1             |        | ød3             |        | H1   | L               |        |
|----|----|------|-----------------|--------|-----------------|--------|------|-----------------|--------|
|    |    |      | Connection type |        | Connection type |        |      | Connection type |        |
|    |    |      | 80, 8P          | 88, 8T | 80, 8P          | 88, 8T |      | 80, 8P          | 88, 8T |
| 8  | 8  | 1/4" | 4.57            | -      | 25.0            | -      | 8.5  | 63.5            | -      |
|    | 10 | 3/8" | 7.75            | -      | 25.0            | -      | 8.5  | 63.5            | -      |
|    | 15 | 1/2" | 9.40            | 9.40   | 25.0            | 25.0   | 8.5  | 63.5            | 108.0  |
| 10 | 15 | 1/2" | 9.40            | 9.40   | 25.0            | 25.0   | 12.5 | 88.9            | 108.0  |
|    | 20 | 3/4" | 15.75           | 15.75  | 25.0            | 25.0   | 12.5 | 101.6           | 117.0  |
| 25 | 20 | 3/4" | 15.75           | 15.75  | 25.0            | 25.0   | 19.0 | 101.6           | 117.0  |
|    | 25 | 1"   | 22.10           | 22.10  | 50.5            | 50.5   | 19.0 | 114.3           | 127.0  |

Dimensions in mm

MG = diaphragm size

**1) Connection type**

Code 80: Clamp ASME BPE, face-to-face dimension FTF ASME BPE, length only for body configuration D

Code 88: Clamp ASME BPE, for pipe ASME BPE, face-to-face dimension FTF EN 558 series 7, length only for body configuration D

Code 8P: Clamp DIN 32676 series C, face-to-face dimension FTF ASME BPE, length only for body configuration D

Code 8T: Clamp DIN 32676 series C, face-to-face dimension FTF EN 558 series 7, length only for body configuration D

**2) Valve body material**

Code 40: 1.4435 (F316L), forged body

Code 42: 1.4435 (BN2), forged body,  $\Delta Fe < 0.5\%$ 

Code F4: 1.4539 / UNS N08904, forged body

## Dimensions

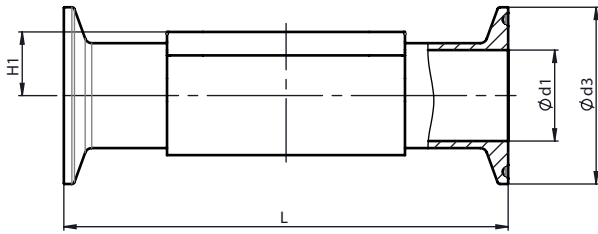

Connection type clamp DIN/ISO (code 82, 8A, 8E)<sup>1)</sup>, forged material (code 40, 42, F4)<sup>2)</sup>

| MG | DN | NPS  | ød1             |      |      | ød3             |      |      | H1   | L               |       |       |
|----|----|------|-----------------|------|------|-----------------|------|------|------|-----------------|-------|-------|
|    |    |      | Connection type |      |      | Connection type |      |      |      | Connection type |       |       |
|    |    |      | 82              | 8A   | 8E   | 82              | 8A   | 8E   |      | 82              | 8A    | 8E    |
| 8  | 6  | 1/8" | 7.0             | 6.0  | -    | 25.0            | 25.0 | -    | 8.5  | 63.5            | 63.5  | -     |
|    | 8  | 1/4" | 10.3            | 8.0  | -    | 25.0            | 25.0 | -    | 8.5  | 63.5            | 63.5  | -     |
|    | 10 | 3/8" | -               | 10.0 | -    | -               | 34.0 | -    | 8.5  | -               | 88.9  | -     |
| 10 | 10 | 3/8" | 14.0            | 10.0 | -    | 25.0            | 34.0 | -    | 12.5 | 108.0           | 108.0 | -     |
|    | 15 | 1/2" | 18.1            | 16.0 | -    | 50.5            | 34.0 | -    | 12.5 | 108.0           | 108.0 | -     |
| 25 | 15 | 1/2" | 18.1            | 16.0 | -    | 50.5            | 34.0 | -    | 19.0 | 108.0           | 108.0 | -     |
|    | 20 | 3/4" | 23.7            | 20.0 | -    | 50.5            | 34.0 | -    | 19.0 | 117.0           | 117.0 | -     |
|    | 25 | 1"   | 29.7            | 26.0 | 22.6 | 50.5            | 50.5 | 50.5 | 19.0 | 127.0           | 127.0 | 127.0 |

Dimensions in mm

MG = diaphragm size

### 1) Connection type

Code 82: Clamp DIN 32676 series B, face-to-face dimension FTF EN 558 series 7, length only for body configuration D

Code 8A: Clamp DIN 32676 series A, face-to-face dimension FTF acc. to EN 558 series 7, length only for body configuration D

Code 8E: Clamp ISO 2852 for pipe ISO 2037, clamps SMS 3017 for pipe SMS 3008, face-to-face dimension FTF EN 558 series 7, length only for body configuration D

### 2) Valve body material

Code 40: 1.4435 (F316L), forged body

Code 42: 1.4435 (BN2), forged body, Δ Fe < 0.5%

Code F4: 1.4539 / UNS N08904, forged body

## Body dimensions of tank bottom valve body and T body

Tank bottom valve body and T body: Dimensions and designs on request

## Accessories

### GEMÜ 1200

#### Proximity switch



The GEMÜ 1200 proximity switch is a sensor that detects the valve position contactlessly and displays it via an electrical signal.

For querying the closed position of the pneumatic actuator and the handwheel, a proximity switch each must be ordered separately.

Only use M8x1 proximity switches which can be mounted flush.

| Design  | Connection type | Order code             |
|---|-----------------|------------------------|
| 3-wire PNP, make contact,<br>IP67, 10–60 V DC, 100 mA | 2 m cable       | 1200M08Z1204002M0BJ079 |
|   | M12x1 plug      | 1200M08Z12060M124BJ077 |

Other proximity switches on request



GEMÜ Gebr. Müller Apparatebau GmbH & Co. KG  
Gert-Müller-Platz 1, 74635 Kupferzell, Germany  
Phone +49 (0) 7940 1230 · info@gemue.de  
www.gemu-group.com