

GEMÜ 628

2/2-way diaphragm valve



Features

- No auxiliary air pressure supply required
- Diaphragm valve body combinations for virtually all media available
- Optional flow direction
- Valve can be cleaned without disassembly of actuator
- Proven motorized actuators and control units in modular design

Description

The GEMÜ 628 motorized 2/2-way diaphragm valve has a motor/control units made by AUMA. The valve body has a weir-type design.

Technical specifications

- **Media temperature :** 0 to 150 °C
- **Ambient temperature:** 0 to 50 °C
- **Operating pressure :** 0 to 10 bar
- **Nominal sizes:** DN 32 to 150
- **Body configurations:** 2/2-way body
- **Connection types:** Flange | Threaded connection
- **Connection standards:** ANSI | BS | DIN | EN | NPT
- **Body materials:** EN-GJL-250, cast iron material | EN-GJS-400-18-LT, SG iron material | EN-GJS-400-18-LT, SG iron material with butyl lining | EN-GJS-400-18-LT, SG iron material with hard rubber lining | EN-GJS-400-18-LT, SG iron material with soft rubber lining | EN-GJS-400-18-LT, SG iron material, PFA lined | EN-GJS-400-18-LT, SG iron material, PP lined | EN-GJS-500-7, ductile iron material, PFA lined | EN-GJS-500-7, ductile iron material, PP lined
- **Diaphragm materials:** CR | EPDM | FKM | NBR | PTFE/EPDM
- **Conformities:** CRN | EAC

Technical data depends on the respective configuration



Product description

Construction

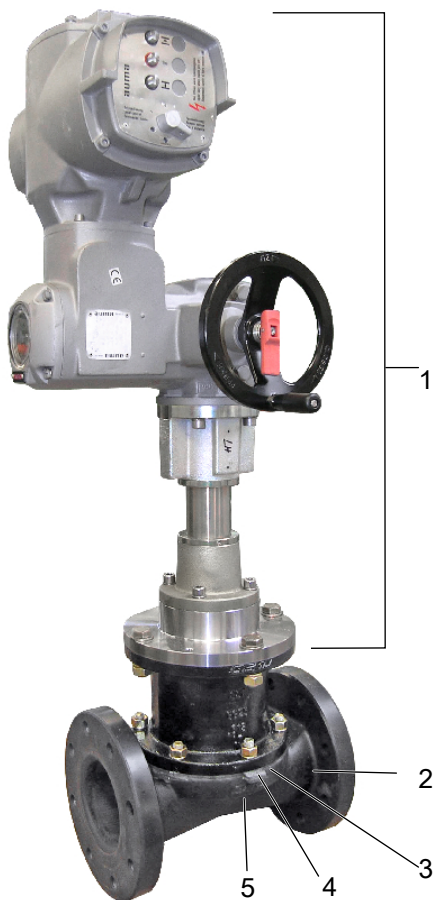

Item	Name	Materials
1	Motor and control units from the company AUMA	
2	Valve body	EN-GJL-250 (GG 25) EN-GJS-400-18-LT (GGG 40.3) EN-GJS-400-18-LT (GGG 40.3), butyl lined EN-GJS-400-18-LT (GGG 40.3), PFA lined EN-GJS-400-18-LT (GGG 40.3), PP lined EN-GJS-400-18-LT (GGG 40.3), hard rubber lined EN-GJS-400-18-LT (GGG 40.3), soft rubber lined EN-GJS-500-7 (GGG 50), PFA lined EN-GJS-500-7 (GGG 50), PP lined
3	Diaphragm	NBR CR EPDM FKM PTFE/EPDM (one-piece, two-piece)
4	CONEXO diaphragm RFID chip (see Conexo information)	
5	CONEXO body RFID chip (see Conexo information)	

GEMÜ CONEXO

The interaction of valve components that are equipped with RFID chips and an associated IT infrastructure actively increase process reliability.



Thanks to serialization, every valve and every relevant valve component such as the body, actuator or diaphragm, and even automation components, can be clearly traced and read using the CONEXO pen RFID reader. The CONEXO app, which can be installed on mobile devices, not only facilitates and improves the "installation qualification" process, but also makes the maintenance process much more transparent and easier to document. The app actively guides the maintenance technician through the maintenance schedule and directly provides him with all the information assigned to the valve, such as test reports, testing documentation and maintenance histories. The CONEXO portal acts as a central element, helping to collect, manage and process all data.

For further information on GEMÜ CONEXO please visit:

www.gemu-group.com/conexo

Ordering

GEMÜ Conexo must be ordered separately with the ordering option "CONEXO".

Availability

Availability of valve bodies

Threaded connection

MG	DN	Connection type code ¹⁾ 1, 31
		Material code ²⁾ 90
40	32	X
	40	X
50	50	X

MG = diaphragm size, X = standard

1) **Connection type**

Code 1: Threaded socket DIN ISO 228

Code 31: NPT female thread

2) **Valve body material**

Code 90: EN-GJS-400-18-LT (GGG 40.3)

Flange

MG	DN	Connection type code ¹⁾															
		8			38			39			51			53		56	
		Material code ²⁾															
		17, 82, 83, 88	18	90	17, 82, 83, 88	18 ³⁾	17, 82, 83, 88	18	90	17	81	91 ³⁾	8	17	17	81	91 ³⁾
40	32	X	X	X	-	-	X	X	X	-	-	-	-	-	-	-	-
	40	X	X	X	X	X	X	X	X	-	X	X	X	-	-	X	X
50	50	X	X	X	X	X	X	X	X	-	X	X	X	-	-	X	X
	65	X	X	X	X	X	X	X	X	-	-	-	-	-	-	-	-
65	65	-	-	-	-	-	-	-	-	-	-	-	X	-	-	-	-
80	80	X	X	X	X	X	X	X	X	-	X	X	X	-	-	X	X
100	100	X	X	X	X	X	X	X	X	-	X	X	X	-	-	X	X
	125	-	-	X	-	-	-	-	X	-	-	-	-	-	-	-	-
125	125	X	-	-	-	-	X	-	-	-	-	-	X	-	-	-	-
150	150	X	-	X	X	-	X	-	X	X	-	-	X	X	X	-	-

MG = diaphragm size, X = standard

1) **Connection type**

Code 8: Flange EN 1092, PN 16, form B, face-to-face dimension FTF EN 558 series 1, ISO 5752, basic series 1, length only for body configuration D

Code 38: Flange ANSI Class 150 RF, face-to-face dimension FTF MSS SP-88, length only for body configuration D

Code 39: Flange ANSI Class 125/150 RF, face-to-face dimension FTF EN 558 series 1, ISO 5752, basic series 1, length only for body configuration D

Code 51: Flange BS 10 table E, face-to-face dimension FTF EN 558 series 7, ISO 5752, basic series 7, length only for body configuration D

Code 53: Flange EN 1092, PN 16, form A, face-to-face dimension FTF EN 558 series 7, ISO 5752, basic series 7, length only for body configuration D

Code 56: Flange ANSI Class 125/150 RF, face-to-face dimension FTF EN 558 series 7, ISO 5752, basic series 7, length only for body configuration D

2) **Valve body material**

Code 8: EN-GJL-250 (GG 25)

Code 17: EN-GJS-400-18-LT (GGG 40.3), PFA lined

Code 18: EN-GJS-400-18-LT (GGG 40.3), PP lined

Code 81: EN-GJS-500-7 (GGG 50), PFA lined

Code 82: EN-GJS-400-18-LT (GGG 40.3), soft rubber lined

Code 83: EN-GJS-400-18-LT (GGG 40.3), hard rubber lined

Code 88: EN-GJS-400-18-LT (GGG 40.3), butyl lined

Code 90: EN-GJS-400-18-LT (GGG 40.3)

Code 91: EN-GJS-500-7 (GGG 50), PP lined

3) On request

Actuator assignment

MG	DN	Actuator	Control system
40	32 - 40	LE12.1 (50) + SA07.2 + AM01.1	LE12.1 (50) + SAR07.2 + AC01.2
50	50 - 65	LE12.1 (50) + SA07.2 + AM01.1	LE12.1 (50) + SAR07.2 + AC01.2
65	65	LE12.1 (50) + SA07.2 + AM01.1	LE12.1 (50) + SAR07.2 + AC01.2
80	80	LE25.1 (50) + SA07.6 + AM01.1	LE25.1 (50) + SAR07.6 + AC01.2
100	100 - 125	LE25.1 (50) + SA07.6 + AM01.1	LE25.1 (50) + SAR07.6 + AC01.2
125	125	LE25.1 (100) + SA07.6 + AM01.1	LE25.1 (100) + SAR07.6 + AC01.2
150	150	LE25.1 (100) + SA07.6 + AM01.1	LE25.1 (100) + SAR07.6 + AC01.2

MG = diaphragm size

LE 12.1 (50) = AUMA linear thrust unit with 50 mm stroke

LE 25.1 (100) = AUMA linear thrust unit with 100 mm stroke

Note:

As standard, the AUMA control AM01.1 is used for On/Off actuators and the AUMA control AC01.2 for control actuators. Other control units are available on request!

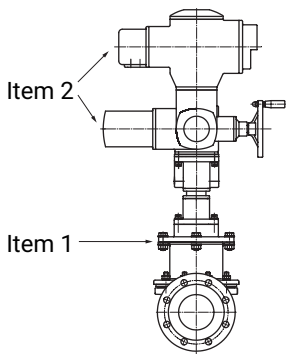

Note for order data The order must include 2 items!
Item 1: Valve with adapter and suitable AUMA linear thrust unit e.g. 628 80 D 53 13 14 For details of the AUMA linear thrust unit see AUMA's own technical documentation.
Item 2 AUMA rotary actuator* e.g. SA 07.2F1022D380/506822KN For details see AUMA's own technical documentation.
AUMA control unit* Standard type AM01.1TP110/001 1110KC3F18E1 For details see AUMA's own technical documentation

*Other types on request

Order data

The order data provide an overview of standard configurations.

Please check the availability before ordering. Other configurations available on request.

Products ordered with **bold marked ordering options** are so-called preferred series. Depending on the nominal size, these are available more quickly.

Order codes

1 Type	Code
Diaphragm valve with AUMA actuator	628

2 DN	Code
DN 32	32
DN 40	40
DN 50	50
DN 65	65
DN 80	80
DN 100	100
DN 125	125
DN 150	150

3 Body configuration	Code
2/2-way body	D

4 Connection type	Code
Threaded connection	
Threaded socket DIN ISO 228	1
NPT female thread	31
Flange	
Flange EN 1092, PN 16, form B, face-to-face dimension FTF EN 558 series 1, ISO 5752, basic series 1, length only for body configuration D	8
Flange ANSI Class 150 RF, face-to-face dimension FTF MSS SP-88, length only for body configuration D	38
Flange ANSI Class 125/150 RF, face-to-face dimension FTF EN 558 series 1, ISO 5752, basic series 1, length only for body configuration D	39
Flange BS 10 table E, face-to-face dimension FTF EN 558 series 7, ISO 5752, basic series 7, length only for body configuration D	51
Flange EN 1092, PN 16, form A, face-to-face dimension FTF EN 558 series 7, ISO 5752, basic series 7, length only for body configuration D	53
Flange ANSI Class 125/150 RF, face-to-face dimension FTF EN 558 series 7, ISO 5752, basic series 7, length only for body configuration D	56

5 Valve body material	Code
Cast iron material	
EN-GJL-250 (GG 25)	8

5 Valve body material	Code
SG iron material	
EN-GJS-400-18-LT (GGG 40.3), PFA lined	17
EN-GJS-400-18-LT (GGG 40.3), PP lined	18
EN-GJS-500-7 (GGG 50), PFA lined	81
EN-GJS-400-18-LT (GGG 40.3), soft rubber lined	82
EN-GJS-400-18-LT (GGG 40.3), hard rubber lined	83
EN-GJS-400-18-LT (GGG 40.3), butyl lined	88
EN-GJS-400-18-LT (GGG 40.3)	90
EN-GJS-500-7 (GGG 50), PP lined	91

6 Diaphragm material	Code
Elastomer	
NBR	2
FKM	4
CR	8
EPDM	29
PTFE	
PTFE/EPDM one-piece	54
PTFE/EPDM two-piece	5M

7 Actuator version	Code
Actuator version (see "Actuator assignment", page 6)	

8 CONEXO	Code
Without	
Integrated RFID chip for electronic identification and traceability	C

Order example

Ordering option	Code	Description
1 Type	628	Diaphragm valve with AUMA actuator
2 DN	50	DN 50
3 Body configuration	D	2/2-way body
4 Connection type	8	Flange EN 1092, PN 16, form B, face-to-face dimension FTF EN 558 series 1, ISO 5752, basic series 1, length only for body configuration D
5 Valve body material	17	EN-GJS-400-18-LT (GGG 40.3), PFA lined
6 Diaphragm material	5M	PTFE/EPDM two-piece
7 Actuator version		Actuator version (see "Actuator assignment", page 6)
8 CONEXO		Without

Technical data - Diaphragm valve

Medium

Working medium: Corrosive, inert, gaseous and liquid media which have no negative impact on the physical and chemical properties of the body and diaphragm material.

Temperature

Media temperature: 0 – 150 °C

Ambient temperature: 0 – 50 °C

Storage temperature: 0 – 40 °C

Pressure

Operating pressure:

MG	DN	Diaphragm material	
		EPDM/FKM	PTFE
40	32 - 40	0 - 10	0 - 6
50	50	0 - 10	0 - 6
65	65	0 - 10	0 - 6
80	80	0 - 8	0 - 5
100	100	0 - 6	0 - 4
125	125	0 - 6	0 - 4
150	150	0 - 6	0 - 4

MG = diaphragm size

Pressure values dependent on the material

All pressures are gauge pressures. Operating pressure values were determined with static operating pressure applied on one side of a closed valve. Sealing at the valve seat and atmospheric sealing is ensured for the given values.

Information on operating pressures applied on both sides and for high purity media on request.

Higher operating pressures on request

Pressure rating: PN 16

Leakage rate: Leakage rate A to P11/P12 EN 12266-1

Kv values:

MG	DN	Cast body without lining		Rubber lining	Plastic lining
		Threaded body	Flanged body		
		Material code 90		Material code 82, 83, 88	Material code 17, 18, 81, 91
40	32	28.0	36.0	29.0	23.0
	40	28.0	40.0	32.0	26.0
50	50	60.0	68.0	64.0	47.0
	65	-	68.0	64.0	47.0
65	65	-	100.0	-	-
80	80	-	130.0	128.0	110.0
100	100	-	200.0	190.0	177.0
	125	-	200.0	-	-
125	125	-	-	230.0	214.0
150	150	-	484.0	397.0	365.0

MG = diaphragm size

Kv values in m³/h

Kv values determined in accordance with DIN EN 60534, inlet pressure 5 bar, Δp 1 bar, with connection flange EN 1092 length EN 558 series 1 (or threaded socket DIN ISO 228 for body material GGG40.3) and soft elastomer diaphragm. The Kv values for other product configurations (e.g. other diaphragm or body materials) may differ. In general, all diaphragms are subject to the influences of pressure, temperature, the process and their tightening torques. Therefore the Kv values may exceed the tolerance limits of the standard.

The Kv value curve (Kv value dependent on valve stroke) can vary depending on the diaphragm material and term of use.

Product compliance

Machinery Directive: 2006/42/EC

Pressure Equipment Directive: 2014/68/EU

Mechanical data

Weight:

MG	DN	Weight
40	32 - 40	40.0
50	50	60.0
65	65	62.0
80	80	78.0
100	100	88.0
125	125	130.0
150	150	140.0

MG = diaphragm size
Weights in kg

Technical data of actuator

Note: For technical data see manufacturer's original datasheets

Dimensions

Actuator dimensions

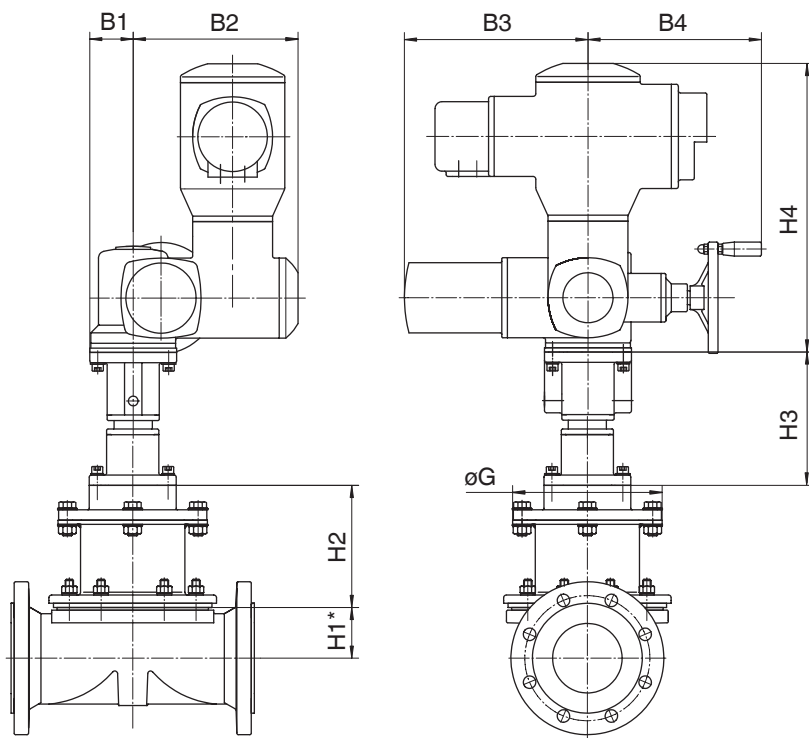

*For information regarding H1, see body dimensions

MG	DN	B1	B2	B3	B4	H2	H3	H4	øG
40	32 - 40	63.0	237.0	264.0	250.0	118.0	191.0	415.0	175.0
50	50 - 65	63.0	237.0	264.0	250.0	119.0	191.0	415.0	200.0
65	65	63.0	237.0	264.0	250.0	141.0	191.0	415.0	213.0
80	80	63.0	237.0	264.0	250.0	144.0	191.0	415.0	213.0
100	100 - 125	63.0	237.0	264.0	250.0	176.0	191.0	415.0	215.0
125	125	63.0	237.0	264.0	250.0	192.0	241.0	415.0	213.0
150	150	63.0	237.0	264.0	250.0	180.0	241.0	415.0	216.0

Dimensions in mm

Body dimensions

Flange EN (code 8)

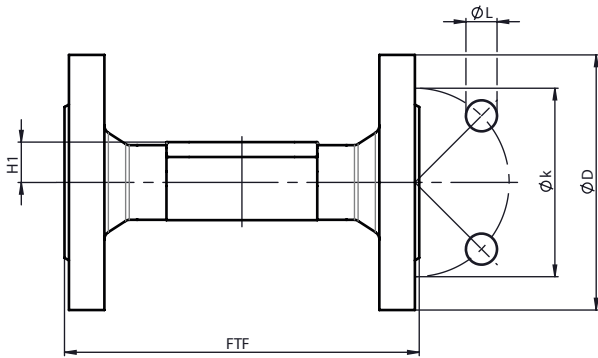

Connection type flange, length EN 558 (code 8)¹⁾, SG iron material (code 17, 18, 82, 83, 88, 90)²⁾

MG	DN	øD	øk	øL	n	H1			FTF		
						Material			Material		
						17, 82, 83, 88	18	90	17, 82, 83, 88	18	90
40	32	140.0	100.0	19.0	4	28.7	28.7	23.0	180.0	180.0	180.0
	40	150.0	110.0	19.0	4	33.0	33.0	27.0	200.0	200.0	200.0
50	50	165.0	125.0	19.0	4	39.0	39.0	32.0	230.0	230.0	230.0
	65	185.0	145.0	19.0	4	51.0	51.0	38.7	290.0	290.0	290.0
80	80	200.0	160.0	19.0	8	59.5	59.5	31.5	310.0	310.0	310.0
100	100	220.0	180.0	19.0	8	73.0	73.0	43.0	350.0	350.0	350.0
	125	250.0	210.0	19.0	8	-	-	58.0	-	350.0	400.0
125	125	250.0	210.0	19.0	8	87.0	-	-	400.0	-	-
150	150	285.0	240.0	23.0	8	109.0	-	58.0	480.0	-	480.0

Dimensions in mm

MG = diaphragm size

n = number of bolt holes

1) Connection type

Code 8: Flange EN 1092, PN 16, form B, face-to-face dimension FTF EN 558 series 1, ISO 5752, basic series 1, length only for body configuration D

2) Valve body material

Code 17: EN-GJS-400-18-LT (GGG 40.3), PFA lined

Code 18: EN-GJS-400-18-LT (GGG 40.3), PP lined

Code 82: EN-GJS-400-18-LT (GGG 40.3), soft rubber lined

Code 83: EN-GJS-400-18-LT (GGG 40.3), hard rubber lined

Code 88: EN-GJS-400-18-LT (GGG 40.3), butyl lined

Code 90: EN-GJS-400-18-LT (GGG 40.3)

Flange EN (code 53)

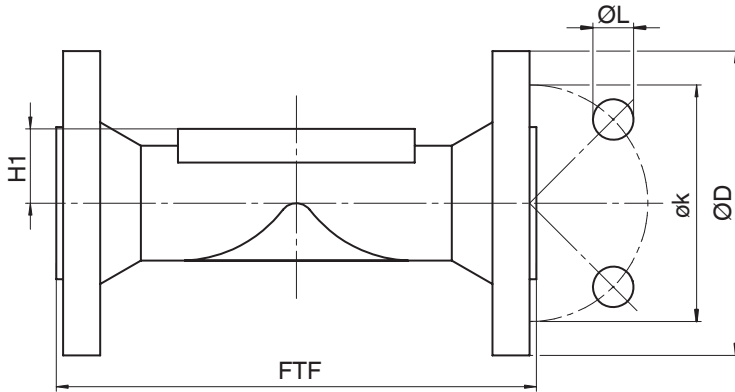

Connection type flange, length EN 558 (code 53)¹⁾, cast iron material (code 8), SG iron material (code 17)²⁾

MG	DN	øD		øk	øL	n	H1		FTF	
							Material		Material	
		8	17				8	17	8	17
40	32	140.0	-	100.0	19.0	4	28.0	-	-	-
	40	150.0	-	110.0	19.0	4	28.0	-	159.0	-
50	50	165.0	-	125.0	19.0	4	35.0	-	191.0	-
65	65	185.0	-	145.0	19.0	4	27.5	-	216.0	-
80	80	200.0	-	160.0	19.0	8	33.0	-	254.0	-
100	100	220.0	-	180.0	19.0	8	43.0	-	305.0	-
125	125	250.0	-	210.0	19.0	8	65.0	-	356.0	-
150	150	285.0	280.0 ³⁾	240.0	23.0	8	58.0	109.0	406.0	416.0

Dimensions in mm

MG = diaphragm size

n = number of bolt holes

1) **Connection type**

Code 53: Flange EN 1092, PN 16, form A, face-to-face dimension FTF EN 558 series 7, ISO 5752, basic series 7, length only for body configuration D

2) **Valve body material**

Code 8: EN-GJL-250 (GG 25)

Code 17: EN-GJS-400-18-LT (GGG 40.3), PFA lined

3) Diameter deviates from standard

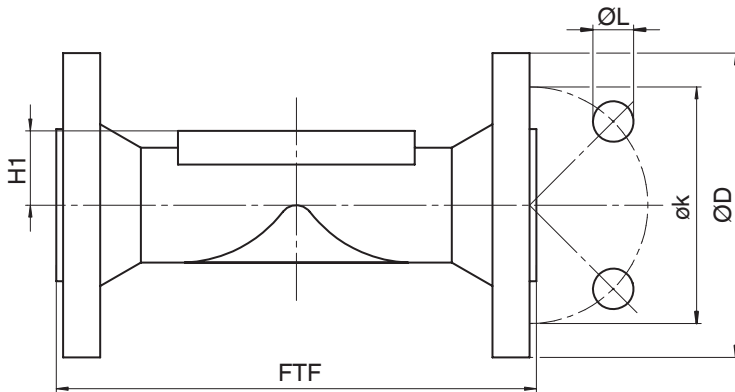
Flange ANSI Class (code 38, 39)**Connection type flange, length MSS SP-88 (code 38)¹⁾, SG iron material (code 17, 18, 82, 83, 88)²⁾**

MG	DN	øD	øk	øL	n	H1		FTF		
						Material		Material		
						17, 82, 83, 88	18	17	18	82, 83, 88
40	32	115.0	88.9	15.9	4	28.7	28.7	-	-	-
	40	125.0	98.4	15.9	4	33.0	33.0	175.0	175.0	171.4
50	50	150.0	120.7	19.0	4	39.0	39.0	200.0	200.0	197.4
	65	180.0	139.7	19.0	4	51.0	51.0	226.0	226.0	222.4
80	80	190.0	152.4	19.0	4	59.5	59.5	260.0	260.0	260.4
100	100	230.0	190.5	19.0	8	73.0	73.0	327.0	327.0	324.4
	125	255.0	215.9	22.2	8	-	-	-	-	-
125	125	255.0	215.9	22.2	8	87.0	-	-	-	-
150	150	280.0	241.3	22.2	8	109.0	-	416.0	-	416.0

Dimensions in mm, MG = diaphragm size

n = number of bolt holes

1) Connection type

Code 38: Flange ANSI Class 150 RF, face-to-face dimension FTF MSS SP-88, length only for body configuration D

2) Valve body material

Code 17: EN-GJS-400-18-LT (GGG 40.3), PFA lined

Code 18: EN-GJS-400-18-LT (GGG 40.3), PP lined

Code 82: EN-GJS-400-18-LT (GGG 40.3), soft rubber lined

Code 83: EN-GJS-400-18-LT (GGG 40.3), hard rubber lined

Code 88: EN-GJS-400-18-LT (GGG 40.3), butyl lined

Dimensions

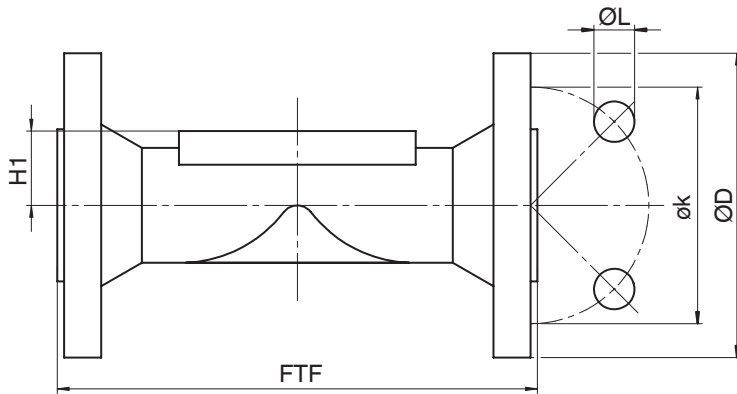

Connection type flange, length EN 558 (code 39), ¹⁾ SG iron material (code 17, 18, 82, 83, 88, 90) ²⁾

MG	DN	øD	øk	øL	n	H1			FTF		
						Material			Material		
						17, 82, 83, 88	18	90	17, 82, 83, 88	18	90
40	32	115.0	88.9	15.9	4	28.7	28.7	23.0	180.0	180.0	180.0
	40	125.0	98.4	15.9	4	33.0	33.0	27.0	200.0	200.0	200.0
50	50	150.0	120.7	19.0	4	39.0	39.0	32.0	230.0	230.0	230.0
	65	180.0	139.7	19.0	4	51.0	51.0	38.7	290.0	290.0	290.0
80	80	190.0	152.4	19.0	4	59.5	59.5	31.5	310.0	310.0	310.0
100	100	230.0	190.5	19.0	8	73.0	73.0	43.0	350.0	350.0	350.0
	125	255.0	215.9	22.2	8	-	-	58.0	-	-	400.0
125	125	255.0	215.9	22.2	8	87.0	-	-	400.0	-	-
150	150	280.0	241.3	22.2	8	109.0	-	58.0	480.0	-	480.0

Dimensions in mm, MG = diaphragm size

n = number of bolt holes

1) Connection type

Code 39: Flange ANSI Class 125/150 RF, face-to-face dimension FTF EN 558 series 1, ISO 5752, basic series 1, length only for body configuration D

2) Valve body material

Code 17: EN-GJS-400-18-LT (GGG 40.3), PFA lined

Code 18: EN-GJS-400-18-LT (GGG 40.3), PP lined

Code 82: EN-GJS-400-18-LT (GGG 40.3), soft rubber lined

Code 83: EN-GJS-400-18-LT (GGG 40.3), hard rubber lined

Code 88: EN-GJS-400-18-LT (GGG 40.3), butyl lined

Code 90: EN-GJS-400-18-LT (GGG 40.3)

Flange ANSI Class (code 56)

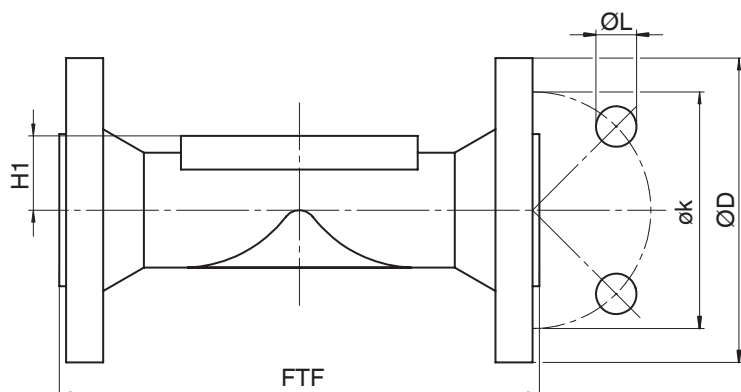

Connection type flange, length EN 558 (code 56), ¹⁾ SG iron material (code 17, 81, 91)²⁾

MG	DN	øD	øk	øL	n	H1		FTF	
						Material		Material	
						17	81, 91	17	81, 91
40	40	125.0	98.4	15.9	4	-	32.0	-	165.0
50	50	150.0	120.7	19.0	4	-	40.0	-	191.0
80	80	190.0	152.4	19.0	4	-	58.0	-	254.0
100	100	230.0	190.5	19.0	8	-	70.0	-	311.0
150	150	280.0	241.3	22.2	8	109.0	-	416.0	-

Dimensions in mm

MG = diaphragm size

n = number of bolt holes

1) **Connection type**

Code 56: Flange ANSI Class 125/150 RF, face-to-face dimension FTF EN 558 series 7, ISO 5752, basic series 7, length only for body configuration D

2) **Valve body material**

Code 17: EN-GJS-400-18-LT (GGG 40.3), PFA lined

Code 81: EN-GJS-500-7 (GGG 50), PFA lined

Code 91: EN-GJS-500-7 (GGG 50), PP lined

Flange BS (code 51)

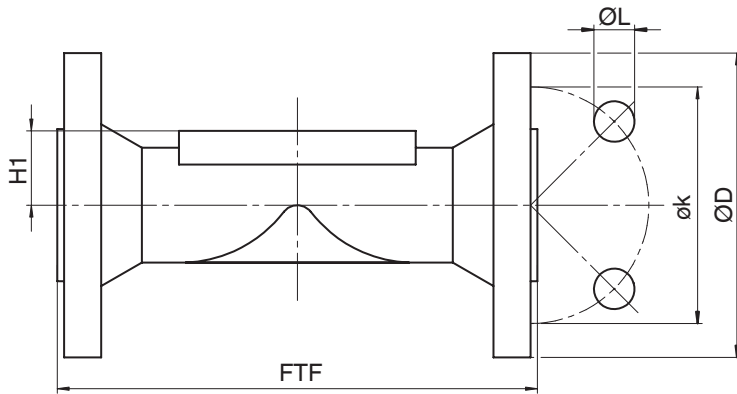

Connection type flange, length EN 558 (code 51), ¹⁾ SG iron material (code 17, 81, 91)²⁾

MG	DN	øD	øk	øL	n	H1		FTF	
						Materials		Materials	
						17	81, 91	17	81, 91
40	40	133.0	98.0	14.0	4	-	32.0	-	165.0
50	50	152.0	114.0	17.0	4	-	40.0	-	191.0
80	80	184.0	146.0	17.0	4	-	58.0	-	254.0
100	100	216.0	178.0	17.0	8	-	70.0	-	311.0
150	150	279.0	235.0	22.0	8	109.0	-	416.0	-

Dimensions in mm

MG = diaphragm size

n = number of bolt holes

1) **Connection type**

Code 51: Flange BS 10 table E, face-to-face dimension FTF EN 558 series 7, ISO 5752, basic series 7, length only for body configuration D

2) **Valve body material**

Code 17: EN-GJS-400-18-LT (GGG 40.3), PFA lined

Code 81: EN-GJS-500-7 (GGG 50), PFA lined

Code 91: EN-GJS-500-7 (GGG 50), PP lined

Threaded socket DIN (code 1)

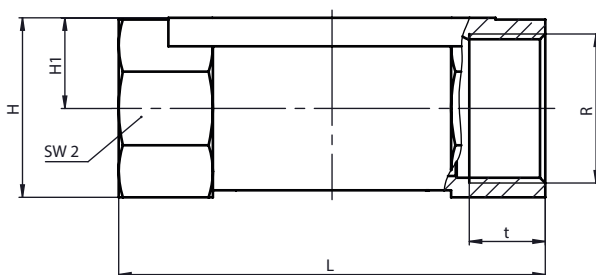

Connection type threaded socket (code 1)¹⁾, SG iron material (code 90)²⁾

MG	DN	NPS	H	H1	L	n	R	SW 2	t
40	32	1¼"	56.0	28.5	120.0	6	G 1¼	55	21.4
	40	1½"	66.0	33.5	140.0	6	G 1½	65	21.4

MG	DN	NPS	H	H1	L	n	R	SW 2	t
50	50	2"	76.0	38.5	165.0	6	G 2	75	25.7

Dimensions in mm

MG = diaphragm size

n = number of flats

1) **Connection type**

Code 1: Threaded socket DIN ISO 228

2) **Valve body material**

Code 90: EN-GJS-400-18-LT (GGG 40.3)

Threaded socket NPT (code 31)

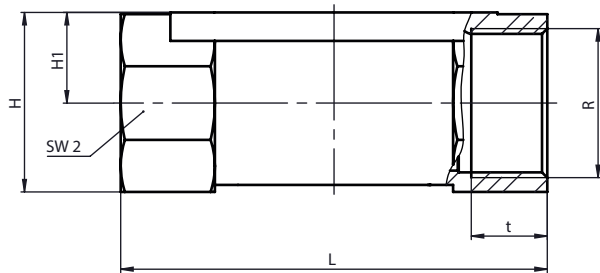

Connection type threaded socket NPT (code 31)¹⁾, SG iron material (code 90)²⁾

MG	DN	NPS	H	H1	L	n	R	SW 2	t
40	32	1¼"	56.0	28.5	120.0	6	NPT 1¼	55	17.3
	40	1½"	66.0	33.5	140.0	6	NPT 1½	65	17.3
50	50	2"	76.0	38.5	165.0	6	NPT 2	75	17.7

Dimensions in mm

MG = diaphragm size

n = number of flats

1) **Connection type**

Code 31: NPT female thread

2) **Valve body material**

Code 90: EN-GJS-400-18-LT (GGG 40.3)



GEMÜ Gebr. Müller Apparatebau GmbH & Co. KG
Fritz-Müller-Straße 6-8, 74653 Ingelfingen-Criesbach, Germany
Phone +49 (0) 7940 1230 · info@gemue.de
www.gemu-group.com