

GEMÜ 1441 cPos-X

Intelligent electro-pneumatic positioner



Features

- 2-wire-connection technology
- Quick commissioning using well-balanced preconfiguration
- HART communication available upon request
- Fail safe and Fail freeze safety function available
- BLE communication for remote access and configuration
- Almost no air consumption when idle

Description

The GEMÜ 1441 cPos-X is an intelligent, digital electro-pneumatic positioner in 2-wire technology used to control pneumatically operated process valves. It can be combined with single acting or double acting linear actuators or quarter turn actuators. This means that it can be used, among other things, for diaphragm, globe and diaphragm globe valves as well as for ball valves and butterfly valves, for instance. The positioner has a robust housing with a covered LCD display for status information. The positioner can be operated remotely using a mobile device in order to configure settings and to view detailed information.

Technical specifications

- **Ambient temperature:** -10 to 60 °C
- **Operating pressure :** 1.5 to 7 bar
- **Mode of action:** Double acting | Single acting
- **Flow rate:** 115 NI/min
- **Linear measuring range:** 2 to 75 mm
- **Radial measuring range:** 0 to 90°
- **Supply voltage:** Via set value signal
- **Electrical connection types:** M16 cable gland | M12 plug
- **Communication modes:** BLE | HART
- **Conformity:** ATEX | FCC | HART | IECEx | UL listed | UL Recognized

Technical data depends on the respective configuration



further information
webcode: GW-1441



Product line



	GEMÜ 1434 μPos	GEMÜ 1436 eco cPos	GEMÜ 1435 ePos	GEMÜ 1436 cPos	GEMÜ 1441 cPos-X
Controller type	Positioner	Positioner	Positioner	Positioners and process controllers	Positioner
Supply voltage	24 V DC	24 V DC	24 V DC	24 V DC	Via set value signal
Flow rate	15 NI/min	100 NI/min 84 NI/min	50 NI/min 90 NI/min	100 NI/min 172 NI/min 84 NI/min	115 NI/min
Ambient temperature	0 Up to 60 °C	0 Up to 60 °C	-20 Up to 60 °C	0 Up to 60 °C	-10 Up to 60 °C
Housing material	Housing cover: PP / housing base: Aluminium or stainless steel	Housing cover: PSU / housing base PP30	Aluminium	Housing cover: PSU / housing base PP30	Housing parts: PA/ inspection glass: PC
Control function of valve actuator					
Double acting	-	-	●	●	●
Single acting	●	●	●	●	●
Measuring range	Max. 30 mm, linear	Max. 30 mm, linear Max. 50 mm, linear Max. 75 mm, linear Max. 90°, radial	Max. 30 mm, linear Max. 50 mm, linear Max. 75 mm, linear Max. 90°, radial	Max. 30 mm, linear Max. 50 mm, linear Max. 75 mm, linear Max. 90°, radial	Max. 75 mm, linear Max. 90°, radial
Operating options	None	None	Keys on the product	Keys on the product	App via Bluetooth
Displays on the product	LEDs	LEDs	LCD display, with background light	LCD display, with background light	LCD display
Functions of the displays	Status display	Status display	Configuration Status display	Configuration Status display	Status display
Set value signal ¹⁾					
0–10 V	●	-	●	-	-
0–20 mA	●	-	●	●	-
4–20 mA	●	●	●	●	●
Analogue feedback signal					
0–10 V	●	-	●	-	-
0–20 mA	●	-	-	●	-
4–20 mA	●	●	●	●	●
Communication modes					
BLE	-	-	-	-	●
DeviceNet	-	-	-	●	-
HART	-	-	-	-	●
Profibus	-	-	-	●	-
ProfiNet	-	-	-	●	-
None	●	●	●	●	-
Digital inputs	-	-	-	●	●

					
	GEMÜ 1434 μPos	GEMÜ 1436 eco cPos	GEMÜ 1435 ePos	GEMÜ 1436 cPos	GEMÜ 1441 cPos-X
Digital outputs	-	-	●	●	●

1) Versions depending on the product, see order data

Product description

Construction



Item	Name	Materials
1	Housing cover	Grivory PA 6.6
2	Inspection glass	PC
3	Housing base	Grivory PA 6.6
4	Pneumatic panel	Grivory PA 6.6
C	Conexo	

GEMÜ CONEXO

The interaction of valve components that are equipped with RFID chips and an associated IT infrastructure actively increase process reliability.



Thanks to serialization, every valve and every relevant valve component such as the body, actuator or diaphragm, and even automation components, can be clearly traced and read using the CONEXO pen RFID reader. The CONEXO app, which can be installed on mobile devices, not only facilitates and improves the "installation qualification" process, but also makes the maintenance process much more transparent and easier to document. The app actively guides the maintenance technician through the maintenance schedule and directly provides him with all the information assigned to the valve, such as test reports, testing documentation and maintenance histories. The CONEXO portal acts as a central element, helping to collect, manage and process all data.

For further information on GEMÜ CONEXO please visit:

www.gemu-group.com/conexo

Ordering

GEMÜ Conexo must be ordered separately with the ordering option "CONEXO".

Order data

The order data provide an overview of standard configurations.

Please check the availability before ordering. Other configurations available on request.

Note: Pneumatic connecting components (union and compressed air tube) for the connection between the process valve and positioner are included with each positioner.

Note: A valve specific mounting kit is required for assembly. For designing the mounting kit, the valve type, nominal size, control function and actuator size must be stated.

Order codes

1 Type	Code
2-wire 1441 cPos-X	1441

2 Fieldbus	Code
Without	000
HART	HAR

3 Accessory	Code
Automation product	A

4 Action	Code
Single acting (fail-safe)	1
Double acting (fail-safe)	3
Single acting blocking (fail-freeze)	5
Double acting blocking (fail-freeze)	6

5 Device version	Code
Positioner	SA2

6 Signal type	Code
4–20 mA	A

7 Pneumatic connection	Code
G1/8 with 6 mm plug-in coupling	3
G1/8 with 1/4" plug-in coupling	U

8 Option	Code
Digital input and output	0
Analogue output, digital input and output	C

9 Electrical connection	Code
M12 plug	1
M16 x 1.5 cable gland	2

10 Flow rate	Code
115 NI/min	2

11 Travel sensor version	Code
Potentiometer, 75 mm length	075
Remote potentiometer, M12 connector	S01

12 Type of design	Code
Without	
Media wetted area cleaned to ensure suitability for paint applications, parts sealed in plastic bag	0101

12 Type of design	Code
Inversed direction, for quarter turn valves control function NO (2)	6960

13 Special version	Code
Without	
UL approval	U
ATEX (2014/34/EU), IECEx	X

14 CONEXO	Code
Integrated RFID chip for electronic identification and traceability	C

Order example

Ordering option	Code	Description
1 Type	1441	2-wire 1441 cPos-X
2 Fieldbus	000	Without
3 Accessory	A	Automation product
4 Action	1	Single acting (fail-safe)
5 Device version	SA2	Positioner
6 Signal type	A	4–20 mA
7 Pneumatic connection	3	G1/8 with 6 mm plug-in coupling
8 Option	0	Digital input and output
9 Electrical connection	1	M12 plug
10 Flow rate	2	115 NI/min
11 Travel sensor version	075	Potentiometer, 75 mm length
12 Type of design		Without
13 Special version		Without
14 CONEXO	C	Integrated RFID chip for electronic identification and traceability

Technical data

Medium

Working medium:	Compressed air and inert gases
Dust content:	Class 4, max. particle size 15 µm, max. particle density 5 mg/m ³
Pressure dew point:	Class 4 (10 K below the ambient temperature)
Oil content:	Class 4, max. oil concentration 25 mg/m ³ Quality classes to DIN ISO 8573-1

Temperature

Ambient temperature:	-10 – 60 °C
Storage temperature:	-10 – 60 °C

Pressure

Operating pressure:	1.5 – 7 bar Only the resistance to pressure was tested by UL. The applied pressure must not exceed the maximum control pressure of the process valve.
Flow rate:	115 NI/min (@ 25 °C; 6->5 bar)
Air consumption:	≤ 0.05 NI/min (when idle)

Product compliance

Machinery Directive:	Machinery Directive 2006/42/EC
Explosion protection:	ATEX (2014/34/EU) IECEX
ATEX marking:	Gas:  II 2G Ex ib IIB T4 Gb Certificate: IBExU23ATEX1002 X Notified body: IBExU, no. 0637
IECEX marking:	Gas:  Ex ib IIB T4 Gb Certificate: IECEX IBE 22.0016 X
RoHS Directive:	2011/65/EU
Radio Equipment Directive (RED):	2014/53/EU Technical standards used: Standard regarding the use of radio frequencies: EN 300 328 V2.2.2 (2019-07) Electromagnetic compatibility (EMC) for radio devices and services: EN 301 489-1 V2.2.3 (2019-11) EN 301 489-17 V3.2.4 (2020-09) Electrical safety: EN 61010-1:2010 + A1:2019 + A1:2019/AC:2019

FCC:

FCC §15.105 statement:

This equipment has been tested and found to comply with the limits for a Class A digital device, pursuant to part 15 of the FCC Rules. These limits are designed to provide reasonable protection against harmful interference in a residential installation. This equipment generates, uses and can radiate radio frequency energy and, if not installed and used in accordance with the instructions, may cause harmful interference to radio communications. However, there is no guarantee that interference will not occur in a particular installation. If this equipment does cause harmful interference to radio or television reception, which can be determined by turning the equipment off and on, the user is encouraged to try to correct the interference by one or more of the following measures:

- Reorient or relocate the receiving antenna.
- Increase the separation between the equipment and receiver.
- Connect the equipment into an outlet on a circuit different from that to which the receiver is connected.
- Consult the dealer or an experienced radio/TV technician for help.

FCC § 15.19 Labelling requirements:

This device complies with part 15 of the FCC Rules and ISSED license-exempt RSS standard(s).

Operation is subject to the following two conditions:

- (1) This device may not cause harmful interference, and
- (2) this device must accept any interference received, including interference that may cause undesired operation.

FCC § 15.21 Information to user:

Changes or modifications not expressly approved by the party responsible for compliance could void the user’s authority to operate the equipment.

RF Exposure Requirements:

This equipment complies with FCC and IC radiation exposure limits set forth for an uncontrolled environment. This equipment should be installed and operated with minimum distance of 20 cm between the radiator and your body. This transmitter must not be co-located or operating in conjunction with any other antenna or transmitter.

Contains FCC ID: QOQ-GM220P

UL approval:

UL approval (listed): UL 61010-1, CAN/CSA no. 61010-1-12

Mechanical data

Installation position:

Optional

Weight:

Approx. 970 g

Travel sensor:

Integrated for direct mounting, remote mounting possible

	Travel sensor version
Detection range:	0–75 mm
Operating range:	0–75 mm
Resistance:	5 kΩ
Minimum travel sensor change:	3% (only relevant for initialization)
Correlation - Travel sensor spindle/valve position	Retracted (top) ± 100% (valve open) Extended (bottom) ± 0% (valve closed)

Acoustic data

Noise emission:

> 85 dB (A)

Operating conditions

Ambient conditions:

Use in indoor spaces (only relevant for UL)

Ambient conditions:	Only use in dry environments (only relevant for UL)
Height:	Up to 2000 m (above sea level)
Relative air humidity:	Maximum 95%, non-condensing
Protection class:	IP 65 acc. to EN 60529 (not evaluated by UL) Type rating: 1
Degree of contamination:	3 (pollution degree)

Electrical data

Note regarding supply voltage in chapters 6.8.1 to 6.8.4 below (only relevant to UL):

- Class 2 power supply units in accordance with UL 1310.
- Safety extra-low voltage/limited power source.
- Safety extra-low voltage/limited energy circuits.

One of the three options listed above **must** be implemented by the customer.

Power supply / set value input

Supply power:	Via set value signal Note: The product is not intended to be supplied by a power source.
Power consumption:	< 0.3 W
Short-circuit proof:	Yes (up to max. 30 V DC) (not evaluated by UL)
Duty cycle:	Continuous duty
Electrical protection class:	III
Set value input:	4–20 mA
Input type:	passive
Load impedance:	typically 11.2 V DC (corresponds to 560 Ω at 20 mA) max. 12 V DC (corresponds to 600 Ω at 20 mA)
Accuracy/linearity:	≤ ±0.5% of full scale value
Temperature drift:	≤ ±0.1% of full scale value
Resolution:	12 bit
Reverse polarity protection:	Yes
Overload proof:	Yes (up to 30 V DC) (not evaluated by UL)

Analogue output (optional)

Accuracy:	≤ ±1% of full scale value
Signal:	4–20 mA
Supply voltage:	10 – 30 V DC 10 – 26.4 V DC (only relevant for UL)
Output type:	passive
Temperature drift:	≤ ±0.5% of full scale value
Resolution:	0.1 %
Short-circuit proof:	Yes (not evaluated by UL)
Overload proof:	Yes (up to 30 V DC) (not evaluated by UL)

Digital input

Function: Can be selected using software

Input type: passive

Input voltage: Typically 24 V DC (10 – 30 V DC)

Logic level "1": 10 – 30 V DC

Logic level "0": 0 – 4 V DC

Input current: Typically 6 mA DC

Digital output

Digital output:

	Version without ATEX	Version with ATEX (special version X)
Notes:	Maximum possible output current < 14 mA.	Digital output is configured as a NAMUR contact
Function:	Can be selected using software	
Supply voltage:	Typically 24 V DC (7 – 26.4 V DC)	8.2 V DC to NAMUR
Output type:	Passive Load: Resistive, general use (only relevant for UL)	
Logic level "1":	Conductive	Current consumption > 2.1 mA
Logic level "0":	Disabled	Current consumption < 1.2 mA

Travel sensor input (for travel length code S01 – remote potentiometer)

Note: Travel sensor input is not galvanically isolated from the supply voltage/set value input.

Input voltage range: 0 to U_{P+}

Supply voltage U_{P+} : Typically 0.48 V DC

Resistance range of remote potentiometers: 1.8 – 6 k Ω (ideal 5 k Ω \pm 20%)

Explosion protection

Intrinsically safe characteristic values

Input (energy supply with linear control characteristic):

Connection	Name	U_i	I_i	P_i	C_i	L_i
IW (XHART)	IW	30 V	65 mA		150 nF	100 μ H

Input (energy supply with rectangular control characteristic):

Connection	Name	U_i	I_i	P_i	C_i	L_i
IW (XHART)	IW	24 V	65 mA		150 nF	100 μ H

Passive outputs (energy supply with linear control characteristic):

Connection	Name	U_i	I_i	P_i	C_i	L_i
DigIn	DI	30 V	100 mA	1 W	250 nF	150 μ H
DigOut	DO	30 V	100 mA	1 W	250 nF	150 μ H
Iout	AO	30 V	90 mA	1 W	350 nF	150 μ H

Note: The input values are defined for the outputs (U_i , I_i , etc.). These outputs are passive (external power supply).

Active outputs (with linear control characteristic):

Connection	Name	U_o	I_o	P_o	C_o	L_o	Comment
UP	Travel sensor output	6 V	5 mA	30 mW	997 μ F	100 μ H	External resistive travel sensor

Intrinsically safe electric circuits

If a control without intrinsically safe outputs is used, the following safety barriers can be used in combination with GEMÜ 1441 cPos-X.

The safety certificates for the safety barriers mentioned can be downloaded from the GEMÜ website under product type 1441 in the product certificates section.

The safety barriers mentioned serve as a suggestion. Safety barriers from other manufacturers can also be used in accordance with the safety-relevant characteristic values.

Connection	Designation	Need	Controller order code	GEMÜ item number for safety barriers	Manufacturer	Manufacturer number
IW (XHART)	IW	Required	Standard	99183964	R. Stahl	9004/01-200-050-001
Iout	AO	Optional	Code C	99183970 99183967		9001/03-280-000-101 9001/01-280-085-101
DigIn	DI	Required**	Standard	99183967		9001/01-280-085-101
DigOut*	DO	Required**	Standard	99183967		9001/01-280-085-101
		Optional for current measurement		99183967		9001/01-280-085-101
				99183970		9001/03-280-000-101

* When using a digital output, it must be known on the control system side whether it is a NAMUR connection.

** If the DigIn or DigOut connection is not used, no safety barrier needs to be connected.

If wiring is to be implemented via remote IO, the following safety barriers can be used in combination with GEMÜ 1441 cPos-X.

Connection	Designation	GEMÜ item number for safety barriers	Manufacturer	Manufacturer number	Notes
IW (XHART)	IW	99183964	R. Stahl	9004/01-200-050-001	This combination only works with the remote I/O from R.Stahl 9469/35-08-12

Positioner data

Note: The following diagram is valid for valves with a standard assignment of the spindle position to the valve position (see "Mechanical data", page 8).

Control diagram: Default setting / The control characteristic is adjustable.

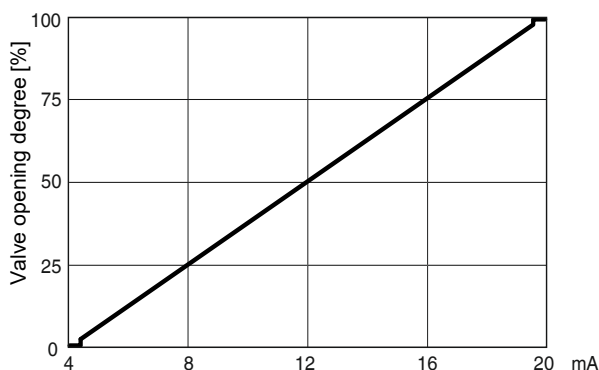

During initialization, the 1441 cPos-X positioner automatically detects the control function of the valve and is adjusted by default so that the valve is closed when the signal is 4 mA*.

The assignment can subsequently be changed using parameters. The close-tight function that is integrated as standard ensures that the valve is moved completely to the end position when the signal Open or Close valve is given.

* For double acting actuators, depends on the pneumatic actuator

Positioner information:

Control error:	1% default setting
(Dead zone)	0.1–25.0% (can be set at fixed values) 0.1–25.0% (adaptive self-adjustment)
Parameterization:	Via app or HART
Initialization:	Automatic via magnetic switch, app, digital input or HART
Close tight function:	Closed: $W \leq 0.5\%$ Open: $W \geq 99.5\%$ (can be changed via the app)

Interface:

	Bluetooth Low Energy	HART
Function	Parameterization, configuring, diagnostics	Parameterization, configuring, diagnostics
	Device status via app ¹⁾	Protocol Version 7 Device status via EDD
Prerequisite	Compatible smartphone/tablet with Android or iOS ¹⁾ <ul style="list-style-type: none"> • Apple iOS: Version 11 or higher • Android: Version 7.0 ("Nougat") or higher • Bluetooth 4.0 LE or newer 	-

¹⁾ The compatible GEMÜ app can be downloaded in the respective stores (Apple App Store or Google Play Store).

Dimensions

Wireless-specific parameters

Frequency: 2.4 GHz (2.4–2.4835 GHz)

Output power: Max. 11.2 dBm

Technology: Bluetooth Low Energy (only possible in conjunction with the GEMÜ app)

Dimensions

Positioner 1441

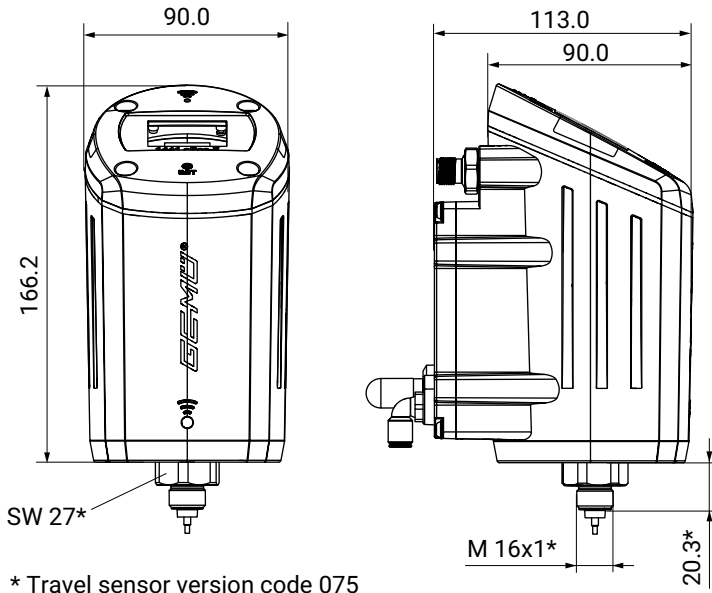

* Travel sensor version code 075

Dimensions in mm

1441 000 ZMP mounting bracket for remote mounting

Remote mounting (see page 21)

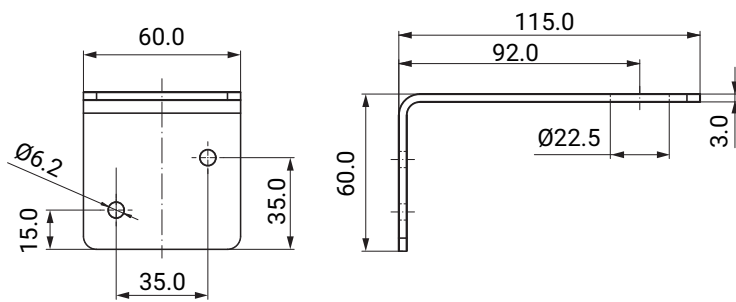

Dimensions in mm

1441 000 ZMB mounting bracket for remote mounting with the GEMÜ 4231 travel sensor for remote mounting

Remote mounting (see page 22)

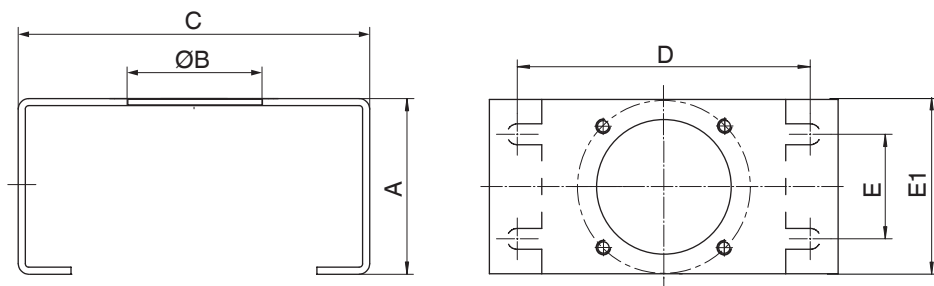

A	ØB	C	D	E	E1
45.0	36.0	100.0	84.0	50.0	30.0

Dimensions in mm

1441PTAZ mounting bracket for direct mounting on quarter turn actuators

Direct mounting (see page 22)

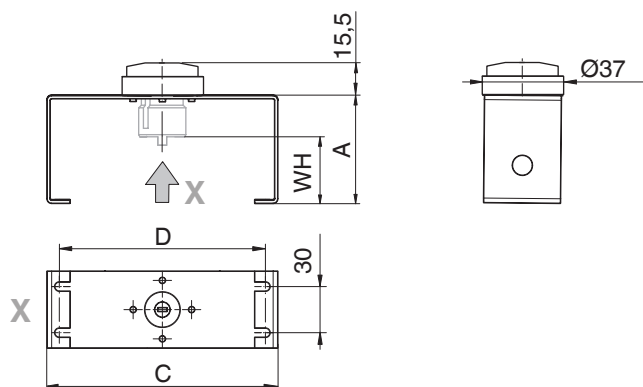

Shaft height WH	Hole spacing D	A	C
20.0	80.0	40.0	100.0
30.0	80.0	50.0	100.0
50.0	130.0	70.0	150.0

Dimensions in mm

Pneumatic connection

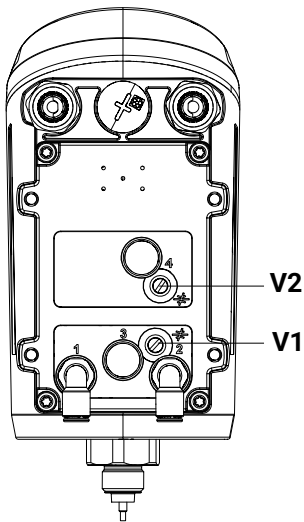

Connection in accordance with DIN ISO 1219-1	Designation	Size
1	Supply connection	G1/8 female thread ¹⁾
3	Venting (with silencer)	G1/8 female thread
V1	Supply and exhaust air throttle for A1	-
V2 ²⁾	Supply and exhaust air throttle for A2	-
2	Working connection (1) for process valve (control function NC and NO)	G1/8 female thread ¹⁾
4 ²⁾	Working connection (2) for process valve (control function DA)	G1/8 female thread ¹⁾

1) The connections that are to be used are equipped with push-in fittings at the factory (depending on the order code for pneumatic lines 6/4 mm or 1/4").

2) Only available for the double acting action (code 3 or 6).

Electrical connection

Electrical connection with M12

Only relevant for UL:

- All M12 connectors and cables must be designed for min. 60 V DC and 70 °C.
- All M12 connectors must comply with the standards UL2237 or UL2238 (PVVA/7, PVVA2/8, CYJV/7, CYJV2/8)
- The stranded wires used must have a cross-section of 0.14 mm² or AWG26.

Position of the connectors

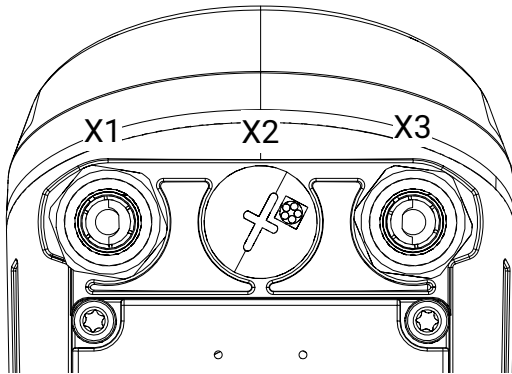

Connection X1

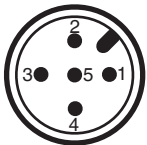

5-pin M12 plug, A-coded

Pin	Signal name
1	Iw+ set value input (4...20 mA current loop)/optionally HART
2	Iw- set value input (4...20 mA current loop)/optionally HART
3	n.c.
4	Iout+, actual value output (4...20 mA / no internal supply; passive) / optional
5	Iout-, actual value output (4...20 mA / no internal supply; passive) / optional

Connection X3



5-pin M12 plug, B-coded

Pin	Signal name
1	DigIn +
2	DigIn -
3	n.c.
4	DigOut+
5	DigOut-

Order option with external actual value potentiometer, code S01

Connection X2



Five-pin M12 built-in socket, A-coded

Pin	Signal name
1	UP+, output potentiometer supply voltage (+)
2	UP, input potentiometer wiper voltage
3	UP-, output potentiometer supply voltage (-)
4	n.c.
5	n.c.

Electrical connection with cable bushing

Note: On the version with an external actual value potentiometer (code S01), a connector is always attached at connection X2.

Connection X1/X3:

M16 cable gland

Recommended cable diameter:

EX-protected version (blue cable gland): 7–9 mm

Non-EX-protected version (black cable gland): 4–10 mm

Cross section of wire: 0.5–2.5 mm² / AWG 20 to 12

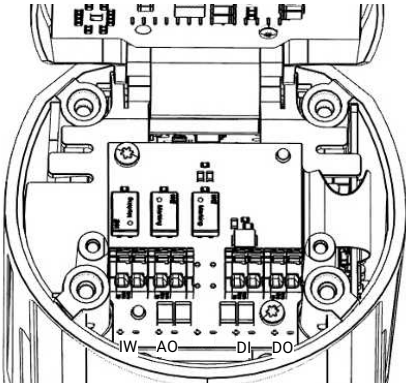

Terminal	Terminal label	Terminal name	Signal name
1	IW+	Iw+	Iw+, set value input (4–20 mA current loop)/opt. HART
2	IW-	Iw-	Iw-, set value input (4–20 mA current loop)/opt. HART
3	AO+	Iout+	Iout+, actual value output (4–20 mA/ no internal supply; passive)
4	AO-	Iout-	Iout-, actual value output (4–20 mA/ no internal supply; passive)
5	DI+	DigIn +	Digital input
6	DI-	DigIn	GND, digital input
7	DO+	DigOut+	Digital output
8	DO-	DigOut-	GND, digital output

Fail safe functions

Fail safe functions

Case	Error	Connection A1 (2)	Connection A2 (4)
1	Power supply failure	Single acting fail safe: Venting Single acting fail freeze: Blocking Double acting fail safe: Venting Double acting fail freeze: Blocking	Single acting: - (No connection available) Double acting fail safe: Venting Double acting fail freeze: Blocking
2	Compressed air supply failure	Single acting fail safe: Venting Single acting fail freeze: Blocking Double acting fail safe: Venting Double acting fail freeze: Blocking	Single acting: - (No connection available) Double acting fail safe: Venting Double acting fail freeze: Blocking
However, the fail safe function does not replace the plant-specific safety devices.			

Adjustable safety reactions

Error	Connection A1 (2)	Connection A2 (4)
Set value < 4 mA (range below the set value under I Min W can be adjusted 0–22 mA)	Single and double acting Adjustable function (Open, Close, Hold, Safe*)	Single acting: (Connection not available) Double acting: Adjustable function (Open, Close, Hold, Safe*)
Set value > 20 mA (range below the set value I max can be adjusted from 0–22 mA)	Single and double acting Adjustable function (Open, Close, Hold, Safe*)	Single acting: (Connection not available) Double acting: Adjustable function (Open, Close, Hold, Safe*)
* Safe = default setting. In this case, the valve actuator is moved to its safety position (undefined for double acting)		

Mounting options

Mounting the positioner to linear actuators

Direct mounting

For direct mounting of the positioner on a valve with linear actuator, you need the following components

- GEMÜ 1441 positioner in travel sensor version code 075
- GEMÜ 1441 S01 Z... valve specific mounting kit for mounting the positioner

(When ordering, specify the valve type with nominal size and control function)

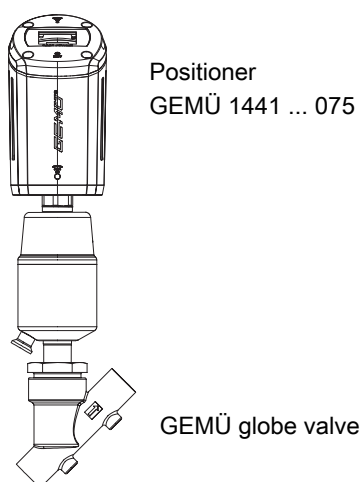

Remote mounting

For remote mounting of the positioner on a valve with linear actuator, you need the following components

- GEMÜ 1441 positioner in travel sensor version code S01 (remote potentiometer)
- GEMÜ 4232 ... 075... 4001 travel sensor

(Travel sensor version dependent on the valve used; cable length dependent on the required distance between the valve and positioner)

- GEMÜ 4232 S01 Z... valve-specific mounting kit for mounting the travel sensor
- GEMÜ 1441 000 ZMP mounting bracket (for wall mounting) or GEMÜ 1441 000 ZMB mounting bracket (for installation on level surfaces) (optional in each case) for securing the positioner

(When ordering, specify the valve type with nominal size and control function and the required distance to the mounting location of the positioner)

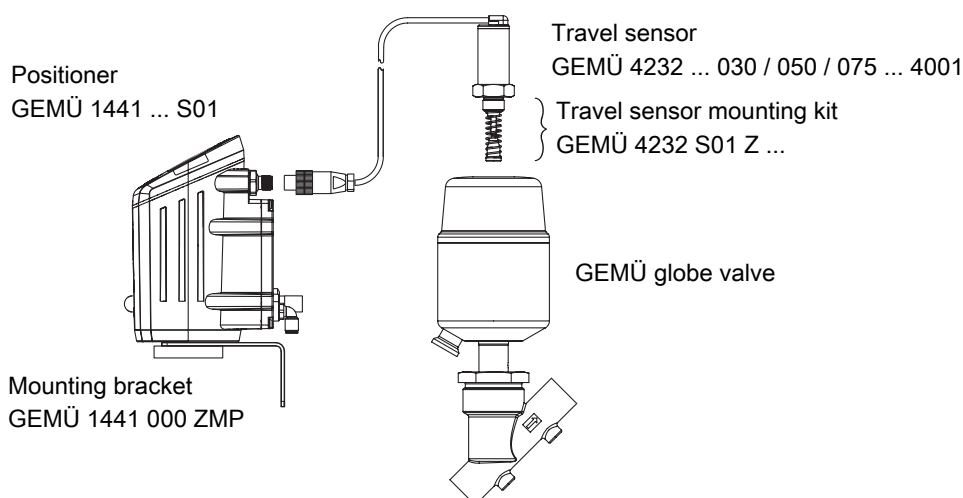

Mounting the positioner to quarter turn actuators

Direct mounting

For direct mounting of the positioner on a valve with quarter turn actuator, you need the following components

- GEMÜ 1441 ... 075 positioner
- GEMÜ 1441 PTAZXX 090 000 valve-specific mounting kit for mounting the positioner

(When ordering, specify the valve type with actuator flange size)

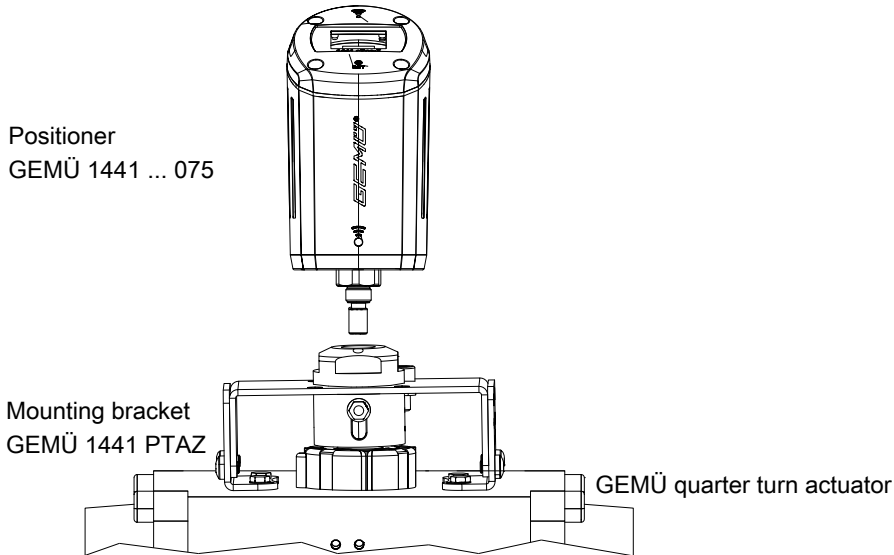

Remote mounting

For remote mounting of the positioner on a valve with quarter turn actuator, you need the following components

- GEMÜ 1441 positioner in travel sensor version code S01 (remote potentiometer)
- GEMÜ 4231...4001 travel sensor (cable length dependent on the required distance between the valve and positioner)
- 4231 PTAZ... ..090 000 valve-specific mounting kit for mounting the travel sensor
- GEMÜ 1441 000 ZMP mounting bracket (for wall mounting) or GEMÜ 1441 000 ZMB mounting bracket (for installation on level surfaces) (optional in each case) for securing the positioner

(When ordering, specify the actuator flange size and the required distance to the mounting location of the positioner)

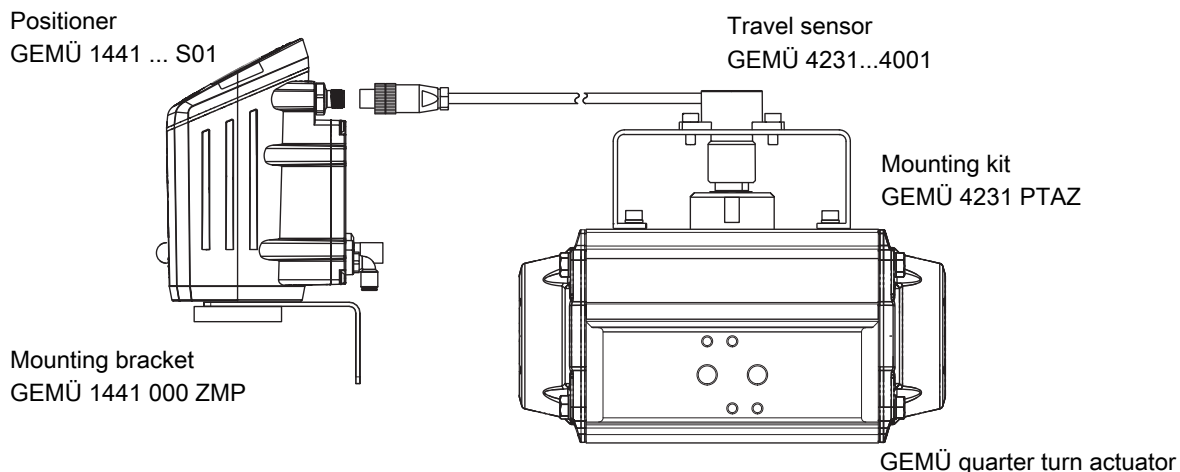

Accessories



GEMÜ 1441000ZMA

Programming magnet

The programming magnet is used to start automatic initialization.

Order designation	Designation	Order number
1441000ZMA	Programming magnet	88797237



GEMÜ 1441 S02 Z

Connection kit

The 1441 S02 Z ... connection kit is used to electrically connect the GEMÜ 1441 positioner to a control unit. The kit comprises pre-assembled cable connections with various connector plugs/sockets and suitable cables with selectable lengths or, alternatively, without a cable but with a threaded connection.

Order designation	Connection kit	Order number
1441S02Z00M0	X1/X3 angle, without cable	88789895
1441S02Z05M0	X1/X3 angle, 5m cable	88789896
1441S02Z10M0	X1/X3 angle, 10m cable	88789897

Other cable lengths or combinations on request.

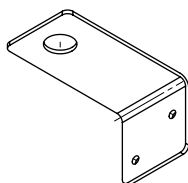

GEMÜ 1441 000 ZMP

Mounting bracket for external wall mounting

Mounting bracket for wall mounting

Order designation	Designation	Order number
1441000ZMP	Mounting bracket	88789568



GEMÜ 1441 000 ZMB

Mounting bracket

Order designation	Designation	Order number
1441000ZMB	Mounting bracket	88789569

Specific data for HART communication

Device identification

Manufacturer ID code: 0x6136

HART protocol revision: 7.8

Specific data for HART communication

Device ID code: 0xE4A5

Devices revision: 1

Number of device variables: 3

Supported physical layers: FSK

Physical devices category: Current input, actuator

Note on HART: The EDD file and an FDI package can be downloaded via <https://www.fieldcommgroup.org/registered-products> or www.gemugroup.com.

Dynamic variables

For positioners with HART communication, the variables PV, SV and TV are assigned as follows:

Variable	Device variable number	Name	Physical variable
HART primary variable (PV)	DV0	Set value	Set value (W) in %
HART secondary variable (SV)	DV1	Transformed set value	Transformed set value (PosW) in %
HART tertiary variable (SV)	DV2	Valve position	Actual value (X) in %

The flow chart below shows the internal device set value transformation:

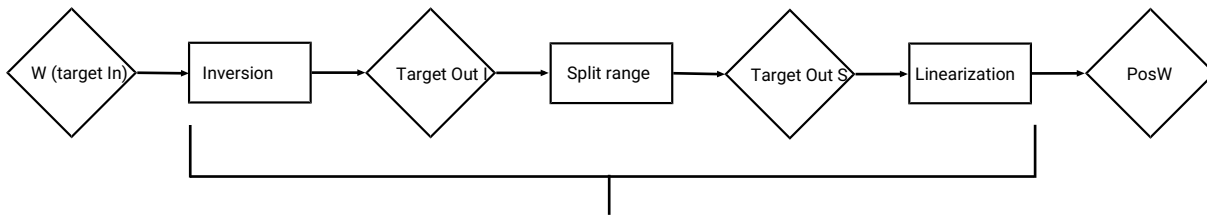

Internal device set value transformation (depending on parameter setting)



GEMÜ Gebr. Müller Apparatebau GmbH & Co. KG
Gert-Müller-Platz 1, 74635 Kupferzell, Germany
Phone +49 (0) 7940 1230 · info@gemue.de
www.gemu-group.com