

GEMÜ K410

Butterfly valve with bare shaft

EN **Operating instructions**



All rights including copyrights or industrial property rights are expressly reserved.

Keep the document for future reference.

© GEMÜ Gebr. Müller Apparatebau GmbH & Co. KG
25.03.2026

Contents

1	General information	4
1.1	Information	4
1.2	Symbols used	4
1.3	Definition of terms	4
1.4	Warning notes	4
2	Safety information	5
3	Product description	5
3.1	Configuration	5
3.2	Description	5
3.3	Product label	5
4	Intended use	6
5	Order data	7
6	Technical data	9
6.1	Medium	9
6.2	Temperature	9
6.3	Pressure	9
6.4	Product compliance	9
6.5	Mechanical data	10
7	Dimensions	11
7.1	Actuator flange F05/G05	11
7.2	Body	11
8	Manufacturer's information	12
8.1	Delivery	12
8.2	Transport	12
8.3	Storage	12
9	Installation in piping	12
9.1	Preparing for installation	12
9.2	Installation location	13
9.3	Mounting the product	13
10	Commissioning	13
11	Operation	13
12	Troubleshooting	13
13	Inspection and maintenance	14
13.1	Cleaning the product	14
13.2	Removing the butterfly valve from the piping	15
13.3	Replacing the shut-off seal	15
14	Spare parts	16
14.1	Ordering spare parts	16
14.2	Spare parts overview	16
15	Disposal	16
16	Returns	16
17	EU Declaration of Conformity	17

1 General information

1.1 Information

- The descriptions and instructions apply to the standard versions. For special versions not described in this document the basic information contained herein applies in combination with any additional special documentation.
- Correct installation, operation, maintenance and repair work ensure faultless operation of the product.
- Should there be any doubts or misunderstandings, the German version is the authoritative document.
- Contact us at the address on the last page for staff training information.

1.2 Symbols used

The following symbols are used in this document:

Symbol	Meaning
●	Tasks to be performed
▶	Response(s) to tasks
-	Lists

1.3 Definition of terms

Working medium

The medium that flows through the GEMÜ product.

Control medium

The medium whose increasing or decreasing pressure causes the GEMÜ product to be actuated and operated.

Control function

The possible actuation functions of the GEMÜ product.

1.4 Warning notes

Wherever possible, warning notes are organized according to the following scheme:

SIGNAL WORD	
Possible symbol for the specific danger	Type and source of the danger ▶ Possible consequences in case of non-compliance ● Measures for avoiding danger

Warning notes are always labelled with a signal word and sometimes also with a symbol for the specific danger.

The following signal words and danger levels are used:







⚠ DANGER	
	Imminent danger! ▶ Non-observance can cause death or severe injury

⚠ WARNING	
	Potentially dangerous situation! ▶ Non-observance can cause death or severe injury

⚠ CAUTION	
	Potentially dangerous situation! ▶ Non-observance can cause moderate to light injury

NOTICE	
	Potentially dangerous situation! ▶ Non-observance can cause damage to property

The following symbols for the specific dangers can be used within a warning note:

Symbol	Meaning
	Danger of explosion!
	The equipment is subject to pressure!
	Corrosive chemicals!
	Hot plant components!
	Maximum permissible pressure exceeded!
	Leakage!
	Risk of crushing!

2 Safety information

The safety information in this document refers only to an individual product. Potentially dangerous conditions can arise in combination with other plant components, which need to be considered on the basis of a risk analysis. The operator is responsible for the production of the risk analysis and for compliance with the resulting precautionary measures and regional safety regulations.

The document contains fundamental safety information that must be observed during commissioning, operation and maintenance. Non-compliance with these instructions may cause:

- Personal hazard due to electrical, mechanical and chemical effects
- Hazard to nearby equipment
- Failure of important functions
- Hazard to the environment due to the leakage of dangerous materials

The safety information does not take into account:

- Unexpected incidents and events, which may occur during installation, operation and maintenance
- Local safety regulations which must be adhered to by the operator and by any additional installation personnel

Prior to commissioning:

1. Transport and store the product correctly.
2. Do not paint the bolts and plastic parts of the product.
3. Carry out installation and commissioning using trained personnel.
4. Provide adequate training for installation and operating personnel.
5. Ensure that the contents of the document have been fully understood by the responsible personnel.
6. Define the areas of responsibility.
7. Observe the safety data sheets.
8. Observe the safety regulations for the media used.

During operation:

9. Keep this document available at the place of use.
10. Observe the safety information.
11. Operate the product in accordance with this document.
12. Operate the product in accordance with the specifications.
13. Maintain the product correctly.
14. Do not carry out any maintenance work and repairs not described in this document without consulting the manufacturer first.

In cases of uncertainty:

15. Consult the nearest GEMÜ sales office.

3 Product description

3.1 Configuration



Item	Name	Material
1	Valve body	PVC-U, grey
2	Pipe connections	PVC-U, grey

3.2 Description

GEMÜ K410 is a butterfly valve with bare shaft.

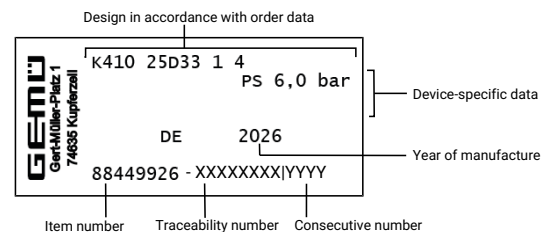

3.3 Product label



The month of manufacture is encoded in the traceability number and can be obtained from GEMÜ.

The product was manufactured in Germany.

4 Intended use

 DANGER	
	Danger of explosion! <ul style="list-style-type: none">▶ Risk of severe injury or death● Do not use the product in potentially explosive zones.● Only use the product in potentially explosive zones confirmed in the declaration of conformity.

 WARNING	
Improper use of the product! <ul style="list-style-type: none">▶ Risk of severe injury or death▶ Manufacturer liability and guarantee will be void.● Only use the product in accordance with the operating conditions specified in the contract documentation and in this document.	

The product is designed for installation in piping systems and for controlling a working medium.

- Use the product in accordance with the technical data.

5 Order data

The order data provide an overview of standard configurations.

Please check the availability before ordering. Other configurations available on request.

Products ordered with **bold marked ordering options** are so-called preferred series. Depending on the nominal size, these are available more quickly.

Order codes

1 Type	Code
Valve body, plastic	K410

2 DN	Code
DN 15	15
DN 20	20
DN 25	25
DN 32	32
DN 40	40
DN 50	50

3 Body configuration	Code
2/2-way body	D

4 Connection type	Code
Union end with insert (socket) – DIN	7
Union end with inch insert – BS (socket)	33

5 Body material	Code
PVC-U, grey	1

6 Shut-off seal material	Code
FKM	4
EPDM	14

Order example

Ordering option	Code	Description
1 Type	K410	Valve body, plastic
2 DN	25	DN 25
3 Body configuration	D	2/2-way body
4 Connection type	7	Union end with insert (socket) – DIN
5 Body material	1	PVC-U, grey
6 Shut-off seal material	14	EPDM

6 Technical data

6.1 Medium

Working medium: Corrosive, inert, gaseous and liquid media which have no negative impact on the physical and chemical properties of the body, disc and seal material. The product is only suitable for use with fluids of group 2 according to the Pressure Equipment Directive.

Control medium: Inert gases

6.2 Temperature

Media temperature: 0 – 60 °C

Ambient temperature: -10 – 60 °C

Storage temperature: 0 – 40 °C

Control medium temperature: max. 60 °C

6.3 Pressure

Operating pressure: 0 – 6 bar

Kv values:

DN	Kv value
15	7.0
20	13.0
25	17.0
32	33.0
40	53.0
50	74.0

Kv values in m³/h

Pressure/temperature correlation:

Material	Code	Temperature	Permissible operating pressure
PVC-U	1	10	10.0
		20	10.0
		25	10.0
		30	8.0
		40	6.0
		50	3.5
		60	1.5

Temperatures in °C

Pressures in bar

All pressures are gauge pressures.

The permissible operating pressure depends on the working medium temperature.

6.4 Product compliance

Pressure Equipment Directive: 2014/68/EU

6.5 Mechanical data**Torques:**

DN	Torques
15	6.0
20	6.0
25	6.0
32	8.0
40	20.0
50	21.0

Torques in Nm

Weight:

DN	Weights
15	0.360
20	0.390
25	0.400
32	0.700
40	1.072
50	1.200

Weights in kg

7 Dimensions

7.1 Actuator flange F05/G05

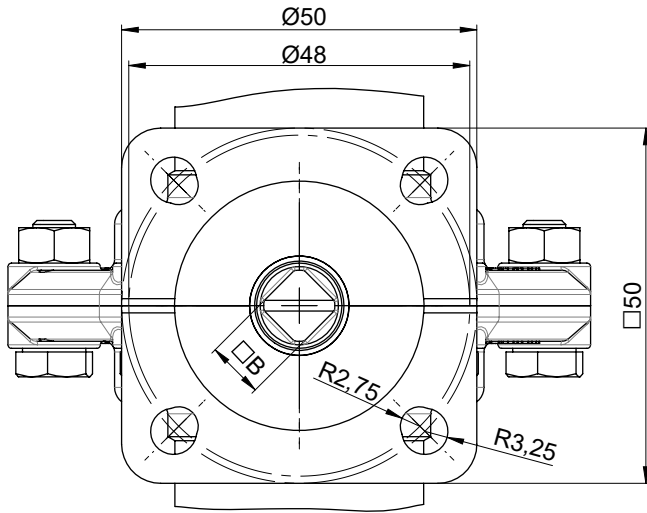

DN	□B	ØE	ØR	L max	L min	H2
15	8.0	25.0	10.0	18.0	7.0	13.0
20	8.0	25.0	10.0	18.0	7.0	13.0
25	8.0	25.0	10.0	18.0	7.0	13.0
32	8.0	65.0	10.0	34.0	22.0	13.0
40	8.0	80.0	12.0	42.0	30.0	13.0
50	8.0	90.0	12.0	42.0	30.0	13.0

Dimensions in mm

7.2 Body

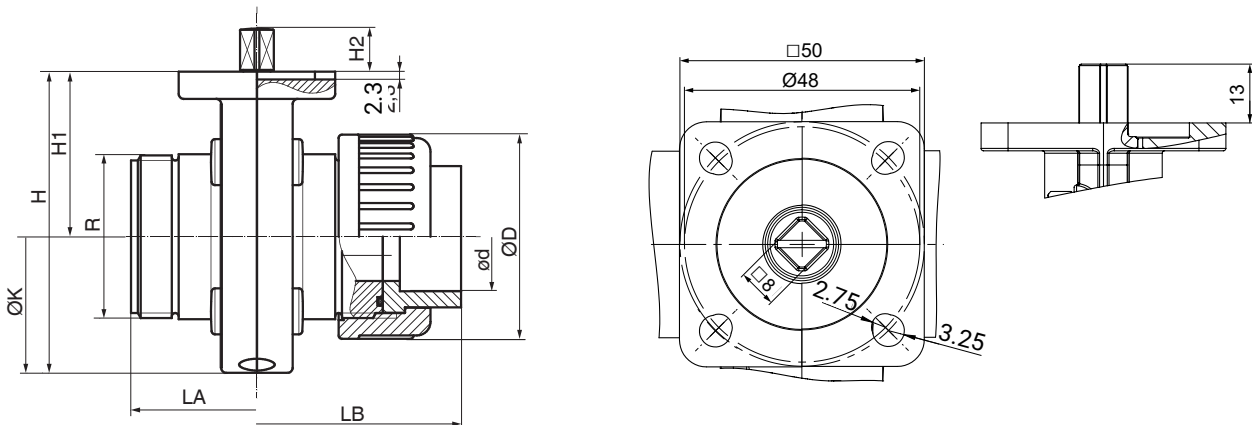

DN	LA	LB	H	H1	H2	øD	ød	R	øK
15	74.0	114.0	89.0	48.5	13.0	60.0	20.0	G 1 1/2	80.0
20	74.0	118.0	89.0	48.5	13.0	60.0	25.0	G 1 1/2	80.0
25	74.0	124.0	89.0	48.5	13.0	60.0	32.0	G 1 1/2	80.0
32	80.0	138.0	106.0	57.5	13.0	74.0	40.0	G 2	96.0
40	94.0	162.0	112.0	58.0	13.0	83.0	50.0	G 2 1/4	108.0
50	106.0	188.0	137.0	74.0	13.0	103.0	63.0	G 2 3/4	126.0

Dimensions in mm

8 Manufacturer's information

8.1 Delivery

- Check that all parts are present and check for any damage immediately upon receipt.

The product's performance is tested at the factory. The scope of delivery is apparent from the dispatch documents and the design from the order number.

8.2 Transport



1. Only transport the product by suitable means. Do not drop. Handle carefully.
2. After the installation dispose of transport packaging material according to relevant local or national disposal regulations / environmental protection laws.



8.3 Storage



1. Store the product free from dust and moisture in its original packaging.
2. Avoid UV rays and direct sunlight.
3. Do not exceed the maximum storage temperature (see chapter "Technical data").
4. Do not store solvents, chemicals, acids, fuels or similar fluids in the same room as GEMÜ products and their spare parts.
5. Close the compressed air connections with protection caps or sealing plugs.



9 Installation in piping

9.1 Preparing for installation

 WARNING	
	<p>The equipment is subject to pressure!</p> <ul style="list-style-type: none"> ▶ Risk of severe injury or death ● Depressurize the plant or plant component. ● Completely drain the plant or plant component.

 WARNING	
	<p>Corrosive chemicals!</p> <ul style="list-style-type: none"> ▶ Risk of caustic burns ● Wear appropriate protective gear. ● Completely drain the plant.

 CAUTION	
	<p>Hot plant components!</p> <ul style="list-style-type: none"> ▶ Burns ● Only work on plant that has cooled down. ● Wear protective gear.

 CAUTION	
	<p>Maximum permissible pressure exceeded!</p> <ul style="list-style-type: none"> ▶ Damage to the product! ● Provide for precautionary measures against exceeding the maximum permissible pressure that may be caused by pressure surges (water hammer).

 CAUTION	
Use as step!	
<ul style="list-style-type: none"> ▶ Damage to the product ▶ Risk of slipping-off ● Choose the installation location so that the product cannot be used as a foothold. ● Do not use the product as a step or a foothold. 	

NOTICE	
Suitability of the product!	
<ul style="list-style-type: none"> ▶ The product must be appropriate for the piping system operating conditions (medium, medium concentration, temperature and pressure) and the prevailing ambient conditions. 	

NOTICE	
Tools!	
<ul style="list-style-type: none"> ▶ The tools required for installation and assembly are not included in the scope of delivery. ● Use appropriate, functional and safe tools. 	

1. Ensure the product is suitable for the relevant application.
2. Check the technical data of the product and the materials.
3. Keep appropriate tools ready.
4. Wear appropriate protective gear, as specified in the plant operator's guidelines.
5. Observe appropriate regulations for connections.
6. Have installation work carried out by trained personnel.
7. Shut off plant or plant component.
8. Secure plant or plant component against recommissioning.
9. Depressurize the plant or plant component.
10. Completely drain the plant (or plant component) and let it cool down until the temperature is below the media vaporization temperature and cannot cause scalding.
11. Correctly decontaminate, rinse and ventilate the plant or plant component.
12. Lay piping so that the product is protected against transverse and bending forces, and also from vibrations and tension.
13. Only install the product between matching aligned pipes (see chapters below).
14. Please note the flow direction (see chapter "Flow direction").
15. Please note the installation position (see chapter "Installation position").

9.2 Installation location

1. Do not apply external force to the product
2. Choose the installation location so that the product cannot be used as a foothold.
3. Lay the piping so that the valve body is protected against thrust and bending forces, vibrations and tension.
4. Only install the product between matching aligned pipes.

Installation position

- Align the product preferably with the actuator facing upwards.
- Any direction of working medium is OK.

9.3 Mounting the product

1. Shut off the plant or plant component.
2. Secure against recommissioning.
3. Depressurize the plant or plant component.
4. Completely drain the plant or plant component and allow it to cool down until the temperature is below the media vaporization temperature and cannot cause scalding.
5. Correctly decontaminate, rinse and ventilate the plant or plant component.

⚠ CAUTION

Wrong solvent cement

- ▶ Valve body will be damaged.
- Only use solvent cement suitable for the valve body.



6. Screw the threaded connections into the piping in accordance with valid standards.
7. Unscrew the union nut 1 on the valve body 2.
8. Reinsert the O-ring if necessary.
9. Place the insert into the union nut 1.
10. Glue the union nut 1 with insert onto the pipe.
11. Reinsert the O-ring if necessary.
12. Screw the union nut 1 back onto the valve body.
13. Connect the valve body 2 on the other side to the pipe as well.

After the installation:

- Re-attach or reactivate all safety and protective devices.

10 Commissioning

⚠ WARNING



Corrosive chemicals!

- ▶ Risk of caustic burns
- Wear appropriate protective gear.
- Completely drain the plant.

⚠ CAUTION



Leakage!

- ▶ Emission of dangerous materials
- Provide for precautionary measures against exceeding the maximum permissible pressure that may be caused by pressure surges (water hammer).

⚠ CAUTION

Cleaning agent!

- ▶ Damage to the GEMÜ product
 - The plant operator is responsible for selecting the cleaning material and performing the procedure.
1. Check the tightness and the function of the product (close and reopen the product).
 2. Flush the piping system of new plant and following repair work (the product must be fully open).
 - ⇒ Harmful foreign matter has been removed.
 - ⇒ The product is ready for use.
 3. Commission the product.
 4. Commissioning of actuators in accordance with the enclosed instructions.

11 Operation

The product is operated via manual, pneumatic or motorized actuators.

12 Troubleshooting

Error	Possible cause	Troubleshooting
The product does not open/close or does not open/close fully	Foreign matter in the product	Remove and clean the product
The product does not close or does not close fully	Operating pressure too high	Operate the product with the operating pressure specified in the datasheet
	Shut-off seal incorrectly mounted or incorrect shut-off seal mounted	Replace or correctly mount the shut-off seal.
Product leaking between actuator and body	Shut-off seal faulty	Replace shut-off seal.
	Bolting loose	Tighten bolting.

Error	Possible cause	Troubleshooting
	Body faulty	Check body for potential damage, replace body if necessary.
Connection between body and piping leaking	Incorrect installation	Check installation of body in piping.
	O-ring missing or is contaminated or faulty	Replace O-ring.
	Union nut loose	Tighten the union nut.
Body leaking	Body faulty	Check body for potential damage, replace body if necessary.
	Shut-off seal faulty	Replace shut-off seal.
	Shut-off seal incorrectly mounted or incorrect shut-off seal mounted	Replace or correctly mount the shut-off seal.
	O-ring missing or is contaminated or faulty	Replace O-ring.

13 Inspection and maintenance

 **WARNING**



The equipment is subject to pressure!

- ▶ Risk of severe injury or death
- Depressurize the plant or plant component.
- Completely drain the plant or plant component.

 **CAUTION**



Hot plant components!

- ▶ Burns
- Only work on plant that has cooled down.
- Wear protective gear.

 **CAUTION**



Risk of crushing!

- ▶ There is a risk of crushing when reaching into the valve.
- Installation and removal of the valve may only be performed by suitable/trained personnel.
- Install only if the valve is deenergized (without control energy).
- When used as an end-of-line valve, a mating flange must be used.
- The operator must ensure that the valve is adequately secured by piping, e.g. pipe bends or grids.

NOTICE

Use of incorrect spare parts!

- ▶ Damage to the GEMÜ product
- ▶ The manufacturer liability and guarantee will be void.
- Use only genuine parts from GEMÜ.

NOTICE

Exceptional maintenance work!

- ▶ Damage to the GEMÜ product
- Any maintenance work and repairs not described in these operating instructions must not be performed without consulting the manufacturer first.

The operator must carry out regular visual examinations of the products, depending on the operating conditions and the potentially hazardous situations, in order to prevent leakage and damage.

1. Have servicing and maintenance work performed by trained personnel.
2. Wear appropriate protective gear as specified in the plant operator's guidelines.
3. Disconnect from power supply.
4. Shut off plant or plant component.
5. Secure plant or plant component against recommissioning.
6. Depressurize the plant or plant component.
7. Actuate products that are always in the same position four times a year.

13.1 Cleaning the product

- Clean the product with a damp cloth.
- Do **not** clean the product with a high pressure cleaning device.

13.2 Removing the butterfly valve from the piping

⚠ WARNING



The equipment is subject to pressure!

- ▶ Risk of severe injury or death
- Depressurize the plant or plant component.
- Completely drain the plant or plant component.

⚠ WARNING



Corrosive chemicals!

- ▶ Risk of caustic burns
- Wear appropriate protective gear.
- Completely drain the plant.

⚠ CAUTION



Hot plant components!

- ▶ Burns
- Only work on plant that has cooled down.
- Wear protective gear.

1. Maintenance work must only be performed by trained personnel.
2. Use appropriate protective gear as specified in plant operator's guidelines.
3. Move the butterfly valve to a slightly open position. The disc must not project from the body.
4. Loosen and remove flange bolts and nuts.
5. Spread the piping flanges.
6. Remove the butterfly valve.

13.3 Replacing the shut-off seal

Tools required:

- Hexagon wrench WAF 5
- Open-end wrench WAF 8
- Bearing grease (Molycote DC 111)

Removing the shut-off seal

- ✓ The actuator is removed.

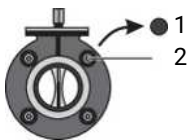

1. Remove the protective caps 1.
2. Undo the hexagon socket screws 2.
3. Keep the hexagon nuts in a safe place.
4. Press the two valve halves apart.

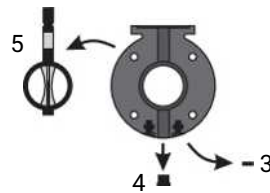

5. Keep the two square nuts 3 and protective cap 4 in a safe place.
6. Remove the disc 5 with shut-off seal.

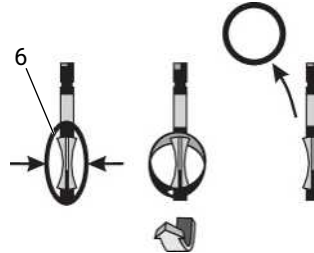

7. Squeeze the shut-off seal 6 and pull it down over the short part of the shaft towards the front.
8. Pull off the shut-off seal upwards over the long part of the shaft.

Mounting the shut-off seal

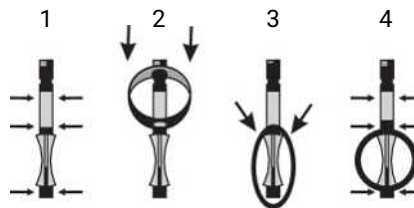

1. Lubricate the shaft of the butterfly disc above and below the disc (1).
2. Lubricate the shut-off seal in the axis/shaft area.
3. Push on the new shut-off seal with a hole over the long part of the shaft (2).
4. Squeeze the shut-off seal and slip it over the short part of the shaft (3).
5. Click the shut-off seal into position.
6. Lubricate the disc shaft above and below the shut-off seal (4).
7. Press the two valve halves apart.
8. Position the disc with shut-off seal between the two valve halves.
9. Push the two valve halves together.
10. Mount two square nuts and the protective cap.
11. Insert the hexagon socket screws and tighten with hexagon nuts diagonally until they are hand tight.
12. Press the protective caps into the valve body.

14 Spare parts

14.1 Ordering spare parts

NOTICE

Use of incorrect spare parts!

- ▶ Damage to the GEMÜ product
- ▶ The manufacturer liability and guarantee will be void.
- Use only genuine parts from GEMÜ.

When ordering spare parts, please provide the following information:

1. Complete order code
2. Item number
3. Traceability number
4. Name of spare part
5. Area of use (medium, temperatures and pressures)

14.2 Spare parts overview

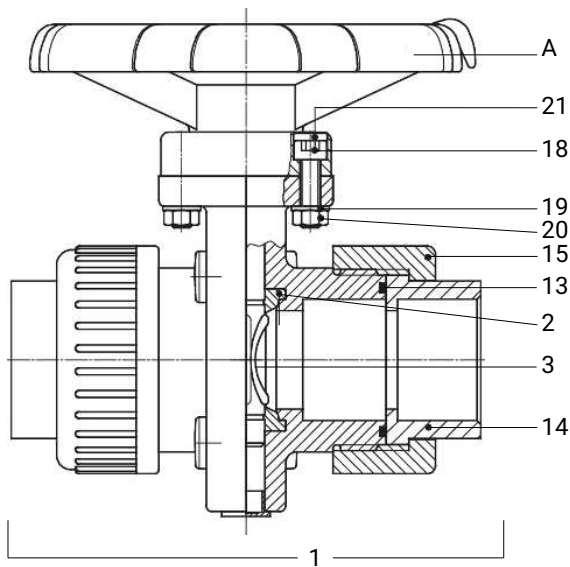

Item	Name	Order designation
1	Butterfly valve body, complete	K410
2	Shut-off seal	410 SLN
3	Butterfly disc, PP	410 SDS
13	O-ring	410 SOR
14	Insert	410 SCK
15	Union nut	410 SCK
18	Bolt	410 SVK
19	Washer	410 SVK
20	Nut	410 SVK
21	Protective cap	410 SVK
A	Actuator	9411

15 Disposal

1. Pay attention to adhered residual material and gas diffusion from penetrated media.
2. Dispose of all parts in accordance with the disposal regulations/environmental protection laws.

16 Returns

Legal regulations for the protection of the environment and personnel require that the completed and signed return delivery note is included with the dispatch documents. Returned goods can be processed only when this note is completed. If no return delivery note is included with the product, GEMÜ cannot process credits or repair work but will dispose of the goods at the operator's expense.

1. Clean the product.
2. Request a return delivery note from GEMÜ.
3. Complete the return delivery note.
4. Send the product with a completed return delivery note to GEMÜ.

17 EU Declaration of Conformity



Version 1.0

GEMÜ**EU-Konformitätserklärung**
EU Declaration of Conformity

Wir, die Firma

We, the company

GEMÜ Gebr. Müller Apparatebau GmbH & Co. KG
Gert-Müller-Platz 1
74635 Kupferzell
Deutschland

erklären hiermit in alleiniger Verantwortung, dass die nachfolgend bezeichneten Produkte den Vorschriften der genannten Richtlinien entspricht.

hereby declare under our sole responsibility that the below-mentioned products complies with the regulations of the mentioned Directives.

Produkt: GEMÜ K410**Product:** GEMÜ K410**Produktname:** Absperrklappe mit freiem Wellenende**Product name:** Butterfly valve with bare shaft**Richtlinien/Verordnungen:****Directives/Regulations:**PED 2014/68/EU¹⁾**Folgende harmonisierte Normen (oder Teile hieraus) wurden angewandt:****The following harmonized standards (or parts thereof) have been applied:**

EN ISO 16136:2006/A1:2019

¹⁾ PED 2014/68/EU**Einteilung gemäß Druckgeräterichtlinie 2014/68/EU, Artikel 4 und Anhang II:**
Fluidklasse 1 (gasförmig oder flüssig),
Diagramm 6, Kategorie I
Instabile Gase sind ausgeschlossen.**Notifizierte Stelle:**TÜV Rheinland Industrie Service GmbH
Am Grauen Stein 1
51105 Köln**Kennnummer der notifizierten Stelle:** 0035**Nr. des QS-Zertifikats:** 01 202 926/Q-02 0036**Angewandte(s) Konformitätsbewertungsverfahren:** Modul H**Hinweis für Produkte mit einer Nennweite ≤ DN 25:**

Die Produkte werden entwickelt und produziert nach GEMÜ eigenen Verfahrensweisungen und Qualitätsstandards, welche die Forderungen der ISO 9001 und der ISO 14001 erfüllen. Die Produkte dürfen gemäß Artikel 4, Absatz 3 der Druckgeräterichtlinie 2014/68/EU keine CE-Kennzeichnung tragen.

¹⁾ PED 2014/68/EU**Classification in accordance with the Pressure Equipment Directive 2014/68/EU, Article 4 and Annex II:**Fluid class 1 (gaseous or liquid),
Diagram 6, Category I
Unstable gases are excluded.**Notified body:**TÜV Rheinland Industrie Service GmbH
Am Grauen Stein 1
51105 Cologne**Identification number of the notified body:** 0035**QA certificate number:** 01 202 926/Q-02 0036**Applied conformity assessment procedures:** Module H**Note for products with a nominal size ≤ DN 25:**

The products are developed and manufactured in accordance with GEMÜ's own process instructions and quality standards, which meet the requirements of ISO 9001 and ISO 14001. In accordance with Article 4, Paragraph 3 of the Pressure Equipment Directive 2014/68/EU, the products are not permitted to bear the CE mark.

i.v. M. Barghoorn
Leiter Globale Technik
Kupferzell, 18.03.2026GEMÜ Gebr. Müller Apparatebau GmbH & Co. KG
Gert-Müller-Platz 1, 74635 Kupferzell, Deutschlandwww.gemu-group.com
info@gemu.de



GEMÜ Gebr. Müller Apparatebau GmbH & Co. KG
Gert-Müller-Platz 1, 74635 Kupferzell, Germany
Phone +49 (0) 7940 1230 · info@gemue.de
www.gemu-group.com

Subject to alteration

03.2026 | 88928553