

GEMÜ 650TL

Manually operated diaphragm valve

EN

Operating instructions



further information
webcode: GW-650TL



All rights including copyrights or industrial property rights are expressly reserved.

Keep the document for future reference.

© GEMÜ Gebr. Müller Apparatebau GmbH & Co. KG
22.04.2026

Contents

1 General information	4	17 Troubleshooting	33
1.1 Information	4	18 Inspection and maintenance	35
1.2 Symbols used	4	18.1 Spare parts	35
1.3 Definition of terms	4	18.1.1 Spare parts 0TL	35
1.4 Warning notes	4	18.1.1 Spare parts 1TL; 2TL	35
2 Safety information	5	18.2 Removing the actuator	36
3 Product description	5	18.3 Removing the diaphragm	36
3.1 Construction	5	18.4 Mounting the compressor	36
3.2 Description	5	18.5 Mounting the diaphragm	37
3.3 Function	6	18.6 Mounting the actuator	39
3.4 Control function	6	19 Disposal	39
3.5 Optical position indicator	6	20 Returns	39
4 GEMÜ CONEXO	6	21 EU Declaration of Incorporation according to the EC Machinery Directive 2006/42/EC, Annex II B ...	40
5 Correct use	6	22 Manufacturer's declaration according to the Pressure Equipment Directive 2014/68/EU	41
6 Order data	7		
6.1 Order codes	7		
6.2 Order example	9		
7 Technical data	10		
7.1 Medium	10		
7.3 Pressure	10		
7.4 Product conformity	11		
7.5 Mechanical data	11		
8 Dimensions	12		
8.1 Actuator dimensions	12		
8.2 Body dimensions of 2/2-way body	15		
8.3 Body dimensions of tank bottom valve body and T body	25		
9 Application	26		
10 Manufacturer's information	26		
10.1 Delivery	26		
10.2 Packaging	26		
10.3 Transport	26		
10.4 Storage	26		
10.5 Condition as supplied to customer	26		
11 Installation in piping	27		
11.1 Preparing for installation	27		
11.2 Installation position	27		
11.3 Installation with butt weld spigots	27		
11.4 Installation with clamp connections	28		
11.5 Installation with threaded spigots	28		
12 Pneumatic connection	28		
12.1 Control function	28		
12.2 Connecting the control medium	29		
13 Stroke limiter and seal adjuster	29		
13.1 Setting the closing limit (GEMÜ 650 0TL, 0RL, 0LL)	29		
13.2 Set closing and stroke limitation (GEMÜ 650 1TL, 1RL, 1LL, 1HL, 1ML, 1SL / 650 2TL, 2RL, 2LL, 2HL, 2ML, 2SL)	30		
14 Proximity switches	31		
14.1 Setting proximity switches	31		
14.2 Setting the damping piece	32		
15 Commissioning	32		
16 Operation	32		
16.1 Control function 1	32		

1 General information

1.1 Information

- The descriptions and instructions apply to the standard versions. For special versions not described in this document the basic information contained herein applies in combination with any additional special documentation.
- Correct installation, operation, maintenance and repair work ensure faultless operation of the product.
- Should there be any doubts or misunderstandings, the German version is the authoritative document.
- Contact us at the address on the last page for staff training information.
- A supplement to Directive 2014/34/EU (ATEX Directive) is included with the product, provided that it was ordered in accordance with ATEX.

1.2 Symbols used

The following symbols are used in this document:

Symbol	Meaning
●	Tasks to be performed
▶	Response(s) to tasks
-	Lists

1.3 Definition of terms

Working medium

The medium that flows through the GEMÜ product.

Diaphragm size

Uniform seat size of GEMÜ diaphragm valves for different nominal sizes.

Control function

The possible actuation functions of the GEMÜ product.

Control medium

The medium whose increasing or decreasing pressure causes the GEMÜ product to be actuated and operated.


1.4 Warning notes



Wherever possible, warning notes are organised according to the following scheme:



SIGNAL WORD	
Possible symbol for the specific danger	Type and source of the danger ▶ Possible consequences of non-observance. ● Measures for avoiding danger.


Warning notes are always marked with a signal word and sometimes also with a symbol for the specific danger.

The following signal words and danger levels are used:






 DANGER	
	Imminent danger! ▶ Non-observance can cause death or severe injury.

 WARNING	
	Potentially dangerous situation! ▶ Non-observance can cause death or severe injury.

 CAUTION	
	Potentially dangerous situation! ▶ Non-observance can cause moderate to light injury.

NOTICE	
	Potentially dangerous situation! ▶ Non-observance can cause damage to property.

The following symbols for the specific dangers can be used within a warning note:

Symbol	Meaning
	Danger of explosion!
	The equipment is subject to pressure!
	Corrosive chemicals!
	Hot plant components!
	Leakage!

2 Safety information

The safety information in this document refers only to an individual product. Potentially dangerous conditions can arise in combination with other plant components, which need to be considered on the basis of a risk analysis. The operator is responsible for the production of the risk analysis and for compliance with the resulting precautionary measures and regional safety regulations.

The document contains fundamental safety information that must be observed during commissioning, operation and maintenance. Non-compliance with these instructions may cause:

- Personal hazard due to electrical, mechanical and chemical effects
- Hazard to nearby equipment
- Failure of important functions
- Hazard to the environment due to the leakage of dangerous materials

The safety information does not take into account:

- Unexpected incidents and events, which may occur during installation, operation and maintenance
- Local safety regulations which must be adhered to by the operator and by any additional installation personnel

Prior to commissioning:

1. Transport and store the product correctly.
2. Do not paint the bolts and plastic parts of the product.
3. Carry out installation and commissioning using trained personnel.
4. Provide adequate training for installation and operating personnel.
5. Ensure that the contents of the document have been fully understood by the responsible personnel.
6. Define the areas of responsibility.
7. Observe the safety data sheets.
8. Observe the safety regulations for the media used.

During operation:

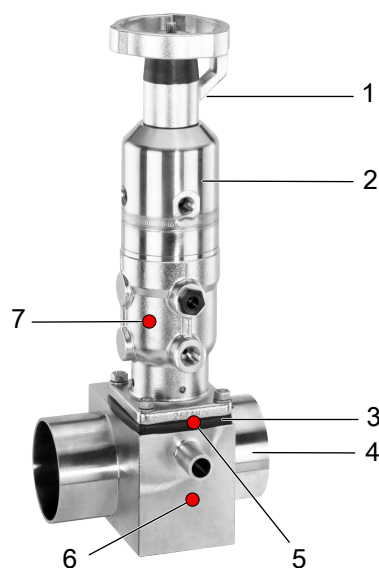
9. Keep this document available at the place of use.
10. Observe the safety information.
11. Operate the product in accordance with this document.
12. Operate the product in accordance with the specifications.
13. Maintain the product correctly.
14. Do not carry out any maintenance work and repairs not described in this document without consulting the manufacturer first.

In cases of uncertainty:

15. Consult the nearest GEMÜ sales office.

3 Product description

3.1 Construction



Item	Name	Materials
1	Handwheel	Stainless steel
2	Membrane actuator	Stainless steel
3	Diaphragm	EPDM PTFE/EPDM (one-piece, two-piece)
4	Valve body	1.4408, investment casting 1.4408, PFA lined 1.4435, investment casting 1.4435 (F316L), forged body 1.4435 (F316L), block material 1.4435 (BN2), forged body, Δ Fe < 0.5% 1.4435 (BN2), block material, Δ Fe < 0.5% 1.4539, forged body
5	CONEXO diaphragm RFID chip (see Conexo information)	
6	CONEXO body RFID chip (see Conexo information)	
7	CONEXO actuator RFID chip (see Conexo information)	

3.2 Description

Diaphragm valve GEMÜ 650TL is a manually operated diaphragm valve with a pneumatic fail safe function. The valve can only be operated manually (opened/closed) if the actu-

ator is supplied with compressed air. If this supply is interrupted, the valve closes due to the force of the spring and can no longer be opened manually.

3.3 Function

The closed position feedback of pneumatic piston and hand-wheel takes place via flush mountable proximity switches (optional). The valve has CIP/SIP cleaning and sterilizing capabilities.

3.4 Control function

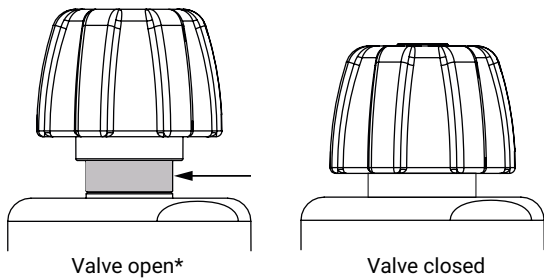
The following control functions are available:

Control function 1: Normally closed (NC)

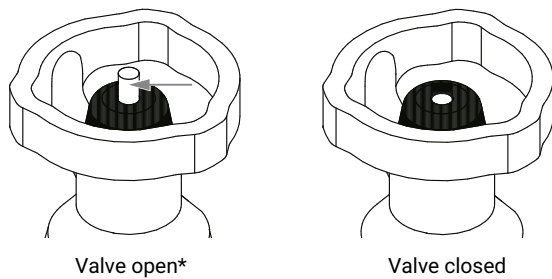
3.5 Optical position indicator

The product has an optical position indicator as standard. The optical position indicator indicates the OPEN and CLOSED positions.

GEMÜ 650 OTL



GEMÜ 650 1TL/650 2TL



* Only if control medium has been applied to the actuator and the manual actuator has been put in the OPEN position.

4 GEMÜ CONEXO

The interaction of valve components that are equipped with RFID chips and an associated IT infrastructure actively increase process reliability.



Thanks to serialization, every valve and every relevant valve component such as the body, actuator or diaphragm, and even automation components, can be clearly traced and read using the CONEXO pen RFID reader. The CONEXO app, which can be installed on mobile devices, not only facilitates and improves the "installation qualification" process, but also makes the maintenance process much more transparent and easier to document. The app actively guides the maintenance technician through the maintenance schedule and directly provides him with all the information assigned to the valve, such as test reports, testing documentation and maintenance histories. The CONEXO portal acts as a central element, helping to collect, manage and process all data.

For further information on GEMÜ CONEXO please visit:
www.gemu-group.com/conexo

5 Correct use

! DANGER	
	<p>Danger of explosion!</p> <ul style="list-style-type: none"> ▶ Risk of severe injury or death ● If there is no corresponding declaration of conformity, the product must not be used in potentially explosive atmospheres! ● Only use the product in potentially explosive zones confirmed in the declaration of conformity.
! WARNING	
<p>Improper use of the product!</p> <ul style="list-style-type: none"> ▶ Risk of severe injury or death ▶ Manufacturer liability and guarantee will be void. ● Only use the product in accordance with the operating conditions specified in the contract documentation and in this document. 	

The product is designed for installation in piping systems and for controlling a working medium.

1. Use the product in accordance with the technical data.
2. Note the supplement acc. to ATEX.
3. Please note the flow direction on the valve body.

6 Order data

Order codes

1 Type	Code
Diaphragm valve, pneumatically operated, stainless steel piston actuator electropolished, optical position indicator	650

2 DN	Code
DN 4	4
DN 6	6
DN 8	8
DN 10	10
DN 15	15
DN 20	20
DN 25	25

3 Body configuration	Code
Tank bottom valve body	B
2/2-way body	D
T body	T
Body configuration code B: Dimensions and designs on request	
Body configuration code T: Dimensions on request	

4 Connection type	Code
Spigot	
Spigot DIN	0
Spigot DIN EN 10357 series B (2014 edition; formerly DIN 11850 series 1)	16
Spigot EN 10357 series A/DIN 11866 series A, formerly DIN 11850 series 2	17
Spigot DIN 11850 series 3	18
Spigot JIS-G 3447	35
Spigot JIS-G 3459 schedule 10s	36
Spigot SMS 3008	37
Spigot BS 4825, Part 1	55
Spigot ASME BPE/DIN EN 10357 series C (from 2022 issue)/DIN 11866 series C	59
Spigot ISO 1127/DIN EN 10357 series C (2014 issue)/DIN 11866 series B	60
Spigot ANSI/ASME B36.19M schedule 10s	63
Spigot ANSI/ASME B36.19M schedule 5s	64
Spigot ANSI/ASME B36.19M schedule 40s	65
Threaded connection	
Threaded spigot DIN 11851	6
Cone spigot and union nut DIN 11851	6K
Clamp	
Clamp ASME BPE, face-to-face dimension FTF ASME BPE, length only for body configuration D	80
Clamp DIN 32676 series B, face-to-face dimension FTF EN 558 series 7, length only for body configuration D	82

4 Connection type	Code
Clamp ASME BPE, for pipe ASME BPE, face-to-face dimension FTF EN 558 series 7, length only for body configuration D	88
Clamp DIN 32676 series A, face-to-face dimension FTF acc. to EN 558 series 7, length only for body configuration D	8A
Clamp ISO 2852 for pipe ISO 2037, clamps SMS 3017 for pipe SMS 3008, face-to-face dimension FTF EN 558 series 7, length only for body configuration D	8E
Clamp DIN 32676 series C, face-to-face dimension FTF ASME BPE, length only for body configuration D	8P
Clamp DIN 32676 series C, face-to-face dimension FTF EN 558 series 7, length only for body configuration D	8T

5 Valve body material	Code
1.4408, PFA lined	39
1.4435 (F316L), forged body	40
1.4435 (316L), block material	41
1.4435 (BN2), forged body, $\Delta Fe < 0.5\%$	42
1.4435 (BN2), block material, $\Delta Fe < 0.5\%$	43
1.4435, investment casting	C3
1.4539 / UNS N08904, forged body	F4

6 Diaphragm material	Code
EPDM	13
EPDM	3A
EPDM	17
EPDM	19
PTFE/EPDM one-piece	54
PTFE/EPDM two-piece	5M
Note: The PTFE/EPDM diaphragm (code 5M) is available from diaphragm size 10.	
Note: The EPDM diaphragm (code 3A) is only available for diaphragm size 8.	

7 Control function	Code
Normally closed (NC)	1

8 Actuator version	Code
DN 4 - 15, diaphragm size 8	
Manually operated with automatic closing function, control air connector and connections for proximity switches positioned 90° offset to flow direction	0LL
Manually operated with automatic closing function, control air connector and connections for proximity switches positioned in-line with flow direction	0TL

8 Actuator version	Code
Manually operated with automatic closing function, control air connector positioned 90° offset to flow direction, connections for proximity switches in-line with flow direction	0RL
DN 10–20, diaphragm size 10	
Manually operated with automatic closing function, control air connector and connections for proximity switches positioned in-line with flow direction	1HL
Manually operated with automatic closing function, control air connector and connections for proximity switches positioned 90° offset to flow direction	1LL
Manually operated with automatic closing function, control air connector and connections for proximity switches positioned 90° offset to flow direction	1ML
Manually operated with automatic closing function, control air connector positioned 90° offset to flow direction, connections for proximity switches in-line with flow direction	1RL
Manually operated with automatic closing function, control air connector positioned 90° offset to flow direction, connections for proximity switches in-line with flow direction	1SL
Manually operated with automatic closing function, control air connector and connections for proximity switches positioned in-line with flow direction	1TL
DN 15 - 25, diaphragm size 25	
Manually operated with automatic closing function, control air connector and connections for proximity switches positioned in-line with flow direction	2HL
Manually operated with automatic closing function, control air connector and connections for proximity switches positioned 90° offset to flow direction	2LL
Manually operated with automatic closing function, control air connector and connections for proximity switches positioned 90° offset to flow direction	2ML
Manually operated with automatic closing function, control air connector positioned 90° offset to flow direction, connections for proximity switches in-line with flow direction	2RL
Manually operated with automatic closing function, control air connector positioned 90° offset to flow direction, connections for proximity switches in-line with flow direction	2SL
Manually operated with automatic closing function, control air connector and connections for proximity switches positioned in-line with flow direction	2TL
9 DN-2	Code
DN 4	4

9 DN-2	Code
DN 6	6
DN 8	8
DN 10	10
DN 15	15
DN 20	20
DN 25	25

10 Connection type for T body	Code
Spigot	
Spigot DIN	0
Spigot DIN EN 10357 series B (2014 edition; formerly DIN 11850 series 1)	16
Spigot EN 10357 series A/DIN 11866 series A, formerly DIN 11850 series 2	17
Spigot DIN 11850 series 3	18
Spigot JIS-G 3447	35
Spigot JIS-G 3459 schedule 10s	36
Spigot SMS 3008	37
Spigot BS 4825, Part 1	55
Spigot ASME BPE/DIN EN 10357 series C (from 2022 issue)/DIN 11866 series C	59
Spigot ISO 1127/DIN EN 10357 series C (2014 issue)/DIN 11866 series B	60
Spigot ANSI/ASME B36.19M schedule 10s	63
Spigot ANSI/ASME B36.19M schedule 5s	64
Spigot ANSI/ASME B36.19M schedule 40s	65
Threaded connection	
Threaded spigot DIN 11851	6
Cone spigot and union nut DIN 11851	6K
Clamp	
Clamp ASME BPE, face-to-face dimension FTF ASME BPE, length only for body configuration D	80
Clamp DIN 32676 series B, face-to-face dimension FTF EN 558 series 7, length only for body configuration D	82
Clamp ASME BPE, for pipe ASME BPE, face-to-face dimension FTF EN 558 series 7, length only for body configuration D	88
Clamp DIN 32676 series A, face-to-face dimension FTF acc. to EN 558 series 7, length only for body configuration D	8A
Clamp ISO 2852 for pipe ISO 2037, clamps SMS 3017 for pipe SMS 3008, face-to-face dimension FTF EN 558 series 7, length only for body configuration D	8E
Clamp DIN 32676 series C, face-to-face dimension FTF ASME BPE, length only for body configuration D	8P
Clamp DIN 32676 series C, face-to-face dimension FTF EN 558 series 7, length only for body configuration D	8T

11 Surface	Code
Ra ≤ 6.3 µm for media wetted surfaces, mechanically polished internal	1500

11 Surface	Code
Ra ≤ 0.8 µm for media wetted surfaces, in accordance with DIN 11866 H3, mechanically polished internal	1502
Ra ≤ 0.8 µm for media wetted surfaces, in accordance with DIN 11866 HE3, electropolished internal/external	1503
Ra ≤ 0.6 µm for media wetted surfaces, mechanically polished internal	1507
Ra ≤ 0.6 µm for media wetted surfaces, electropolished internal/external	1508
Ra ≤ 0.25 µm for media wetted surfaces *), in accordance with DIN 11866 HE5, electropolished internal/external, *) for inner pipe diameter ≤ 6 mm, in spigot Ra ≤ 0.38 µm	1516
Ra ≤ 0.25 µm for media wetted surfaces *), in accordance with DIN 11866 H5, mechanically polished internal, *) for inner pipe diameter < 6 mm, in spigots Ra ≤ 0.38 µm	1527
Ra ≤ 0.4 µm for media wetted surfaces, in accordance with DIN 11866 H4, mechanically polished internal	1536
Ra ≤ 0.4 µm for media wetted surfaces, in accordance with DIN 11866 HE4, electropolished internal/external	1537
Ra max. 0.51 µm (20 µin.) for media wetted surfaces, in accordance with ASME BPE SF1, mechanically polished internal	SF1

11 Surface	Code
Ra max. 0.64 µm (25 µin.) for media wetted surfaces, in accordance with ASME BPE SF2, mechanically polished internal	SF2
Ra max. 0.76 µm (30 µin.) for media wetted surfaces, in accordance with ASME BPE SF3, mechanically polished internal	SF3
Ra max. 0.38 (15 µin.) µm for media wetted surfaces, in accordance with ASME BPE SF4, electropolished internal/external	SF4
Ra max. 0.51 µm (20 µin.) for media wetted surfaces, in accordance with ASME BPE SF5, electropolished internal/external	SF5
Ra max. 0.64 µm (25 µin.) for media wetted surfaces, in accordance with ASME BPE SF6, electropolished internal/external	SF6

12 Special version	Code
Without	
Special version for 3A	M
Special version for oxygen, maximum medium temperature: 60 °C	S

13 CONEXO	Code
Without	
Integrated RFID chip for electronic identification and traceability	C

Order example

Ordering option	Code	Description
1 Type	650	Diaphragm valve, pneumatically operated, stainless steel piston actuator electropolished, optical position indicator
2 DN	25	DN 25
3 Body configuration	T	T body
4 Connection type	60	Spigot ISO 1127/DIN EN 10357 series C (2014 issue)/DIN 11866 series B
5 Valve body material	41	1.4435 (316L), block material
6 Diaphragm material	17	EPDM
7 Control function	1	Normally closed (NC)
8 Actuator version	2SL	Manually operated with automatic closing function, control air connector positioned 90° offset to flow direction, connections for proximity switches in-line with flow direction
9 DN-2	25	DN 25
10 Connection type for T body	60	Spigot ISO 1127/DIN EN 10357 series C (2014 issue)/DIN 11866 series B
11 Surface	1503	Ra ≤ 0.8 µm for media wetted surfaces, in accordance with DIN 11866 HE3, electropolished internal/external
12 Special version	M	Special version for 3A
13 CONEXO		Without

7 Technical data

7.1 Medium

Working medium: Corrosive, inert, gaseous and liquid media which have no negative impact on the physical and chemical properties of the body and diaphragm material.

Control medium: Inert gases

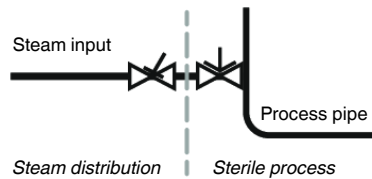
7.2 Temperature

Media temperature: -10 – 100 °C
For special function S: 0 – 60 °C

Sterilization temperature:

EPDM (code 3A/13)	max. 150 °C, max. 60 min per cycle
EPDM (code 17)	max. 150 °C, max. 180 min per cycle
EPDM (code 19)	max. 150 °C, max. 180 min per cycle
PTFE/EPDM (code 54)	max. 150 °C, constant temperature per cycle
PTFE/EPDM (code 5M)	max. 150 °C, constant temperature per cycle

The sterilization temperature is only valid for steam (saturated steam) or superheated water. If the sterilization temperatures listed above are applied to the EPDM diaphragms for longer periods of time, the service life of the diaphragms will be reduced. In these cases, maintenance cycles must be adapted accordingly. PTFE diaphragms can also be used as steam barriers; however, this will reduce their service life. This also applies to PTFE diaphragms exposed to high temperature fluctuations. The maintenance cycles must be adapted accordingly. GEMÜ 555 and 505 globe valves are particularly suitable for use in the area of steam generation and distribution. The following valve arrangement for interfaces between steam pipes and process pipes has proven itself over time: A globe valve for shutting off steam pipes and a diaphragm valve as an interface to the process pipes.



Ambient temperature: 0 – 60 °C

Control medium temperature: max. 60 °C

Storage temperature: 0 – 40 °C

7.3 Pressure

Operating pressure:

Actuator version	DN	MG	Operating pressure	
			EPDM	PTFE
0TL, 0RL, 0LL	4 - 15	8	0 - 8	0 - 6
1TL, 1RL, 1LL	10 - 20	10	0 - 5	0 - 5
1HL, 1ML, 1SL			0 - 10	0 - 10
2TL, 2RL, 2LL	15 - 25	25	0 - 5	0 - 5
2HL, 2ML, 2SL			0 - 10	0 - 10

All pressures are gauge pressures. Operating pressure values were determined with static operating pressure applied on one side of a closed valve. Sealing at the valve seat and atmospheric sealing is ensured for the given values.

Information on operating pressures applied on both sides and for high purity media on request.

Control pressure:**Control function 1**

Actuator version	DN	MG	Control pressure
0TL, 0RL, 0LL	4 - 15	8	5.0 - 7.0
1TL, 1RL, 1LL	10 - 20	10	5.0 - 7.0
1HL, 1ML, 1SL			5.0 - 8.0
2TL, 2RL, 2LL	15 - 25	25	4.0 - 7.0
2HL, 2ML, 2SL			5.0 - 8.0

All pressures are gauge pressures.
MG = diaphragm size

Filling volume:**Control function 1**

Actuator version	DN	MG	Filling volume [dm ³]
0TL, 0RL, 0LL	4 - 15	8	0.01
1TL, 1RL, 1LL, 1HL, 1ML, 1SL	10 - 20	10	0.02
2TL, 2RL, 2LL, 2HL, 2ML, 2SL	15 - 25	25	0.06

7.4 Product conformity

Pressure Equipment Directive: 2014/68/EU

Machinery Directive: 2006/42/EC

Food: FDA
Regulation (EC) No. 1935/2004
Regulation (EC) No. 10/2011
Regulation (EC) No. 2023/2006
USP Class VI
CRN
* depending on version and/or operating parameters

Oxygen: BAM compliant, the product is suitable for application with oxygen (special version code S)

TA Luft (German Clean Air Act): The product complies with the equivalence requirements of section 5.2.6.4 of the German Clean Air Act (TA Luft / VDI 2440 according to section 3.3.1.3)

EAC: The product is certified according to EAC.

7.5 Mechanical data

Installation position: Optional
Observe the angle of rotation for optimized draining when it comes to installation. See separate document, "Angle of rotation technical information".

8 Dimensions

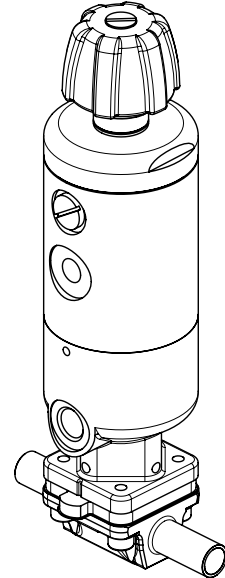
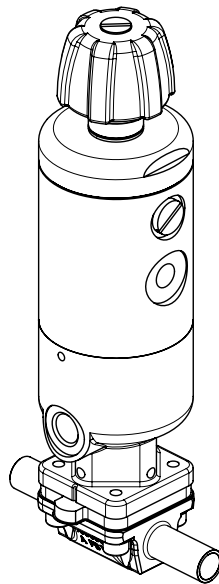
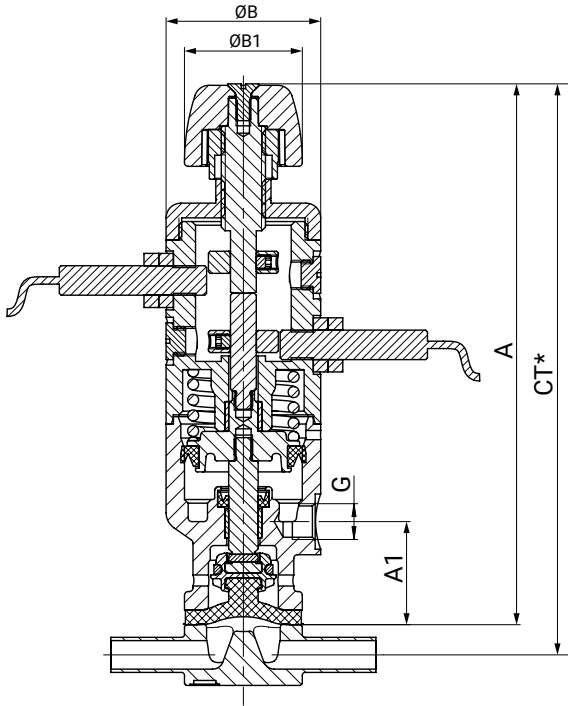
8.1 Actuator dimensions

8.1.1 Actuator version OTL, ORL, OLL

Actuator version OTL
control air connector and connections
for proximity switches
positioned in-line with flow direction

Actuator version ORL
control air connector positioned 90°
offset to flow direction,
connections for proximity switches
positioned in-line with flow direction

Actuator version OLL
control air connector and connections
for proximity switches positioned 90°
offset to flow direction

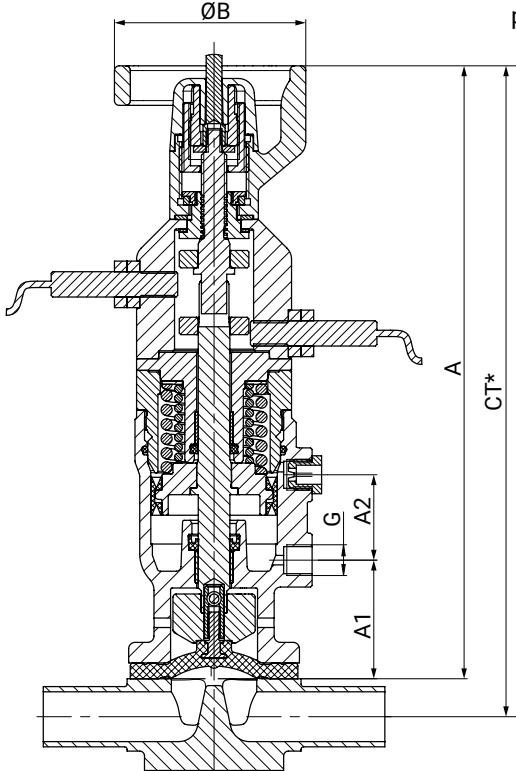


Actuator version	MG	A	A1	A2	ØB	ØB1	G
OTL, ORL, OLL	8	146.0	26.5	-	42.0	32.0	G 1/8

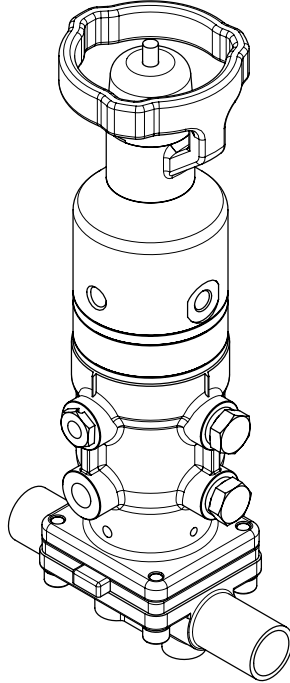
Dimensions in mm
MG = diaphragm size
* CT = A + H1 (see body dimensions)

8.1.2 Actuator version 1TL, 1HL, 1RL, 1SL, 1LL, 1ML

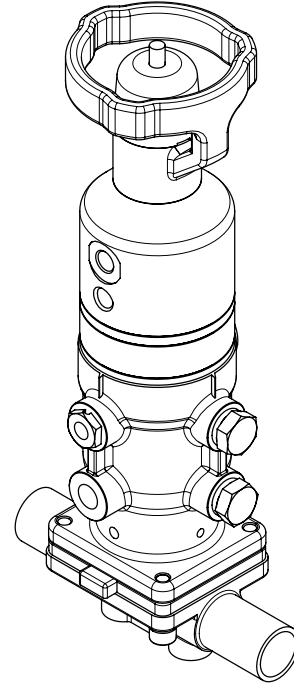
Actuator version 1TL, 1HL
control air connector and connections
for proximity switches positioned in-line
with flow direction



Actuator version 1RL, 1SL
control air connector positioned 90°
offset to flow direction,
connections for proximity switches
positioned in-line with flow direction



Actuator version 1LL, 1ML
control air connector and connections
for proximity switches positioned 90°
offset to flow direction



Actuator version	MG	A	A1	A2	ØB	ØB1	G
1TL, 1RL, 1LL, 1HL, 1ML, 1SL	10	196.0	37.0	27.0	60.0	-	G 1/8

Dimensions in mm

MG = diaphragm size

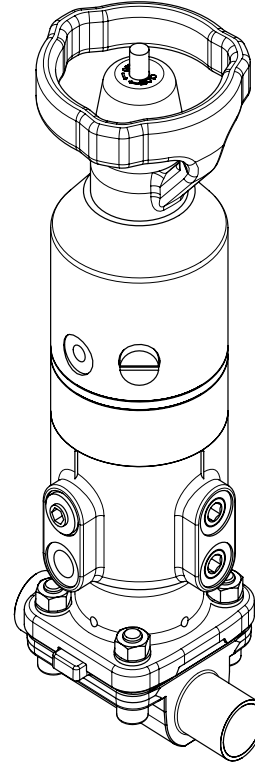
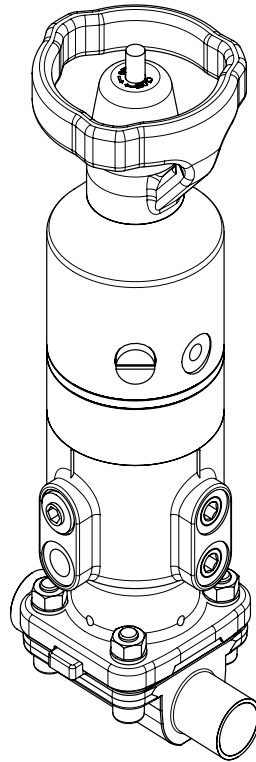
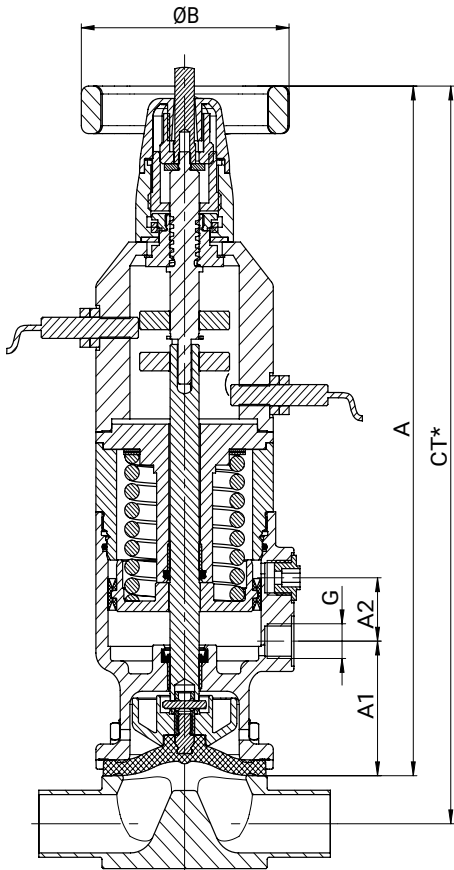
* CT = A + H1 (see body dimensions)

8.1.3 Actuator version 2TL, 2HL, 2RL, 2SL, 2LL, 2ML

Actuator version 2TL, 2HL
Pilot air connection and connections for proximity switches in flow direction

Actuator version 2RL, 2SL
Pilot air connection 90° to the direction of flow,
Connections for proximity switches in flow direction

Actuator version 2LL, 2ML
Control air connection and connections for proximity switches 90° to the flow direction

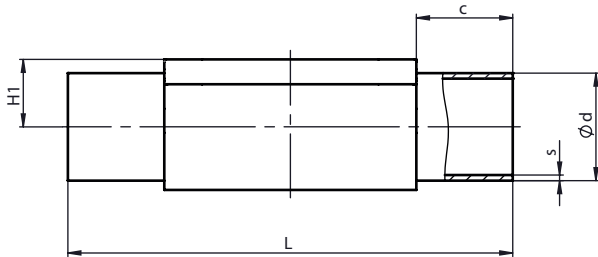


Actuator version	MG	A	A1	A2	ØB	ØB1	G
2TL, 2RL, 2LL, 2HL, 2ML, 2SL	25	264.0	51.0	24.0	85.0	-	G 1/4

Dimensions in mm
MG = diaphragm size
* CT = A + H1 (see body dimensions)

8.2 Body dimensions of 2/2-way body

8.2.1 Spigot DIN/EN/ISO (code 0, 16, 17, 18, 60)



Connection type spigot DIN/EN/ISO (code 0, 16, 17, 18, 60)¹⁾, forged material (code 40, 42, F4)²⁾

MG	DN	NPS	c (min)	Ød					H1	L	s				
				Connection type							Connection type				
				0	16	17	18	60			0	16	17	18	60
8	4	-	20.0	6.0	-	-	-	-	8.5	72.0	1.0	-	-	-	-
	6	-	20.0	-	-	8.0	-	10.2	8.5	72.0	-	-	1.0	-	1.6
	8	1/4"	20.0	-	-	10.0	-	13.5	8.5	72.0	-	-	1.0	-	1.6
	10	3/8"	20.0	-	12.0	13.0	14.0	-	8.5	72.0	-	1.0	1.5	2.0	-
10	10	3/8"	25.0	-	12.0	13.0	14.0	17.2	12.5	108.0	-	1.0	1.5	2.0	1.6
	15	1/2"	25.0	18.0	18.0	19.0	20.0	21.3	12.5	108.0	1.5	1.0	1.5	2.0	1.6
25	15	1/2"	25.0	18.0	18.0	19.0	20.0	21.3	19.0	120.0	1.5	1.0	1.5	2.0	1.6
	20	3/4"	25.0	22.0	22.0	23.0	24.0	26.9	19.0	120.0	1.5	1.0	1.5	2.0	1.6
	25	1"	25.0	28.0	28.0	29.0	30.0	33.7	19.0	120.0	1.5	1.0	1.5	2.0	2.0

Dimensions in mm

MG = diaphragm size

1) Connection type

Code 0: Spigot DIN

Code 16: Spigot DIN EN 10357 series B (2014 edition; formerly DIN 11850 series 1)

Code 17: Spigot EN 10357 series A/DIN 11866 series A, formerly DIN 11850 series 2

Code 18: Spigot DIN 11850 series 3

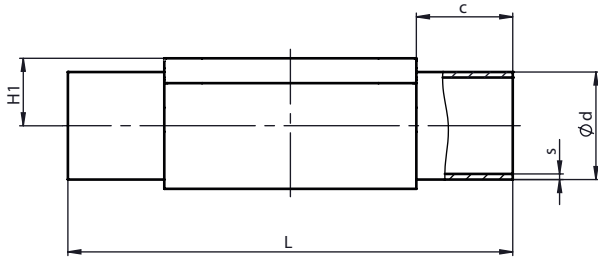
Code 60: Spigot ISO 1127/DIN EN 10357 series C (2014 issue)/DIN 11866 series B

2) Valve body material

Code 40: 1.4435 (F316L), forged body

Code 42: 1.4435 (BN2), forged body, Δ Fe < 0.5%

Code F4: 1.4539 / UNS N08904, forged body



Connection type spigot DIN/EN/ISO (code 0, 17, 60)¹⁾, investment casting material (code C3)²⁾

MG	DN	NPS	c (min)	Ød			H1	L	s		
				Connection type					Connection type		
				0	17	60			0	17	60
8	4	-	20.0	6.0	-	-	8.5	72.0	1.0	-	-
	6	-	20.0	-	8.0	-	8.5	72.0	-	1.0	-
	8	1/4"	20.0	-	10.0	13.5	8.5	72.0	-	1.0	1.6
	10	3/8"	20.0	-	13.0	-	8.5	72.0	-	1.5	-
10	10	3/8"	25.0	-	13.0	17.2	12.5	108.0	-	1.5	1.6
	15	1/2"	25.0	-	19.0	21.3	12.5	108.0	-	1.5	1.6
25	15	1/2"	25.0	-	19.0	21.3	13.0	120.0	-	1.5	1.6
	20	3/4"	25.0	-	23.0	26.9	16.0	120.0	-	1.5	1.6
	25	1"	25.0	-	29.0	33.7	19.0	120.0	-	1.5	2.0

Dimensions in mm

MG = diaphragm size

1) **Connection type**

Code 0: Spigot DIN

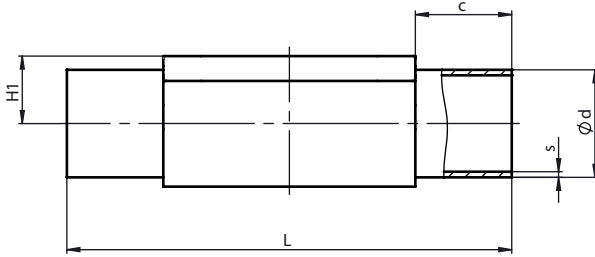
Code 17: Spigot EN 10357 series A/DIN 11866 series A, formerly DIN 11850 series 2

Code 60: Spigot ISO 1127/DIN EN 10357 series C (2014 issue)/DIN 11866 series B

2) **Valve body material**

Code C3: 1.4435, investment casting

8.2.2 Spigot ASME/BS (code 55, 59, 63, 64, 65)



Connection type spigot ASME/BS (code 55, 59, 63, 64, 65)¹⁾, forged material (code 40, 42, F4)²⁾

MG	DN	NPS	c (min)	Ød					H1	L	s				
				Connection type							Connection type				
				55	59	63	64	65			55	59	63	64	65
8	6	-	20.0	-	-	10.3	-	10.3	8.5	72.0	-	-	1.24	-	1.73
	8	1/4"	20.0	6.35	6.35	13.7	-	13.7	8.5	72.0	1.2	0.89	1.65	-	2.24
	10	3/8"	20.0	9.53	9.53	-	-	-	8.5	72.0	1.2	0.89	-	-	-
	15	1/2"	20.0	12.70	12.70	-	-	-	8.5	72.0	1.2	1.65	-	-	-
10	10	3/8"	25.0	9.53	9.53	17.1	-	17.1	12.5	108.0	1.2	0.89	1.65	-	2.31
	15	1/2"	25.0	12.70	12.70	21.3	21.3	21.3	12.5	108.0	1.2	1.65	2.11	1.65	2.77
	20	3/4"	25.0	19.05	19.05	-	-	-	12.5	108.0	1.2	1.65	-	-	-
25	15	1/2"	25.0	-	-	21.3	21.3	21.3	19.0	120.0	-	-	2.11	1.65	2.77
	20	3/4"	25.0	19.05	19.05	26.7	26.7	26.7	19.0	120.0	1.2	1.65	2.11	1.65	2.87
	25	1"	25.0	-	25.40	33.4	33.4	33.4	19.0	120.0	-	1.65	2.77	1.65	3.38

Dimensions in mm

MG = diaphragm size

1) Connection type

Code 55: Spigot BS 4825, Part 1

Code 59: Spigot ASME BPE/DIN EN 10357 series C (from 2022 issue)/DIN 11866 series C

Code 63: Spigot ANSI/ASME B36.19M schedule 10s

Code 64: Spigot ANSI/ASME B36.19M schedule 5s

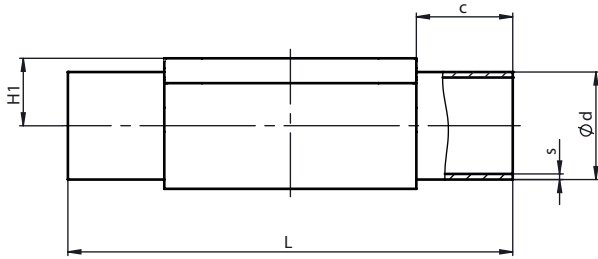
Code 65: Spigot ANSI/ASME B36.19M schedule 40s

2) Valve body material

Code 40: 1.4435 (F316L), forged body

Code 42: 1.4435 (BN2), forged body, Δ Fe < 0.5%

Code F4: 1.4539 / UNS N08904, forged body



Connection type spigot ASME BPE (code 59)¹⁾, investment casting material (code C3)²⁾

MG	DN	NPS	c (min)	Ød	H1	L	s
8	8	1/4"	20.0	6.35	8.5	72.0	0.89
	10	3/8"	20.0	9.53	8.5	72.0	0.89
	15	1/2"	20.0	12.70	8.5	72.0	1.65
10	20	3/4"	25.0	19.05	12.5	108.0	1.65
25	20	3/4"	25.0	19.05	16.0	120.0	1.65
	25	1"	25.0	25.40	19.0	120.0	1.65

Dimensions in mm

MG = diaphragm size

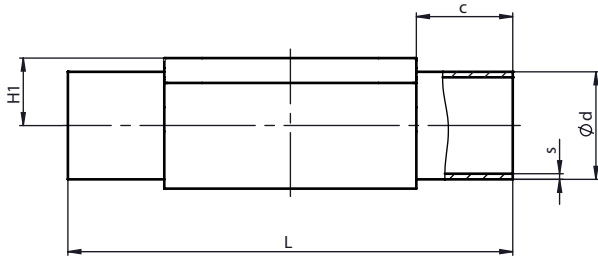
1) **Connection type**

Code 59: Spigot ASME BPE/DIN EN 10357 series C (from 2022 issue)/DIN 11866 series C

2) **Valve body material**

Code C3: 1.4435, investment casting

8.2.3 Spigot JIS/SMS (code 35, 36, 37)



Connection type spigot JIS/SMS (code 35, 36, 37)¹⁾, forged material (code 40, 42, F4)²⁾

MG	DN	NPS	c (min)	Ød			H1	L	s		
				Connection type					Connection type		
				35	36	37			35	36	37
8	6	-	20.0	-	10.5	-	8.5	72.0	-	1.20	-
	8	1/4"	20.0	-	13.8	-	8.5	72.0	-	1.65	-
10	10	3/8"	25.0	-	17.3	-	12.5	108.0	-	1.65	-
	15	1/2"	25.0	-	21.7	-	12.5	108.0	-	2.10	-
25	15	1/2"	25.0	-	21.7	-	19.0	120.0	-	2.10	-
	20	3/4"	25.0	-	27.2	-	19.0	120.0	-	2.10	-
	25	1"	25.0	25.4	34.0	25.0	19.0	120.0	1.2	2.80	1.2

Connection type spigot SMS (code 37)¹⁾, investment casting material (code C3)²⁾

MG	DN	NPS	c (min)	Ød	H1	L	s
25	25	1"	25.0	25.0	19.0	120.0	1.2

Dimensions in mm

MG = diaphragm size

1) Connection type

Code 35: Spigot JIS-G 3447

Code 36: Spigot JIS-G 3459 schedule 10s

Code 37: Spigot SMS 3008

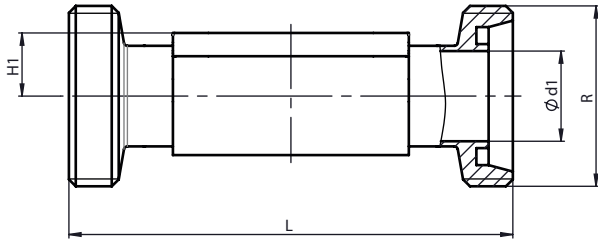
2) Valve body material

Code 40: 1.4435 (F316L), forged body

Code 42: 1.4435 (BN2), forged body, Δ Fe < 0.5%

Code C3: 1.4435, investment casting

Code F4: 1.4539 / UNS N08904, forged body

8.2.4 Threaded spigot DIN (code 6)**Connection type threaded spigot DIN (code 6)¹⁾, forged material (code 40, 42)²⁾**

MG	DN	NPS	Ød1	H1	L	R
8	10	3/8"	10.0	8.5	92.0	Rd 28 x 1/8
10	10	3/8"	10.0	12.5	118.0	Rd 28 x 1/8
	15	1/2"	16.0	12.5	118.0	Rd 34 x 1/8
25	15	1/2"	16.0	19.0	118.0	Rd 34 x 1/8
	20	3/4"	20.0	19.0	118.0	Rd 44 x 1/6
	25	1"	26.0	19.0	128.0	Rd 52 x 1/6

Dimensions in mm

MG = diaphragm size

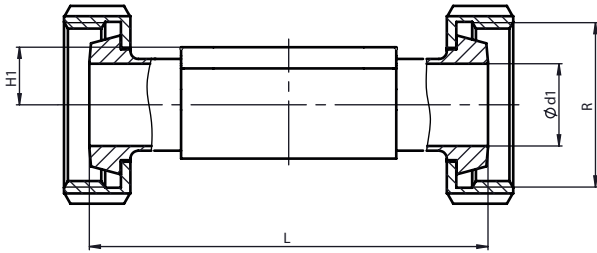
1) Connection type

Code 6: Threaded spigot DIN 11851

2) Valve body material

Code 40: 1.4435 (F316L), forged body

Code 42: 1.4435 (BN2), forged body, Δ Fe < 0.5%

8.2.5 Cone spigot DIN (code 6K)**Connection type cone spigot DIN (code 6K)¹⁾, forged material (code 40, 42)²⁾**

MG	DN	NPS	ød1	H1	L	R
8	10	3/8"	10.0	8.5	90.0	Rd 28 x 1/8
10	10	3/8"	10.0	12.5	116.0	Rd 28 x 1/8
	15	1/2"	16.0	12.5	116.0	Rd 34 x 1/8
25	15	1/2"	16.0	19.0	116.0	Rd 34 x 1/8
	20	3/4"	20.0	19.0	114.0	Rd 44 x 1/6
	25	1"	26.0	19.0	127.0	Rd 52 x 1/6

Dimensions in mm

MG = diaphragm size

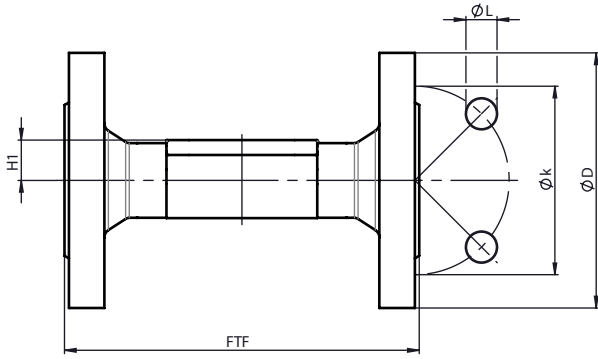
1) Connection type

Code 6K: Cone spigot and union nut DIN 11851

2) Valve body material

Code 40: 1.4435 (F316L), forged body

Code 42: 1.4435 (BN2), forged body, $\Delta Fe < 0.5\%$

8.2.6 Flange EN (code 8)**Connection type flange, length EN 558 (code 8)¹⁾, investment casting material (code 39, C3), forged material (code 40, 42)²⁾**

MG	DN	NPS	øD	FTF			H1			øk	øL	n
				Material			Material					
				39	C3	40, 42	39	C3	40, 42			
25	15	1/2"	95.0	130.0	150.0	150.0	18.0	13.0	19.0	65.0	14.0	4
	20	3/4"	105.0	150.0	150.0	150.0	20.5	16.0	19.0	75.0	14.0	4
	25	1"	115.0	160.0	160.0	160.0	23.0	19.0	19.0	85.0	14.0	4

Dimensions in mm

MG = diaphragm size

n = number of bolts

1) Connection type

Code 8: Flange EN 1092, PN 16, form B, face-to-face dimension FTF EN 558 series 1, ISO 5752, basic series 1, length only for body configuration D

2) Valve body material

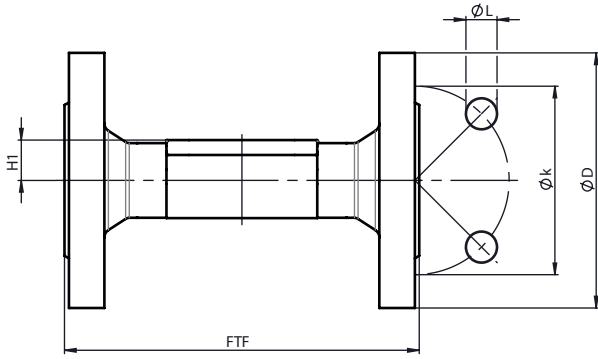
Code 39: 1.4408, PFA lined

Code 40: 1.4435 (F316L), forged body

Code 42: 1.4435 (BN2), forged body, $\Delta Fe < 0.5\%$

Code C3: 1.4435, investment casting

8.2.7 Flange ANSI Class (code 38, 39)



Connection type flange, length MSS SP-88 (code 38)¹⁾, investment casting material (code 39)²⁾

MG	DN	NPS	øD	FTF	H1	øk	øL	n
25	20	3/4"	100.0	146.0	20.5	69.9	15.9	4
	25	1"	110.0	146.0	23.0	79.4	15.9	4

Dimensions in mm

MG = diaphragm size

n = number of bolts

1) Connection type

Code 38: Flange ANSI Class 150 RF, face-to-face dimension FTF MSS SP-88, length only for body configuration D

2) Valve body material

Code 39: 1.4408, PFA lined

Connection type flange, length EN 558 (code 39)¹⁾, investment casting material (code 39, C3), forged material (code 40, 42)²⁾

MG	DN	NPS	øD	FTF		H1			øk	øL	n
				Material		Material					
				39, 40, 42	C3	39	C3	40, 42			
25	15	1/2"	90.0	130.0	150.0	-	13.0	19.0	60.3	15.9	4
	20	3/4"	100.0	150.0	150.0	20.5	16.0	19.0	69.9	15.9	4
	25	1"	110.0	160.0	160.0	23.0	19.0	19.0	79.4	15.9	4

Dimensions in mm

MG = diaphragm size

n = number of bolts

1) Connection type

Code 39: Flange ANSI Class 125/150 RF, face-to-face dimension FTF EN 558 series 1, ISO 5752, basic series 1, length only for body configuration D

2) Valve body material

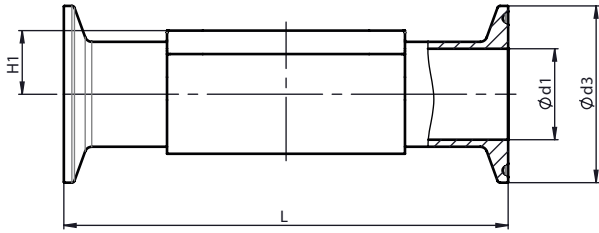
Code 39: 1.4408, PFA lined

Code 40: 1.4435 (F316L), forged body

Code 42: 1.4435 (BN2), forged body, Δ Fe < 0.5%

Code C3: 1.4435, investment casting

8.2.8 Clamp DIN/ISO/ASME (code 80, 82, 88, 8A, 8E, 8P, 8T)



Connection type clamp DIN/ASME (code 80, 88, 8P, 8T)¹⁾, forged material (code 40, 42, F4)²⁾

MG	DN	NPS	$\phi d1$		$\phi d3$		H1	L	
			Connection type		Connection type			Connection type	
			80, 8P	88, 8T	80, 8P	88, 8T		80, 8P	88, 8T
8	8	1/4"	4.57	-	25.0	-	8.5	63.5	-
	10	3/8"	7.75	-	25.0	-	8.5	63.5	-
	15	1/2"	9.40	9.40	25.0	25.0	8.5	63.5	108.0
10	15	1/2"	9.40	9.40	25.0	25.0	12.5	88.9	108.0
	20	3/4"	15.75	15.75	25.0	25.0	12.5	101.6	117.0
25	20	3/4"	15.75	15.75	25.0	25.0	19.0	101.6	117.0
	25	1"	22.10	22.10	50.5	50.5	19.0	114.3	127.0

Dimensions in mm

MG = diaphragm size

1) Connection type

Code 80: Clamp ASME BPE, face-to-face dimension FTF ASME BPE, length only for body configuration D

Code 88: Clamp ASME BPE, for pipe ASME BPE, face-to-face dimension FTF EN 558 series 7, length only for body configuration D

Code 8P: Clamp DIN 32676 series C, face-to-face dimension FTF ASME BPE, length only for body configuration D

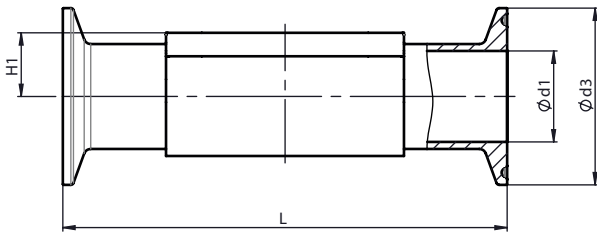
Code 8T: Clamp DIN 32676 series C, face-to-face dimension FTF EN 558 series 7, length only for body configuration D

2) Valve body material

Code 40: 1.4435 (F316L), forged body

Code 42: 1.4435 (BN2), forged body, $\Delta Fe < 0.5\%$

Code F4: 1.4539 / UNS N08904, forged body



Connection type clamp DIN/ISO (code 82, 8A, 8E)¹⁾, forged material (code 40, 42, F4)²⁾

MG	DN	NPS	ød1			ød3			H1	L		
			Connection type			Connection type				Connection type		
			82	8A	8E	82	8A	8E		82	8A	8E
8	6	1/8"	7.0	6.0	-	25.0	25.0	-	8.5	63.5	63.5	-
	8	1/4"	10.3	8.0	-	25.0	25.0	-	8.5	63.5	63.5	-
	10	3/8"	-	10.0	-	-	34.0	-	8.5	-	88.9	-
10	10	3/8"	14.0	10.0	-	25.0	34.0	-	12.5	108.0	108.0	-
	15	1/2"	18.1	16.0	-	50.5	34.0	-	12.5	108.0	108.0	-
25	15	1/2"	18.1	16.0	-	50.5	34.0	-	19.0	108.0	108.0	-
	20	3/4"	23.7	20.0	-	50.5	34.0	-	19.0	117.0	117.0	-
	25	1"	29.7	26.0	22.6	50.5	50.5	50.5	19.0	127.0	127.0	127.0

Dimensions in mm

MG = diaphragm size

1) **Connection type**

Code 82: Clamp DIN 32676 series B, face-to-face dimension FTF EN 558 series 7, length only for body configuration D

Code 8A: Clamp DIN 32676 series A, face-to-face dimension FTF acc. to EN 558 series 7, length only for body configuration D

Code 8E: Clamp ISO 2852 for pipe ISO 2037, clamps SMS 3017 for pipe SMS 3008, face-to-face dimension FTF EN 558 series 7, length only for body configuration D

2) **Valve body material**

Code 40: 1.4435 (F316L), forged body

Code 42: 1.4435 (BN2), forged body, Δ Fe < 0.5%

Code F4: 1.4539 / UNS N08904, forged body

8.3 Body dimensions of tank bottom valve body and T body

Tank bottom valve body and T body: Dimensions and designs on request

9 Application

If the flow velocity in the loop reduces (e.g. because too many take-off points are opened) and thus drops below a critical value, the process monitoring system is notified about this by sensors. If this special valve is applied to the facility, these take-off points can be selectively chosen and automatically closed via the central process monitoring system.

To achieve this, the control medium supply, which keeps the pneumatic actuators in the open position, is interrupted and all manually opened valves automatically adopt the closed position (fail-safe condition). This fail-safe condition overrides the position of the manual handwheel. This reduces the quantity being tapped at the usage points and the flow velocity in the ring main increases back to the required value.

In this resting position (i.e. control medium supply = off/valve closed), the handwheel then has to be turned clockwise all the way to the closed position. This means that the valve can only be reopened by manual operation when the control medium is switched back on. This prevents the actuator from assuming the previous open position if the control medium supply is switched on.

It is important to state in the work instruction that, if the control medium supply is shut off, the valves must be manually closed. This prevents the working medium from flowing out at the take-off points in an uncontrolled manner after switching the control medium supply back on. The handwheel has no direct function when the control medium supply is shut off. However, it does determine the valve position when the control medium supply is switched back on.

10 Manufacturer's information

10.1 Delivery

- Check that all parts are present and check for any damage immediately upon receipt.

The product's performance is tested at the factory. The scope of delivery is apparent from the dispatch documents and the design from the order number.

10.2 Packaging

The product is packaged in a cardboard box which can be recycled as paper.

10.3 Transport

1. Only transport the product by suitable means. Do not drop. Handle carefully.
2. After the installation dispose of transport packaging material according to relevant local or national disposal regulations / environmental protection laws.

10.4 Storage

1. Store the product free from dust and moisture in its original packaging.
2. Avoid UV rays and direct sunlight.
3. Do not exceed the maximum storage temperature (see chapter "Technical data").
4. Do not store solvents, chemicals, acids, fuels or similar fluids in the same room as GEMÜ products and their spare parts.
5. Close the compressed air connections with protection caps or sealing plugs.

10.5 Condition as supplied to customer

Condition of the product as supplied to customer: Control function 1 (normally closed).

11 Installation in piping

11.1 Preparing for installation

⚠ WARNING



The equipment is subject to pressure!

- ▶ Risk of severe injury or death
- Depressurize the plant or plant component.
- Completely drain the plant or plant component.

⚠ WARNING



Corrosive chemicals!

- ▶ Risk of caustic burns
- Wear appropriate protective gear.
- Completely drain the plant.

⚠ CAUTION



Hot plant components!

- ▶ Risk of burns
- Only work on plant that has cooled down.

⚠ CAUTION

Use as step!

- ▶ Damage to the product
- ▶ Risk of slipping-off
- Choose the installation location so that the product cannot be used as a foothold.
- Do not use the product as a step or a foothold.

⚠ CAUTION



Leakage!

- ▶ Emission of dangerous materials
- Provide for precautionary measures against exceeding the maximum permissible pressure that may be caused by pressure surges (water hammer).

NOTICE

Suitability of the product!

- ▶ The product must be appropriate for the piping system operating conditions (medium, medium concentration, temperature and pressure) and the prevailing ambient conditions.

NOTICE

Tools!

- ▶ The tools required for installation and assembly are not included in the scope of delivery.
- Use appropriate, functional and safe tools.

1. Ensure the suitability of the product for each respective use.
2. Check the technical data of the product and the materials.
3. Keep appropriate tools ready.
4. Ensure appropriate protective gear as specified in the plant operator's guidelines.
5. Observe appropriate regulations for connections.
6. Have installation work carried out by trained personnel.
7. Shut off plant or plant component.
8. Secure plant or plant component against recommissioning.
9. Depressurize the plant or plant component.
10. Completely drain the plant (or plant component) and let it cool down until the temperature is below the media vaporization temperature and scalding can be ruled out.
11. Correctly decontaminate, rinse and ventilate the plant or plant component.
12. Lay piping so that the product is protected against transverse and bending forces, and also vibrations and tension.
13. Only install the product between matching aligned pipes (see chapters below).
14. Pay attention to the installation position (see chapter "Installation position").

11.2 Installation position

You can choose the installation position of the product (see "Mechanical data", page 11).

11.3 Installation with butt weld spigots

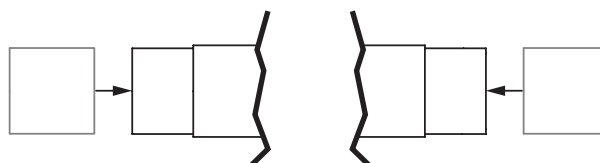


Fig. 1: Butt weld spigots

1. Carry out preparation for installation (see chapter "Preparing for installation").
2. Adhere to good welding practices!
3. Remove the actuator and diaphragm from the valve body.
4. Weld the body of the product in the piping.
5. Allow butt weld spigots to cool down.
6. Mount the actuator and diaphragm on the valve body.
7. Re-attach or reactivate all safety and protective devices.

11.4 Installation with clamp connections

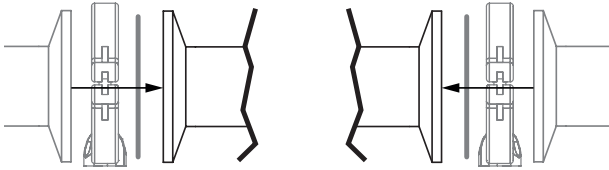


Fig. 2: Clamp connection

NOTICE

Gasket and clamp!

► The gasket and clamps for clamp connections are not included in the scope of delivery.

1. Keep ready gasket and clamp.
2. Carry out preparation for installation (see chapter "Preparing for installation").
3. Insert the corresponding gasket between the body of the product and the pipe connection.
4. Connect the gasket between the body of the product and the pipe connection using clamps.
5. Re-attach or reactivate all safety and protective devices.

11.5 Installation with threaded spigots

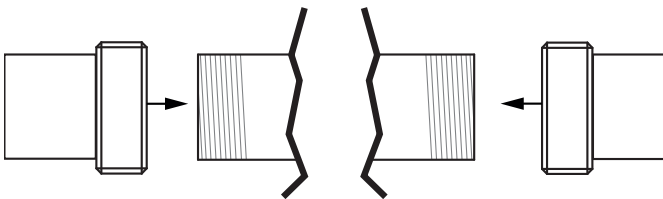


Fig. 3: Threaded spigots

NOTICE

Thread sealant!

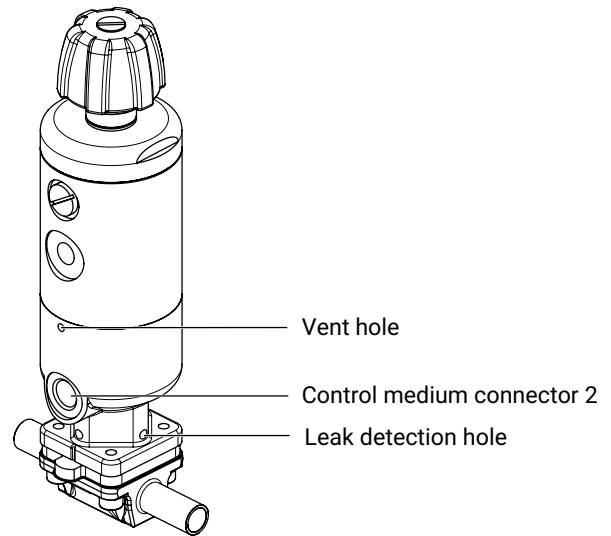
► The thread sealant is not included in the scope of delivery.
 ● Only use appropriate thread sealant.

1. Keep thread sealant ready.
2. Carry out preparations for installation (see chapter "Preparing for installation").
3. Screw the pipe into the threaded connection of the valve body in accordance with valid standards.
 ⇒ Use appropriate thread sealant.
4. Re-attach or reactivate all safety and protective devices.

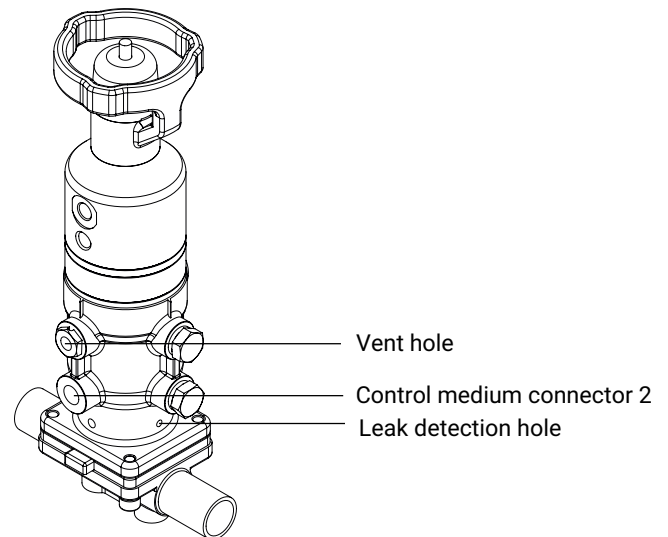
12 Pneumatic connection

12.1 Control function

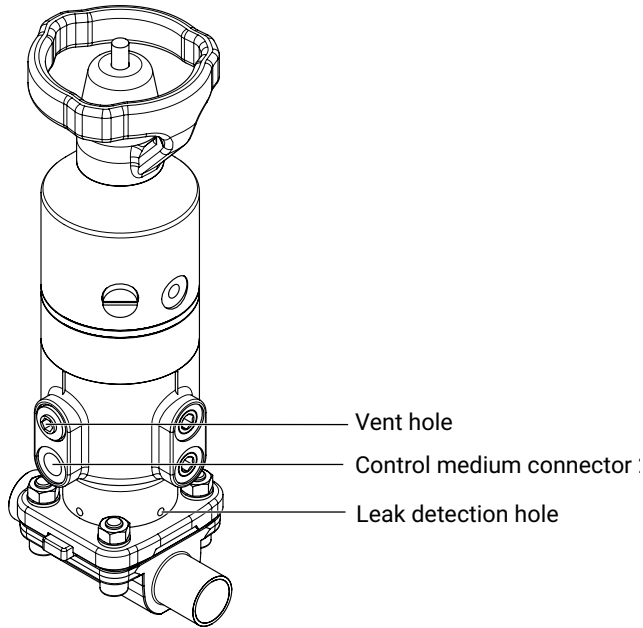
Diaphragm size 8



Diaphragm size 10



Diaphragm size 25



The product has 2 control medium connectors.

Control function	Control medium connector 2 (open)	Control medium connector 4 (close)
1 (NC)	+	-

+ = available

- = not available

Normally closed (NC):

Actuator resting position: closed by spring force. Activation of the actuator (connector 2) opens the actuator. When the actuator is vented, the actuator is closed by spring force.

12.2 Connecting the control medium

1. Use suitable connectors.
2. Connect the control medium lines tension-free and without any bends or knots.

Thread size of the control medium connectors

Diaphragm size 8–10: G 1/8

Diaphragm size 25: G 1/4

13 Stroke limiter and seal adjuster

NOTICE

- Only set the seal adjuster when the valve is completely assembled (with diaphragm and valve body) and in a cold condition.

The valves have a mechanical seal adjuster as standard to protect the sealing diaphragm against excessive closing force.

Standard setting:

The valve is sealed when the handwheel is completely closed (turned fully clockwise).

13.1 Setting the closing limit (GEMÜ 650 0TL, 0RL, 0LL)

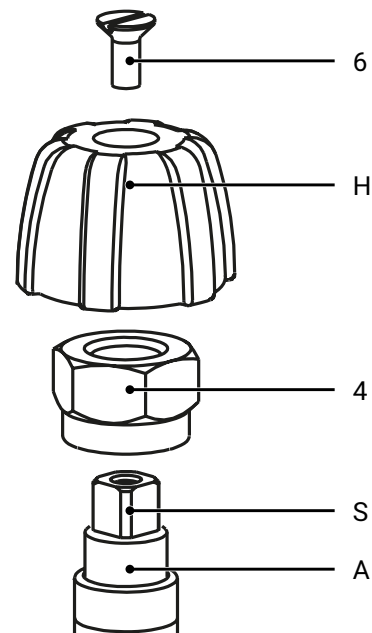


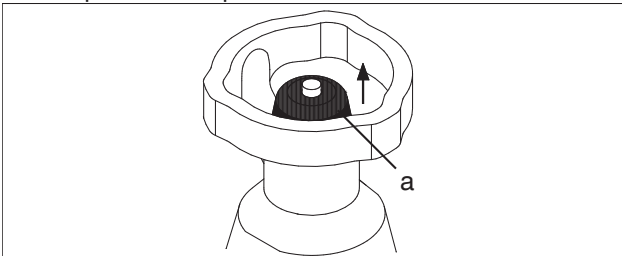
Fig. 4: Closing limiter GEMÜ 650 0TL, 0RL, 0LL

1. Open the valve approx. 50%.
2. Loosen, unscrew and remove the screw **6**.
3. Handrad **H** nach oben abziehen.
4. Loosen, unscrew and remove the adjusting ring **4**.
5. Depending on the operating conditions, regrease the actuator spindle **S**, especially a valve that is autoclaved. GEMÜ recommends the Boss-Fluorine Y 108/00 grease (99099484).
6. Place the handwheel **H** on the actuator spindle **S**.
7. Move the valve to the closed position.
8. Pull off the handwheel **H** from the actuator spindle **S**.
9. Einstellring **4** auf die Antriebsspindel **S** aufschrauben, bis die Unterseite des Einstellrings **4** bündig am Ventil-antrieb **A** anliegt.
10. Put the handwheel **H** onto the actuator spindle **S** (take care to align the hexagon of the adjusting ring **4** and the double-hexagon of the handwheel **H**).
11. Fasten the handwheel **H** with the screw **6**.

13.2 Set closing and stroke limitation (GEMÜ 650 1TL, 1RL, 1LL, 1HL, 1ML, 1SL / 650 2TL, 2RL, 2LL, 2HL, 2ML, 2SL)

Preparation for setting

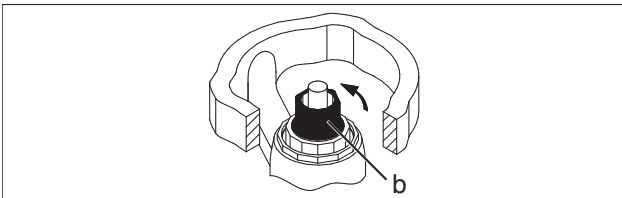
1. Pull off protective cap **a**.



2. Move the actuator out of the end positions to enable the handwheel to be rotated in both directions.

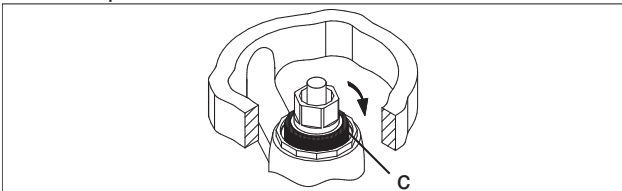
Releasing the stroke limiter

3. Turn stroke limiter **b** upwards in an anticlockwise direction until the male thread is visible.



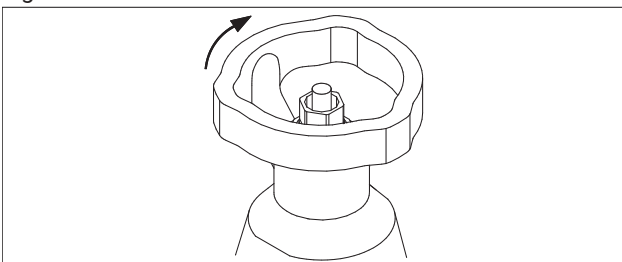
Releasing the seal adjuster

4. Turn seal adjuster **c** downwards in a clockwise direction until it stops.

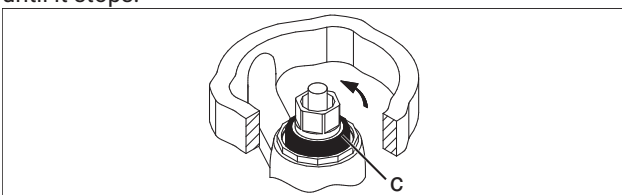


Setting the seal adjuster

5. Move the valve to the desired CLOSED position by operating the handwheel.

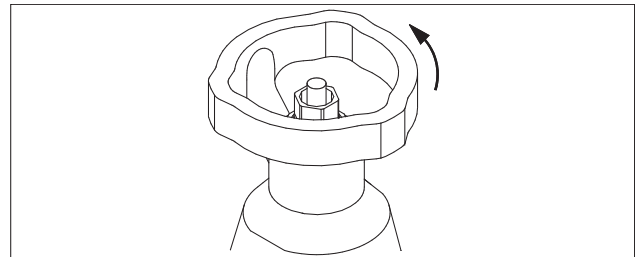


6. Turn seal adjuster **c** upwards in an anticlockwise direction until it stops.



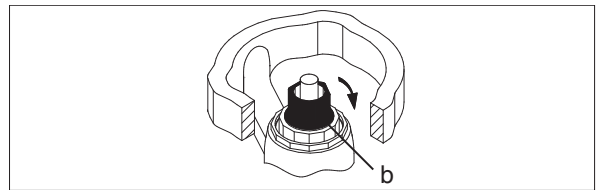
Setting the stroke limiter

7. Move the valve to the desired OPEN position by operating the handwheel.



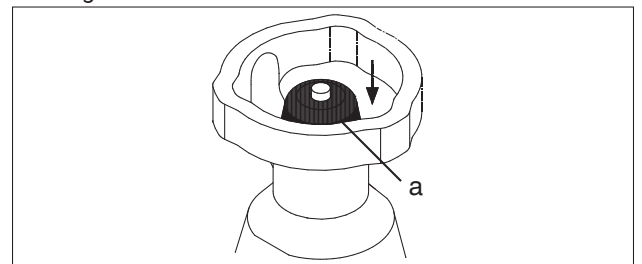
8. Turn stroke limiter **b** downwards in a clockwise direction until it stops.

⇒ The seal adjuster must not turn with it during this process.



Completing the settings

9. Put protective cap **a** in place and align the flats by a light twisting movement.



10. Press protective cap **a** down.

14 Proximity switches

NOTICE

- Only use M8x1 proximity switches which can be mounted flush.

Two proximity switches can be mounted on the GEMÜ 650TL for feedback of the closed position from the pneumatic piston 1 and handwheel 2.

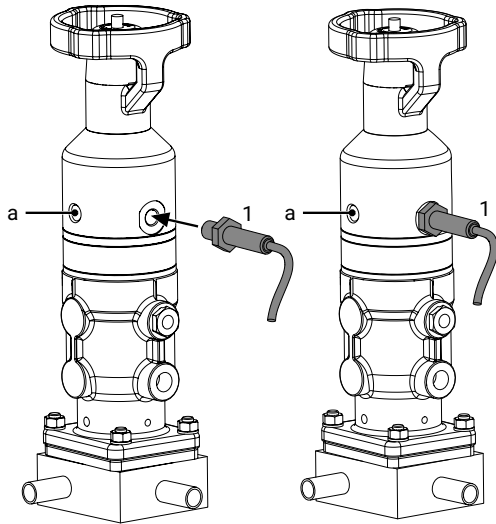


Fig. 5: Connection of pneumatic piston proximity switch

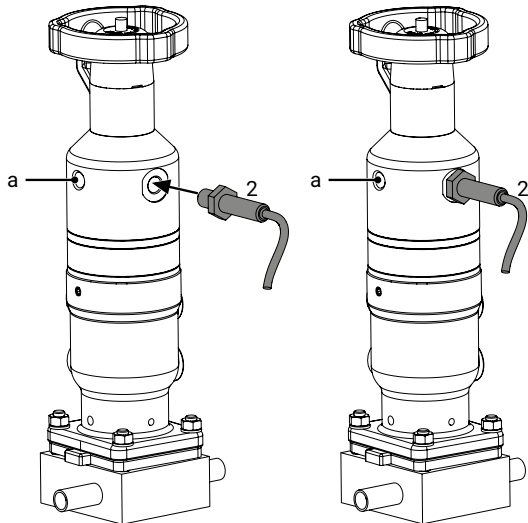


Fig. 6: Connection of handwheel proximity switch (representation turned by 180°)

NOTICE

- The upper proximity switch is for the CLOSED position of the handwheel, and the lower proximity switch is for the CLOSED position of the pneumatic piston.

14.1 Setting proximity switches

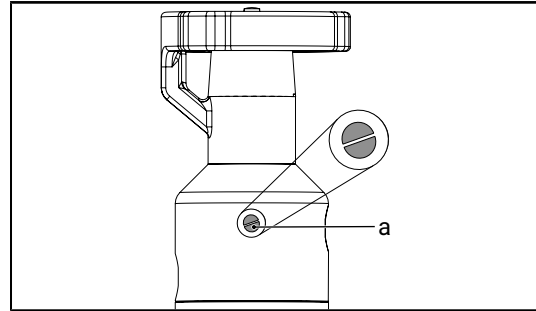
NOTICE

- The proximity switches are adjusted after complete assembly of the valve.

NOTICE

- The same procedure applies for the pneumatic piston proximity switch 1 and handwheel proximity switch 2.

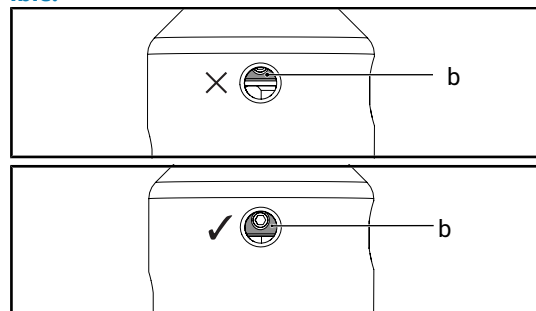
1. Remove threaded plug a from the actuator using a flat-head screwdriver.



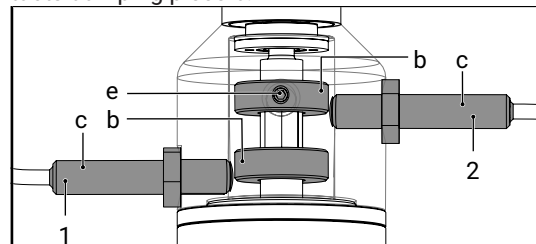
2. Move the actuator to the closed position.
3. Set (see "Setting the damping piece", page 32) damping piece b.

NOTICE!

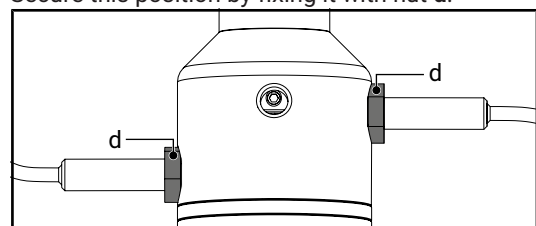
At least two-thirds of damping piece b must be visible.



4. Carefully screw in proximity switch c by hand until it contacts damping piece b.



5. Turn back proximity switch c by a 1/2 to 3/4 turn.
6. Secure this position by fixing it with nut d.



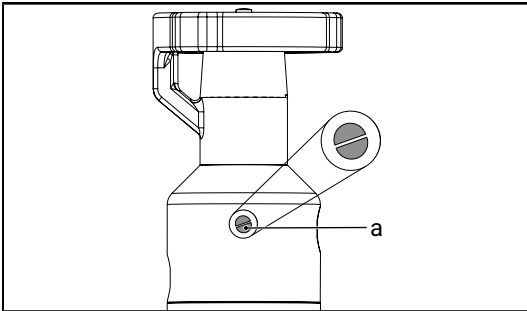
14.2 Setting the damping piece

CAUTION

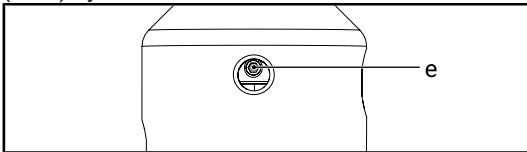
Undone grub screw.

- ▶ The grub screw and damping piece **b** may fall into the valve.
- ▶ Damage to the actuator.
- Loosen grub screw **e** only for the adjustment process.
- Do **not** pull out the Allen key during the adjustment process.
- Do **not** turn or shake the actuator further than horizontal while the grub screw **e** is loosened and the damping piece **b** is loose.

1. Remove screw plug **a** from the actuator using a flat-blade screwdriver.

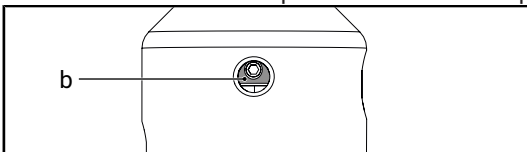


2. Loosen grub screw **e** with a hexagon socket spanner (SW2) by 1-1.5 turns.



⇒ **CAUTION! Do not unscrew grub screw **e** any more. Otherwise it might fall inside the valve.**

3. After loosening the grub screw **e**, the damping piece **b** can be moved into the correct position on the valve spindle.



4. Fix the position of the damping piece **b** with grub screw **e**.
5. Screw threaded plug **a** back in.

15 Commissioning

1. Check the tightness and the function of the product (close and reopen the product). Due to the setting behavior of elastomers, the bolts may need to be retightened following the installation and commissioning of the valve.
2. Flush the piping system of new plant and following repair work (the product must be fully open).
 - ⇒ Harmful foreign matter has been removed.
 - ⇒ The product is ready for use.
3. Commission the product.

16 Operation

Operate (see "Pneumatic connection", page 28) the product in accordance with the control function.

16.1 Control function 1

In its resting position, the product is closed by spring force.

1. Activate the actuator via control medium connector 2.
 - ⇒ The product opens.
2. Vent the actuator via control medium connector 2.
 - ⇒ The product closes.

17 Troubleshooting

Error	Possible cause	Troubleshooting
Control medium escaping from vent (GEMÜ 650 1TL/2TL) / vent hole (GEMÜ 650 0TL)	Piston faulty	Replace the actuator
Control medium escaping from leak detection hole	Spindle seal leaking	Replace actuator and check control medium for impurities
Working medium escaping from leak detection hole	Diaphragm faulty	Check diaphragm for potential damage, replace diaphragm if necessary
The product does not open or does not open fully	Control pressure too low (for control function NC)	Operate the product with the control pressure specified in the datasheet
	Pilot valve faulty	Check and replace pilot valve
	Actuator defective	Replace the actuator
	Control medium not connected	Connect control medium
	Shut-off diaphragm incorrectly mounted	Remove the actuator, check the diaphragm mounting, replace the shut-off diaphragm if necessary
	Stroke limiter is incorrectly set (only for GEMÜ 650 1TL and 650 2TL)	Reset stroke limiter
	Handwheel is in the closed position	Move the handwheel to the open position
The product is leaking downstream (does not close or does not close fully)	Operating pressure too high	Operate the product with operating pressure specified in datasheet
	Foreign matter between shut-off diaphragm and valve body	Remove the actuator, remove foreign matter, check diaphragm and valve body for potential damage, replace damaged parts if necessary
	Valve body leaks or is damaged	Check valve body for potential damage, replace valve body if necessary.
	Shut-off diaphragm faulty	Check shut-off diaphragm for potential damage, replace the shut off diaphragm if necessary
	Actuator spring faulty (for control function NC)	Replace actuator
	Seal adjuster is incorrectly set (only effective when control medium is applied to the actuator)	Reset seal adjuster
	Handwheel open when control medium is applied	Move the handwheel to the closed position
The product is leaking between actuator and valve body	Shut-off diaphragm incorrectly mounted	Remove the actuator, check the diaphragm mounting, replace the shut-off diaphragm if necessary
	Bolting between valve body and actuator loose	Tighten bolting between valve body and actuator
	Shut-off diaphragm faulty	Check shut-off diaphragm for potential damage, replace the shut-off diaphragm if necessary
	Actuator/valve body damaged	Replace actuator/valve body
Connection between valve body and piping leaking	Incorrect installation	Check installation of valve body in piping
	Threaded connections / unions loose	Tighten threaded connections / unions
	Sealing material faulty	Replace sealing material
Valve body leaking	Valve body leaking or corroded	Check valve body for damage, replace valve body if necessary

Error	Possible cause	Troubleshooting
Handwheel cannot be turned	Handwheel faulty	Replace the handwheel for diaphragm size 8. Replace the actuator for diaphragm size 10 and 25.
	Stroke limiter and seal adjuster incorrectly set	Release and reset stroke limiter and seal adjuster
Proximity switches also respond in the open position	Use of wrong proximity switches	Only use M8x1 proximity switches which can be mounted flush
	Damping piece incorrectly adjusted	Reset damping piece

18 Inspection and maintenance

⚠ WARNING



The equipment is subject to pressure!

- ▶ Risk of severe injury or death
- Depressurize the plant or plant component.
- Completely drain the plant or plant component.

⚠ CAUTION



Hot plant components!

- ▶ Risk of burns
- Only work on plant that has cooled down.

⚠ CAUTION

- Servicing and maintenance work must only be performed by trained personnel.
- Do not extend hand lever. GEMÜ shall assume no liability for damages caused by improper handling or third-party actions.
- In case of doubt, contact GEMÜ prior to commissioning.

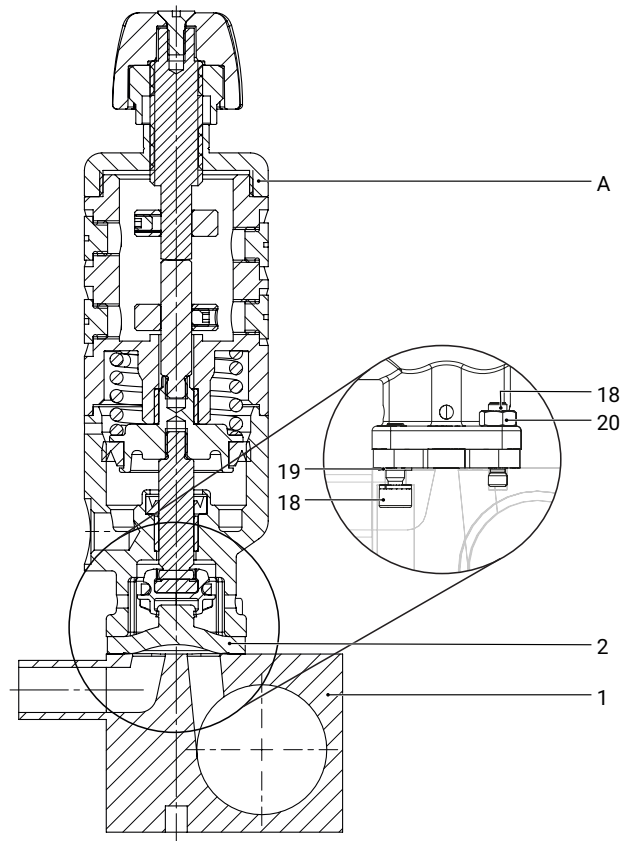
The operator must carry out regular visual examination of the GEMÜ products dependent on the operating conditions and the potential danger in order to prevent leakage and damage.

The product also must be disassembled and checked for wear in the corresponding intervals.

1. Have servicing and maintenance work performed by trained personnel.
2. Wear appropriate protective gear as specified in plant operator's guidelines.
3. Shut off plant or plant component.
4. Secure the plant or plant component against recommissioning.
5. Depressurize the plant or plant component.
6. Actuate GEMÜ products which are always in the same position four times a year.

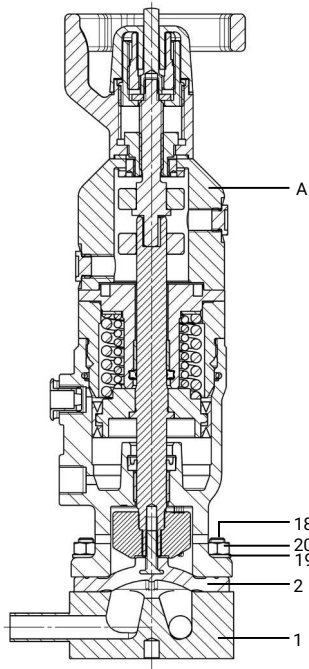
18.1 Spare parts

18.1.1 Spare parts 0TL



Item	Name	Order designation
1	Body	K600
2	Diaphragm	600...M
18, 19, 20	Mounting set (screws, washers, nuts)	650 S30
A	Actuator	9650TL

18.1.2 Spare parts 1TL; 2TL



Item	Name	Order designation
A	Actuator	9650TL
2	Diaphragm	600...M
1	Body	K600
18, 19	Mounting set (screws, washers, nuts)	650 S30

18.2 Removing the actuator

1. Move the actuator **A** to the open position.
2. Loosen the fastening elements between actuator **A** and valve body **1** diagonally and remove them.
3. Lift actuator **A** off valve body **1**.
4. Move the actuator **A** to the closed position.
5. Clean all parts of contamination (do not damage parts during cleaning).
6. Check parts for potential damage, replace if necessary (only use genuine parts from GEMÜ).

18.3 Removing the diaphragm

1. Remove actuator **A** (see chapter "Removing the actuator").
2. Unscrew the diaphragm (diaphragm size 10 to 100) or pull it out (diaphragm size 8).
3. Clean all parts of contamination (do not damage parts during cleaning).
4. Check parts for potential damage, replace if necessary (only use genuine parts from GEMÜ).

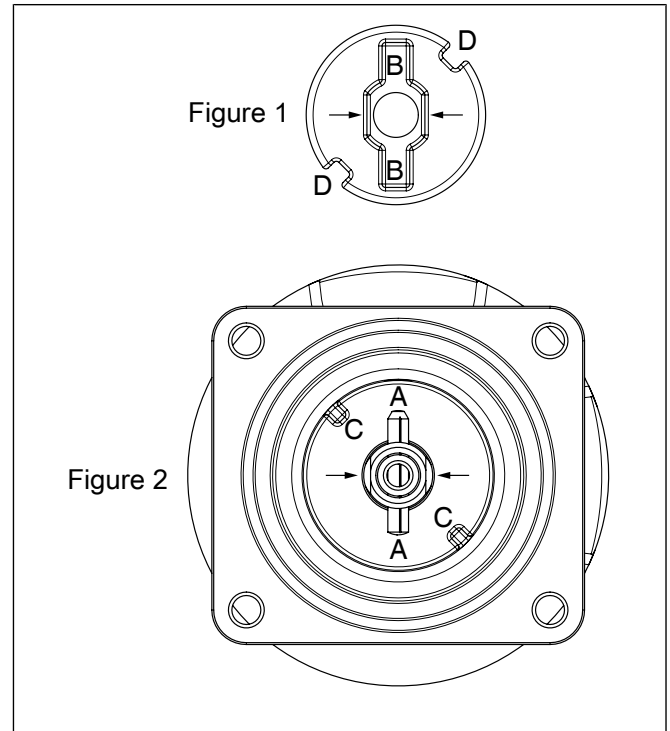
18.4 Mounting the compressor

NOTICE

Compressor mounting

- ▶ Compressor mounting only concerns diaphragm sizes 10 and 25. With diaphragm size 8, the compressor is fixed to the spindle.
- If the compressor was also removed when the diaphragm was removed, it must be remounted before the new diaphragm is mounted.

18.4.1 Mounting the compressor (diaphragm size 10)

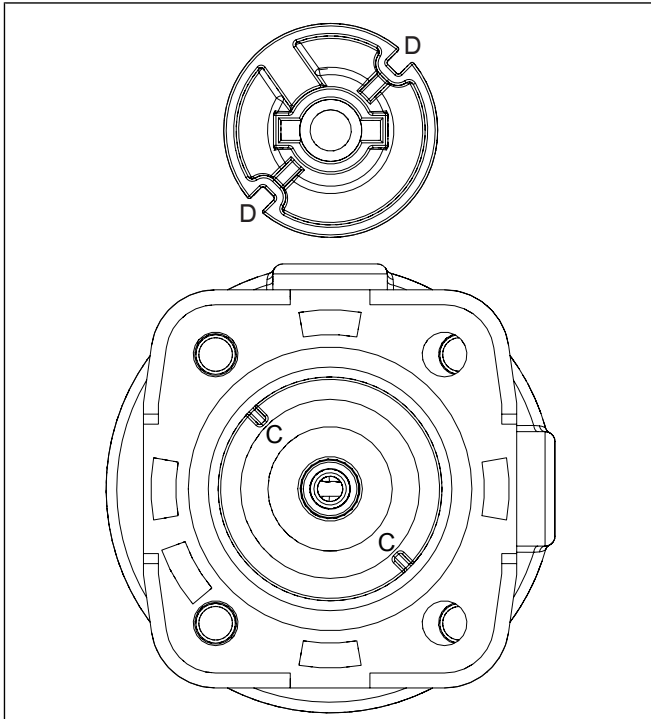


Anti-twist system of the spindle at the compressor

A double flat (arrows figure 2) is fitted at the end of the actuator spindle to protect the actuator spindle against twisting. When mounting the compressor, the double flat must be in correct alignment with the recess of the compressor back (arrows figure 1). If the actuator spindle is not in the correct position, it must be turned to the correct position. The position of **A** is offset by 45° to the position of **C**.

1. Place the compressor loosely on the actuator spindle.
 2. Insert the recesses **D** into the guides **C** and the double flats into the recess of the compressor back **B**.
- ⇒ The compressor must be able to be moved freely between the guides.

18.4.2 Mounting the compressor (diaphragm size 25)



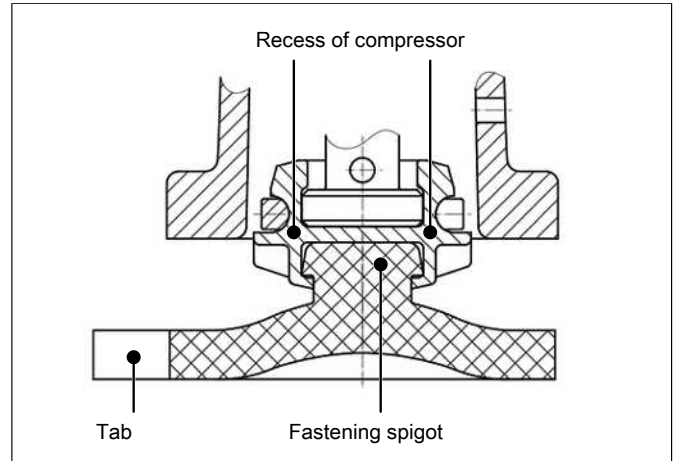
1. Place the compressor loosely on the actuator spindle.
 2. Fit recesses **D** into guides **C**.
- ⇒ It must be possible to move the compressor freely between the guides.

18.5 Mounting the diaphragm

18.5.1 Mounting the concave diaphragm

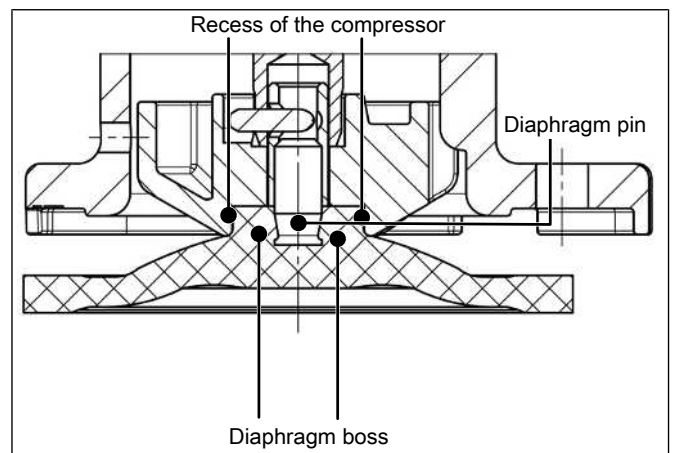
18.5.1.1 Diaphragm size 8 (push-fit diaphragm)

Diaphragm size 8 Push-fit diaphragm



1. Move the actuator **A** to the closed position.
2. Mount the compressor (see "Mounting the compressor").
3. Check if the compressor is fitted in the guides.
4. Place the diaphragm with the rubber pin in an inclined position at the recess of the compressor.
 - ⇒ Do not use greases or lubricants.
5. Manually screw/press the new diaphragm into the compressor.
6. Align the weir of compressor and diaphragm in parallel.
7. Check the technical condition and function of the valve prior to commissioning and during the total term of use.
8. Carry out checks regularly and determine the test intervals in compliance with the conditions of use and/or the regulatory codes and provisions applicable for this application.

18.5.1.2 Diaphragm size 10 (threaded pin type diaphragm)



NOTICE**Diaphragm is not screwed in far enough.**

- ▶ The closing force is transmitted directly onto the diaphragm pin and not via the compressor.
- ▶ Damage and early failure of the diaphragm.
- ▶ Leakage of the valve.
- Remove the diaphragm.
- Check the valve and diaphragm.
- Remount the diaphragm.

NOTICE**Diaphragm is screwed in too far.**

- ▶ Seal at the valve seat is not faultless.
- ▶ Function of the valve is no longer ensured.
- Remove the diaphragm.
- Check the valve and diaphragm.
- Remount the diaphragm.

1. Move the actuator **A** to the closed position.
2. Mount the compressor (see "Mounting the compressor").
3. Ensure that the anti-twist system is engaged.
4. Check if the compressor is fitted in the guides.
5. Manually screw new diaphragm tightly into the compressor.
6. Check if the diaphragm boss fits closely in the recess of the compressor.
7. If it is difficult to screw it in, check the thread and replace damaged parts.
8. When definitive resistance is felt, turn back the diaphragm until its bolt holes are in correct alignment with the bolt holes of the actuator.
9. Check the technical condition and function of the valve prior to commissioning and during the total term of use.
10. Carry out checks regularly and determine the test intervals in compliance with the conditions of use and/or the regulatory codes and provisions applicable for this application.

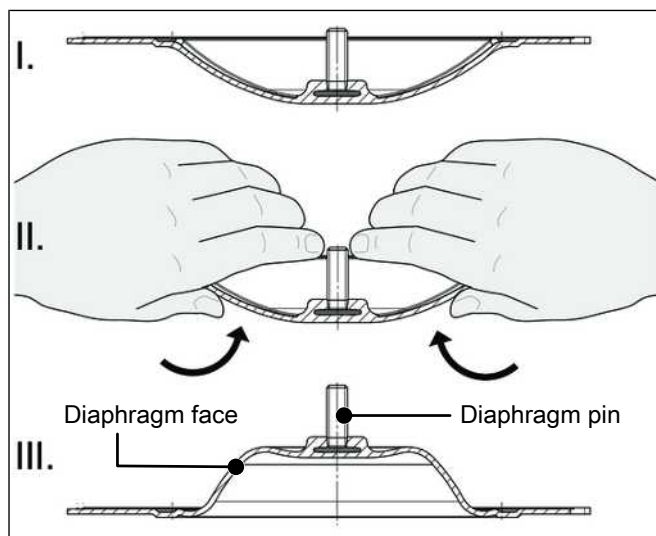
18.5.2 Mounting the convex diaphragm

Fig. 7: Inverting the diaphragm face

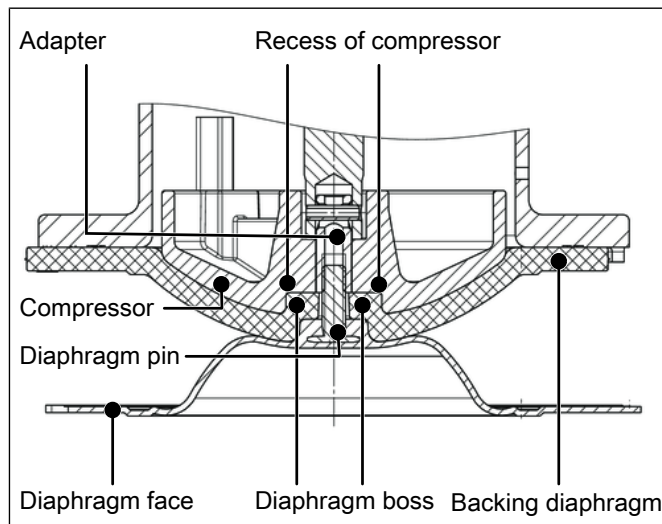


Fig. 8: Screwing in the diaphragm face

NOTICE**Diaphragm is not screwed in far enough.**

- ▶ The closing force is transmitted directly onto the diaphragm pin and not via the compressor.
- ▶ Damage and early failure of the diaphragm.
- ▶ Leakage of the valve.
- Remove the diaphragm.
- Check the valve and diaphragm.
- Remount the diaphragm.

NOTICE**Diaphragm is screwed in too far.**

- ▶ Seal at the valve seat is not faultless.
- ▶ Function of the valve is no longer ensured.
- Remove the diaphragm.
- Check the valve and diaphragm.
- Remount the diaphragm.

1. Move the actuator **A** to the closed position.
2. Mount the compressor (see "Mounting the compressor").
3. Check if the compressor is fitted in the guides.
4. Invert the new diaphragm face manually (use a clean, padded mat with larger nominal sizes).
5. Position the new backing diaphragm onto the compressor.
6. Position the diaphragm face onto the backing diaphragm.
7. Screw diaphragm face tightly into the compressor manually.
 - ⇒ The diaphragm boss must fit closely in the recess of the compressor.
8. If it is difficult to screw it in, check the thread and replace damaged parts.
9. When definitive resistance is felt, turn back the diaphragm until its bolt holes are in correct alignment with the bolt holes of the actuator.

10. Press the diaphragm face tightly onto the backing diaphragm manually so that it returns to its original shape and fits closely on the backing diaphragm.
11. Align the weir of compressor and diaphragm in parallel.
12. Check the technical condition and function of the valve prior to commissioning and during the total term of use.
13. Carry out checks regularly and determine the test intervals in compliance with the conditions of use and/or the regulatory codes and provisions applicable for this application.

18.6 Mounting the actuator

NOTICE

Diaphragms set in the course of time.

- After valve disassembly / assembly check that the fastening elements on the body are tight and retighten as necessary (at the very latest after the first sterilization process).
1. Move the actuator **A** to the open position.
 2. Position actuator **A** with the mounted diaphragm on the valve body.
 - ⇒ Diaphragm size 8: Take care to align the compressor weir and valve body weir.
 3. Tighten fastening elements by hand (hand tight only) (fastening elements may vary dependent on diaphragm size and / or valve body version).

NOTICE

- ▶ GEMÜ recommends using new screws that are coated accordingly to prevent galling.
4. Move the actuator **A** to the closed position.
 5. Fully tighten fastening elements diagonally.
 6. Ensure even compression of the diaphragm (approx. 10 to 15%).
 - ⇒ Even compression is detected by an even outer bulge.
 7. **Please note:** For a code 5M diaphragm (convex diaphragm), the PTFE diaphragm face and the EPDM backing diaphragm must be positioned level with and parallel to the valve body.
 8. With the valve fully assembled, check the function and tightness.

19 Disposal

1. Pay attention to adhered residual material and gas diffusion from penetrated media.
2. Dispose of all parts in accordance with the disposal regulations/environmental protection laws.

20 Returns

Legal regulations for the protection of the environment and personnel require that the completed and signed return delivery note is included with the dispatch documents. Returned goods can be processed only when this note is completed. If no return delivery note is included with the product, GEMÜ cannot process credits or repair work but will dispose of the goods at the operator's expense.

1. Clean the product.
2. Request a return delivery note from GEMÜ.
3. Complete the return delivery note.
4. Send the product with a completed return delivery note to GEMÜ.

21 EU Declaration of Incorporation according to the EC Machinery Directive 2006/42/EC, Annex II B



EU Declaration of Incorporation

according to the EC Machinery Directive 2006/42/EC, Annex II B

We, the company GEMÜ Gebr. Müller Apparatebau GmbH & Co. KG
Fritz-Müller-Strasse 6-8
74653 Ingelfingen-Criesbach, Germany

hereby declare under our sole responsibility that the below-mentioned product complies with the relevant essential health and safety requirements in accordance with Annex I of the above-mentioned Directive.

Product: GEMÜ 650TL
Product name: Manually operated diaphragm valve
The following essential health and safety requirements of the EC Machinery Directive 2006/42/EC, Annex I have been applied or adhered to: 1.1.3.; 1.1.5.; 1.3.2.; 1.3.3.; 1.3.4.; 1.3.7.; 1.5.13.; 1.5.3.; 1.5.4.; 1.5.5.; 1.5.8.; 1.5.9.; 1.6.1.; 1.7.1.; 1.7.2.; 1.7.3.; 1.7.4.; 1.7.4.1.; 1.7.4.2.; 1.7.4.3.
The following harmonized standards (or parts thereof) have been applied: EN ISO 12100:2010

We also declare that the specific technical documents have been created in accordance with part B of Annex VII.

The manufacturer undertakes to transmit relevant technical documents on the partly completed machinery to the national authorities in response to a reasoned request. This communication takes place electronically.

This does not affect the industrial property rights.

The partly completed machinery may be commissioned only if it has been determined, if necessary, that the machinery into which the partly completed machinery is to be installed meets the provisions of the Machinery Directive 2006/42/EC.

M. Barghoorn
Head of Global Technics
Ingelfingen, 19/12/2023

22 Manufacturer's declaration according to the Pressure Equipment Directive 2014/68/EU



Manufacturer's declaration

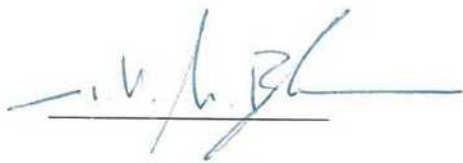
according to the Pressure Equipment Directive 2014/68/EU

We, the company GEMÜ Gebr. Müller Apparatebau GmbH & Co. KG
Fritz-Müller-Strasse 6-8
74653 Ingelfingen-Criesbach, Germany

declare that the below-mentioned product is designed and manufactured in compliance with sound engineering practice according to Article 4, Paragraph 3 of the Pressure Equipment Directive 2014/68/EU.

Product: GEMÜ 650TL
Product name: Manually operated diaphragm valve

The product has been developed and produced according to GEMÜ's in-house process instructions and standards of quality which comply with the requirements of ISO 9001 and ISO 14001. According to Article 4, Paragraph 3 of the Pressure Equipment Directive 2014/68/EU, this product must not be identified by a CE-marking.



M. Barghoorn
Head of Global Technics

Ingelfingen, 19/12/2023



GEMÜ Gebr. Müller Apparatebau GmbH & Co. KG
Gert-Müller-Platz 1, 74635 Kupferzell, Germany
Phone +49 (0) 7940 1230 · info@gemue.de
www.gemu-group.com

Subject to alteration

04.2026 | 88899546