

Construction

The iComLine C50, C51 and C57 HPW ultra pure 2/2-way plastic diaphragm globe valves have a PFA or PTFE body. All medium wetted parts are made of PFA or PTFE. The external operator parts are made of PVDF. The union nuts are available in PVDF, PFA and C-PFA. An optical position indicator is integrated as standard. For type C50 a stroke limiter is available as standard or as an option depending on the operator size. In addition to 2/2-way valve bodies customised multi-port valve block solutions can be produced (see last page).

Features

- Globe valve, small footprint
- All wetted parts PFA or PTFE
- PTFE diaphragm (one-piece, no diaphragm backing material)
- 5 million cycle duties qualified
- Standard connections and accessories
- Minimal deadleg
- Fast rinsing, minimal contamination
- High temperature application limit (High temperature version up to 200 °C)
- Good Kv value
- Cleanroom production (HP version), complies with SEMI F 57
- Version with PTFE coated screws and compression springs

Advantages

- Compact design, low space requirement, good drainability
- Universal chemical resistance, wide range of applications
- Long service life, low operating costs
- Flexible and suitable for versatile use, also for high temperature applications
- Low pressure loss, low operating costs
- Size and cost reduction due to wide range of operator and connection size versions
- Minimal contamination, suitable for high purity media

Sectional drawing

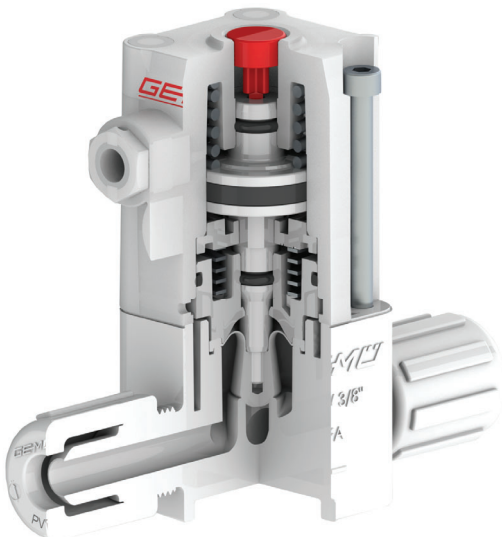

C50 HPW



C51 HPW



C57 HPW



General technical data

Working medium

Corrosive, inert, gaseous and liquid media - particularly high purity media - which have no negative impact on the physical and chemical properties of the body and diaphragm material.

Flow direction

It is indicated by an arrow on the valve body

Operating pressure

Max. 6.0 bar applied upstream

Vacuum 400 mbar/abs*

* The life expectancy of the valve may be affected if exposed to a greater vacuum.

Operating temperature

See temperature/pressure diagram

Ambient temperature

Max. 60 °C (130 °F)

Materials

Media wetted parts (body)	PFA and PTFE
Diaphragm	PTFE
External operator parts	PVDF

Correlation operator/seat size/version

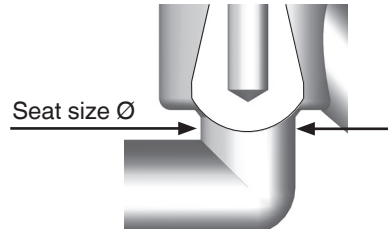

Operator size	0	1	2	3	4
Version	0A1	1A1	2A1	3A1	4A1
Ø seat size [mm]	2.48	6.38	9.55	15.80	22.25

Temperature / pressure diagram

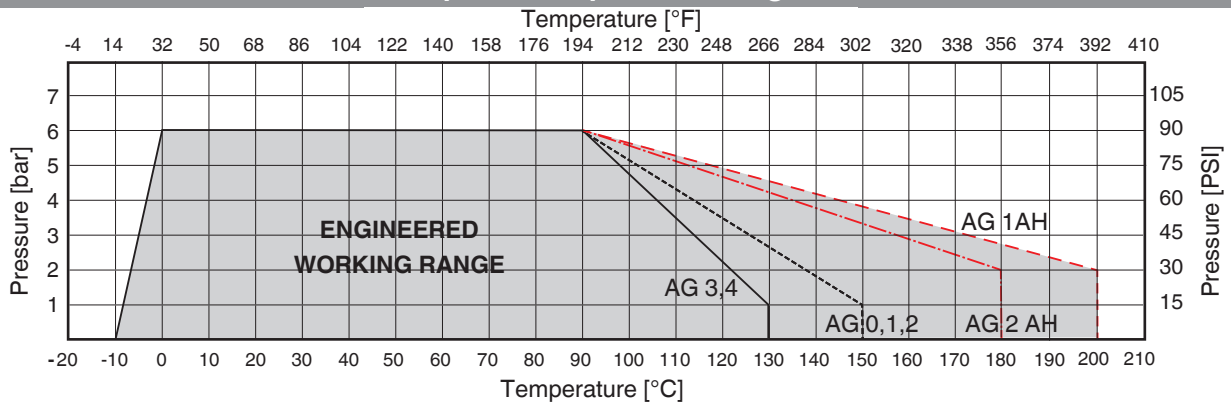

AG = Operator size

Information on the use of the temperature / pressure diagram

The temperature / pressure diagram is only an aid. The data refers to water as a working medium.

A change of operating conditions or other media may result in deviations. In case of doubt it is advisable to test the behavior of the material under the definitive operating conditions by means of a test installation.

Temperatures below 0 °C may influence negatively the operating speed.

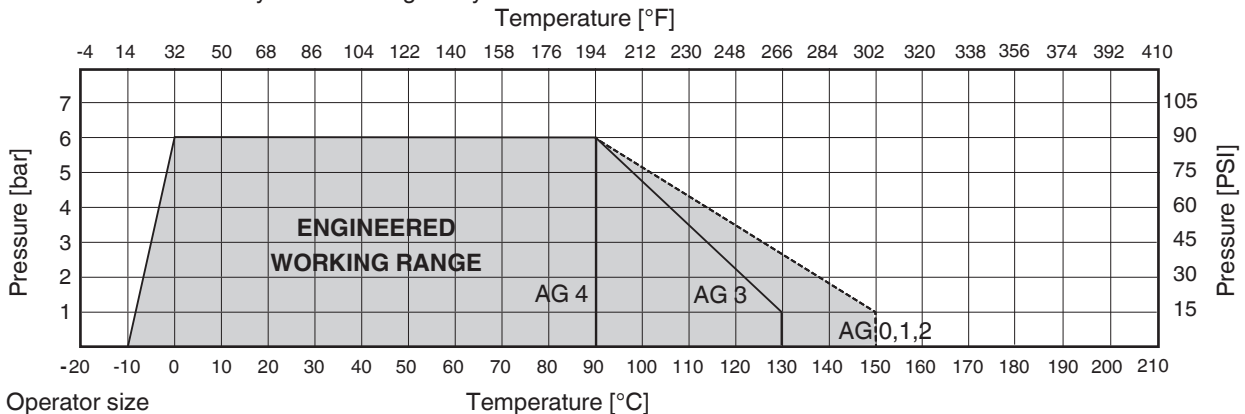

AG = Operator size

Pressure/temperature diagram applies to valve bodies made of PTFE (material code SP).

Max. Kv / Cv values - 2/2-way valves

Connection				Size			Max. operating pressure	Kv value	Cv value	Weight [g]		
Size		Connection	Code	Code intern.	DN	Operator version	[bar/PSI]	[l/min]	[US gal/min]	C50	C51	C57
1/4"	Tube	Flare	73, 75, 77	4	4	0A1	6.0 / 90	2.0	0.14	58	60	-
	Tube	Pillar Super 300 Type	79	4	4	0A1	6.0 / 90	2.0	0.14	58	60	-
	Tube	Nexus Connect®	NX	4	4	0A1	6.0 / 90	2.0	0.14	58	60	-
	Tube	PrimeLock	PL	4	4	0A1	6.0 / 90	2.0	0.14	62	64	-
	Tube	Flare	73, 75, 77	4	4	1A1	6.0 / 90	3.3	0.23	227	224	226
	Tube	Pillar Super 300 Type	79	4	4	1A1	6.0 / 90	4.0	0.28	251	243	243
	Tube	Nexus Connect®	NX	4	4	1A1	6.0 / 90	4.0	0.28	251	243	243
	Tube	PrimeLock	PL	4	4	1A1	6.0 / 90	3.3	0.23	227	224	226
3/8"	Tube	Flare	73, 75, 77	6	6	1A1	6.0 / 90	11.0	0.77	231	229	231
	Tube	Pillar Super 300 Type	79	6	6	1A1	6.0 / 90	11.7	0.82	263	255	255
	Tube	Nexus Connect®	NX	6	6	1A1	6.0 / 90	11.7	0.82	263	255	255
	Tube	PrimeLock	PL	6	6	1A1	6.0 / 90	11.0	0.77	231	229	231
1/2"	Tube	Flare	73, 75, 77	8	10	1A1	6.0 / 90	11.3	0.79	236	234	236
	Tube	PrimeLock	PL	8	10	1A1	6.0 / 90	11.3	0.79	257	254	256
	Tube	Flare	73, 75, 77	8	10	2A1	6.0 / 90	25.0	1.75	462	509	487
	Tube	Pillar Super 300 Type	79	8	10	2A1	6.0 / 90	23.7	1.66	513	578	564
	Tube	Nexus Connect®	NX	8	10	2A1	6.0 / 90	23.7	1.66	513	578	564
	Tube	PrimeLock	PL	8	10	2A1	6.0 / 90	25.0	1.75	462	509	487
3/4"	Tube	Flare	73, 75, 77	12	15	2A1	6.0 / 90	25.4	1.78	473	520	498
	Tube	PrimeLock	PL	12	15	2A1	6.0 / 90	25.4	1.78	521	568	545
	Tube	Flare	73, 75, 77	12	15	3A1	6.0 / 90	63.6	4.45	765	-	772
	Tube	Pillar Super 300 Type	79	12	15	3A1	6.0 / 90	75.0	5.25	908	-	950
	Tube	Nexus Connect®	NX	12	15	3A1	6.0 / 90	75.0	5.25	908	-	950
	Tube	PrimeLock	PL	12	15	3A1	6.0 / 90	63.6	4.45	765	-	772
1"	Tube	Flare	73, 75, 77	16	20	3A1	6.0 / 90	64.2	4.49	817	-	774
	Tube	PrimeLock	PL	16	20	3A1	6.0 / 90	64.2	4.49	867	-	874
	Tube	Flare	73, 75, 77	16	20	4A1	6.0 / 90	137.5	9.63	1930	-	1480
	Tube	Pillar Super 300 Type	79	16	20	4A1	6.0 / 90	137.0	9.59	2450	-	2000
	Tube	Nexus Connect®	NX	16	20	4A1	6.0 / 90	137.0	9.59	2450	-	2000
	Tube	PrimeLock	PL	16	20	4A1	6.0 / 90	137.5	9.63	1930	-	1480
1 1/4"	Tube	Flare	73, 75, 77	20	25	4A1	6.0 / 90	139.0	9.73	1973	-	1523
	Tube	Pillar Super 300 Type	79	20	25	4A1	6.0 / 90	145.0	10.15	2650	-	2200
	Tube	Nexus Connect®	NX	20	25	4A1	6.0 / 90	145.0	10.15	2650	-	2200
	Tube	PrimeLock	PL	20	25	4A1	6.0 / 90	139.0	9.73	1973	-	1523

Kv / Cv values GEMÜ C50 (NC) depending on control pressure

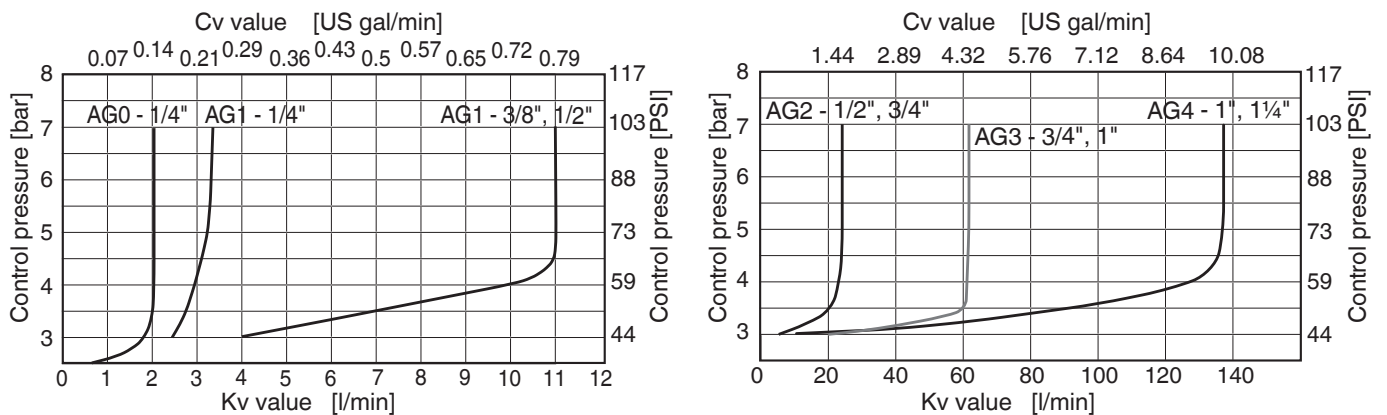

AG = Operator size

Kv values determined acc. to DIN EN 60534, inlet pressure 6 bar, Δp 1 bar, valve body material PFA and PTFE with PTFE diaphragm.

Kv / Cv values GEMÜ C57 dependent on number of handwheel turns

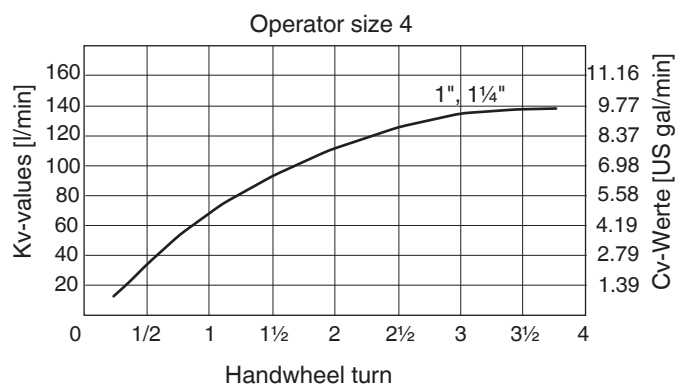
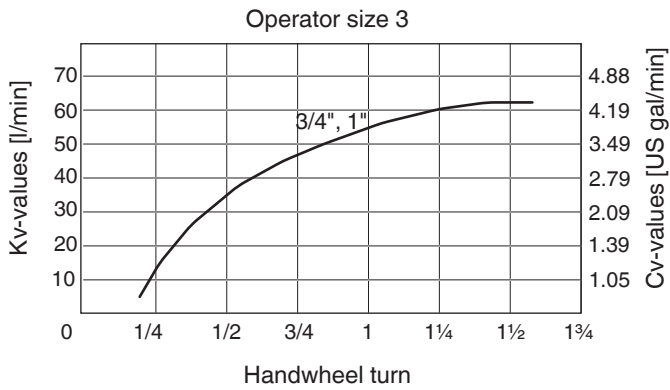
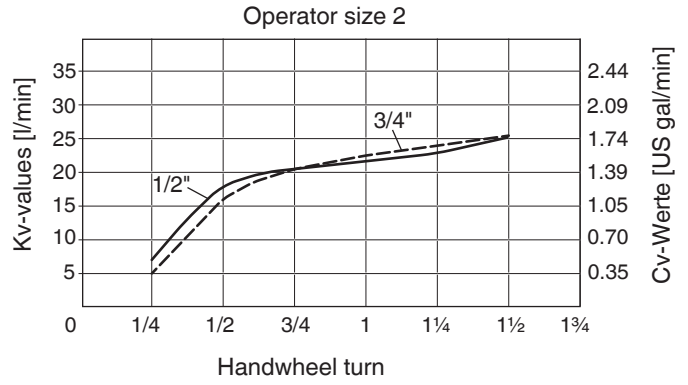
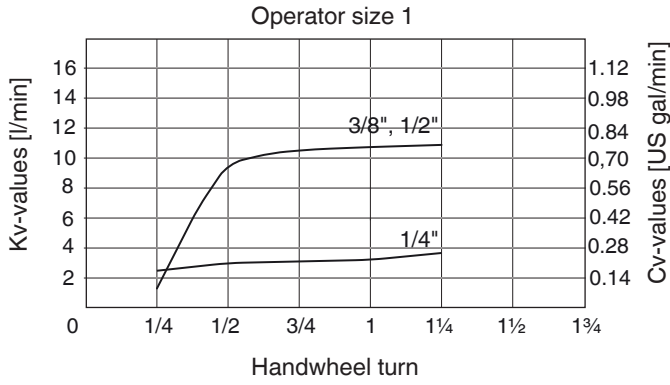

Technical data - GEMÜ C50 HPW

Filling volume [cm ³]			
Operator size	Control function		Filling volume
0	1	Normally closed (NC)	0,67
	2	Normally open (NO)	0,88
1	1	Normally closed (NC)	6,27
	2	Normally open (NO)	4,38
2	1	Normally closed (NC)	22,13
	2	Normally open (NO)	25,32
3	1	Normally closed (NC)	33,47
	2	Normally open (NO)	48,20
4	1	Normally closed (NC)	95,33
	2	Normally open (NO)	118,41

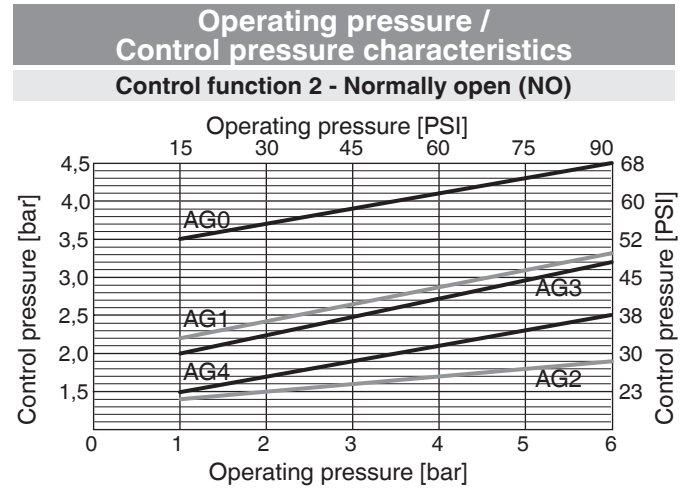

Control pressure

Normally closed (NC), (Operator size 0)	5 - 7 bar
Normally closed (NC), (Operator size 1 - 4)	4 - 7 bar
Normally open (NO), (Operator size 0)	max. 7 bar*
Normally open (NO), (Operator size 1 - 4)	max. 4 bar*

* For required control pressure depending on operating pressure see diagram.

Control medium connection

Connection size (Operator size 0)	M5
Connection size (Operator size 1 - 4)	G 1/8

Test specifications / Production tests

Qualification tests

Valve	Component	Test conditions	Required criteria
Bursting pressure at room temperature			
C50, C51, C57	Valve body	Maintain specified water pressure for 1 hour. If OK, determine bursting pressure.	Bursting pressure = 4.2 x PN max. (25.2 bar)
	Pneumatic actuator	Maintain control pressure for 10 minutes. Pressure ratings: 10, 14, 17, 19 bar	Bursting pressure $\geq 2 \times$ PST max. (> 12 bar)
Service life at room temperature*			
C50	Valve assembly	Valves switched at room temperature. No medium, no pressure	No leakage externally or via the seat for up to 5 million switching cycles
C51,C57	Valve assembly	Valves switched at room temperature. No medium, no pressure	No leakage externally or via the seat for up to 5000 switching cycles
Hot oil test*			
C50 High temperature	Valve assembly	AG 1 switched at 200°C, AG 2 switched at 180°C hot oil	No leakage externally or via the seat for up to 2 million switching cycles
Hot water test			
C50	Valve assembly	Valves switched at 130 °C/150 °C hot water	No leakage externally or via the seat for up to one week per temperature level
C51,C57	Valve assembly	Valves not switching at 130 °C/150 °C hot water, 100 % open	
Temperature change test			
C50	Valve assembly	Valves switched at -10 °C/+60 °C in temperature changes. No medium, no pressure. Cycle time 4 hours.	No leakage externally or via the seat after 42 temperature change cycles.
C51,C57	Valve assembly	Valves not switching at -10 °C/+60 °C in tempera- ture changes. No medium, no pressure. Cycle time 4 hours.	
Vacuum test			
C50	Valve assembly (NO)	Up to 200,000 switching exchange at max. con- trol pressure, then 1 week closed	Valve fully opens at 400 mbar / abs.

All final tests were carried out with a test pressure at room temperature.

Testing pressure: seat leak tightness: $PS \times 1.1 = (6.6 \text{ bar})$, external leak tightness: $PS \times 1.5 = (9 \text{ bar})$

	Test conditions	Test duration	Required criteria
External leak tightness	Testing pressure 7.4 bar	60 s	Pressure drop < 0.1 bar
Seat leak tightness	Testing pressure 6.6 bar	60 s	Pressure drop < 0.1 bar
Actuator leak tightness	Testing pressure 7.4 bar	5 s	Pressure drop < 40 Pa/sec.

Surface roughness

Description of components	Specified acc. to SEMI F57-0301 spec.	GEMÜ measurement results
Injection moulded PFA valve body	$\leq 0.35 \mu\text{m}$	0.05 μm
Machined PTFE special blocks	$\leq 0.62 \mu\text{m}$	0.48 μm

Order data

Type	Code
Valve with pneumatic operator	C50
Manually operated - Toggle (Quarter Turn)	C51
Manually operated - Handwheel (Multi Turn)	C57

Nominal size	Code
1/4" DN 4 (Operator size 0 only C50/C51)	4
3/8" DN 6	6
1/2" DN 10	8
3/4" DN 15 (only C50/C57)	12
1" DN 20 (only C50/C57)	16
1 1/4" DN 25 (only C50/C57)	20

Body configuration	Code
2/2-way body	D

Valve body connection	Code
Flare connection with PVDF union nut	75
Flare connection with PFA union nut	77
Flare connection with C-PFA union nut	73
PrimeLock with PFA union nut	PL
Pillar Super 300 type with PFA union nut	79
Nexus Connect® with PFA union nut	NX

Valve body material	Code
PFA, perfluoroalkoxy (only Flare and PrimeLock connection)	30
PTFE, polytetrafluoroethylene (only Pillar connection and Nexus Connect® or high temperature version)	26
PTFE polytetrafluoroethylene (only Nexus Connect®)	SP

Seal material	Code
PTFE	5

Control function	Code
Manually operated (only C51/C57)	0
Normally closed (only C50)	1
Normally open (only C50)	2

Operator version	Code
Standard version	
Operator size 0, seat Ø 2,48 mm (only C50/C51)	0A1
Operator size 1, seat Ø 6,38 mm	1A1
Operator size 2, seat Ø 9,55 mm	2A1
Operator size 3, seat Ø 15,80 mm (only C50/C57)	3A1
Operator size 4, seat Ø 22,25 mm (only C50/C57)	4A1
High temperature version	
Operator size 1 (only C50)	1AH
Operator size 2 (only C50)	2AH

K-no.	Code
Standard version	-
Version with PTFE coated screws and compression springs	7125

Version	Code
High Purity white	HPW

Order example	C51	8	D	75	30	5	0	2A1	-	HPW
Type (code)	C51									
Nominal size (code)		8								
Body configuration (code)			D							
Valve body connection (code)				75						
Valve body material (code)					30					
Seal material (code)						5				
Control function (code)							0			
Operator version (code)								2A1		
K-no.									-	
Version (code)										HPW

Dimensions - C50 HPW [mm]

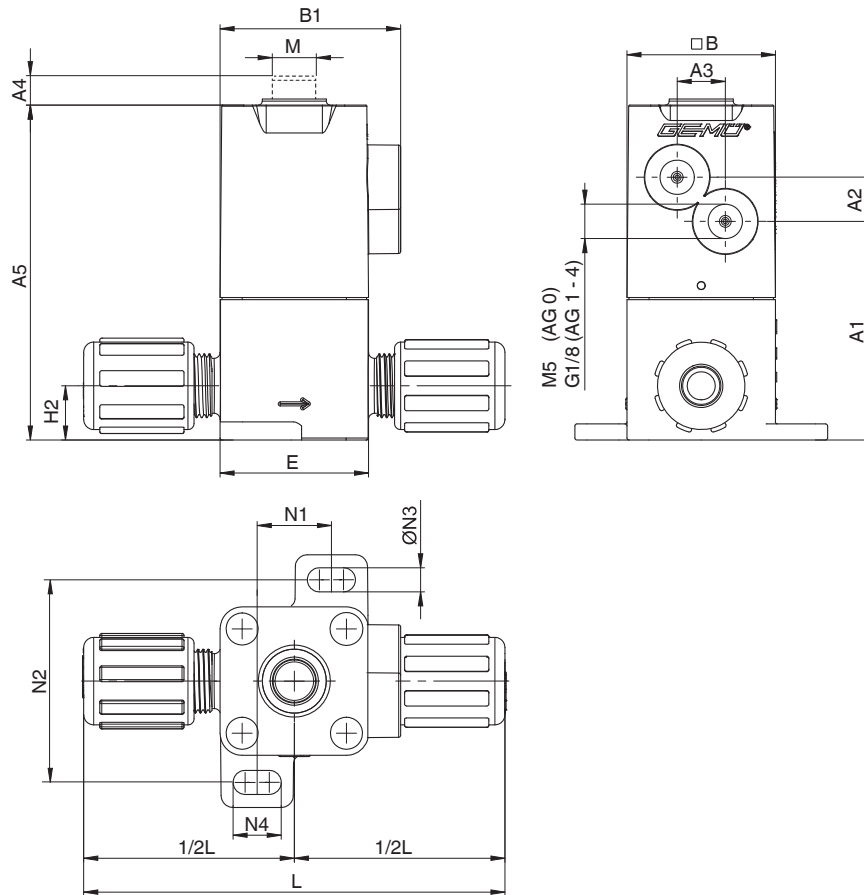

Size	Connection	Operator version	A1	A2	A3	A4	A5	□B	B1	E	H2	L	M	N1	N2	ØN3	N4
1/4"	Flare	0A1	26.6	10	0	4	46	20	26.5	20	7	81.5	-	10	27	3.4	6.4
	PrimeLock	0A1	26.6	10	0	4	46	20	26.5	20	7	80	-	10	27	3.4	6.4
	Flare	1A1	54.5	11	12	3	85	37	45.5	37	13.5	98	M12x1	18.5	50.5	6	12
	PrimeLock	1A1	54.5	11	12	3	85	37	45.5	37	13.5	96	M12x1	18.5	50.5	6	12
3/8"	Flare	1A1	54.5	11	12	3	85	37	45.5	37	13.5	105	M12x1	18.5	50.5	6	12
	PrimeLock	1A1	54.5	11	12	3	85	37	45.5	37	13.5	100	M12x1	18.5	50.5	6	12
1/2"	Flare	1A1	54.5	11	12	3	85	37	45.5	37	13.5	110	M12x1	18.5	50.5	6	12
	PrimeLock	1A1	54.5	11	12	3	85	37	45.5	37	13.5	108	M12x1	18.5	50.5	6	12
	Flare	2A1	65.5	13.5	16	4.5	108	50	57	50	15.5	122	M12x1	31	63.5	6	12
	PrimeLock	2A1	65.5	13.5	16	4.5	108	50	57	50	15.5	120	M12x1	31	63.5	6	12
3/4"	Flare	2A1	65.5	13.5	16	4.5	108	50	57	50	15.5	126.5	M12x1	31	63.5	6	12
	PrimeLock	2A1	65.5	13.5	16	4.5	108	50	57	50	15.5	128	M12x1	31	63.5	6	12
	Flare	3A1	91.5	12	24	5.5	143.5	58	62	58	19	135	M16x1	36	72	7	13
	PrimeLock	3A1	91.5	17	24	5.5	143.5	58	62	58	19	154	M16x1	36	72	7	13
1"	Flare	3A1	91.5	12	24	5.5	143.5	58	62	58	19	155	M16x1	36	72	7	13
	PrimeLock	3A1	91.5	17	24	5.5	143.5	58	62	58	19	155	M16x1	36	72	7	13
	Flare	4A1	119.5	18.5	37	7.5	184	85	86	85	24.5	182.5	M16x1	60	103	9	15
	PrimeLock	4A1	119.5	18.5	37	7.5	184	85	86	85	24.5	183	M16x1	60	103	9	15
1 1/4"	Flare	4A1	119.5	18.5	37	7.5	184	85	86	85	24.5	182.5	M16x1	60	103	9	15
	PrimeLock	4A1	119.5	18.5	37	7.5	184	85	86	85	24.5	204	M16x1	60	103	9	15

Dimensions - C50 HPW [mm]

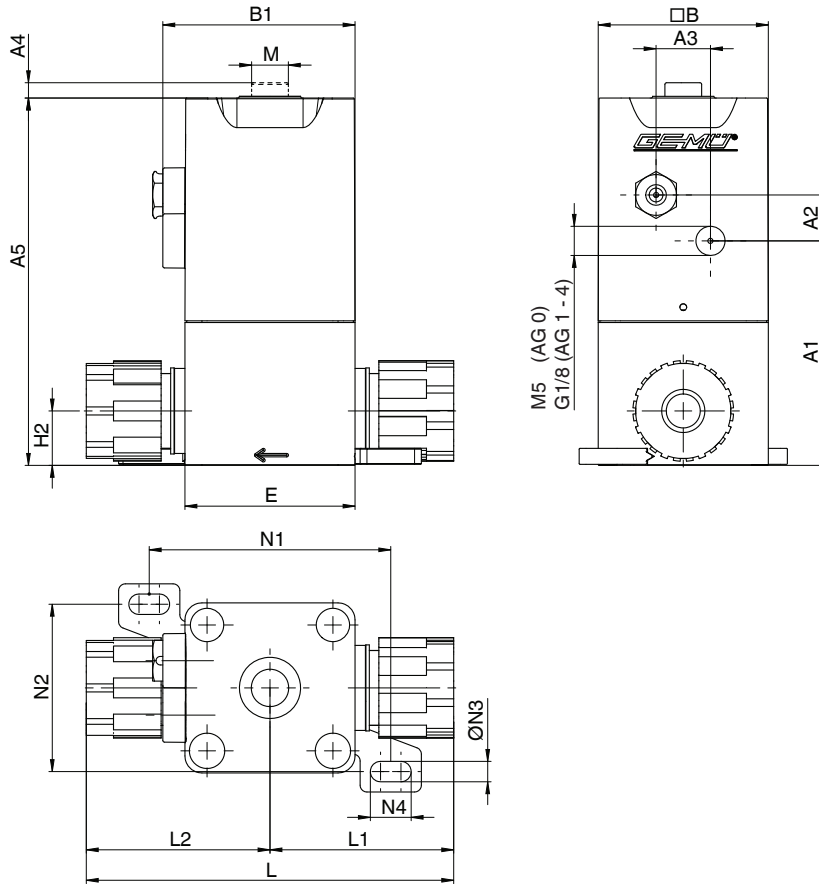

Size	Connection	Operator version	A1	A2	A3	A4	A5	□B	B1	E	H2	L	M	N1	N2	ØN3	N4				
1/4"	Pillar Super 300 Type	0A1*	-	10	0	4	-	20	26.5	20	-	58	-	-	-	-	-				
		1A1	54.5	11	12	3	85	37	45.5	37	13.5	75	M12x1	58	39	6	12				
3/8"		1/2"	3/4"	1"	1 1/4"	1A1	56.5	11	12	3	87	37	45.5	37	15.5	87	M12x1	58	39	6	12
2A1						66	13.5	16	4.5	108.5	50	57	50	16	108	M12x1	71	49	6	12	
3A1						93	12	24	5.5	145	58	62	65	20.5	137	M16x1	89	60	7	13	
4A1						120.5	18.5	37	7.5	185	85	86	93	26	179	M16x1	118	74	9	15	
4A1						128	18.5	37	7.5	192.5	85	86	93	33.5	217	M16x1	118	74	9	15	
1/4"		Nexus Connect®	0A1*	-	10	0	4	-	20	26.5	20	-	58	-	-	-	-	-			
1/4"			1A1	54.5	11	12	3	83.5	37	45.5	37	13.5	75	M12x1	58	39	6	12			
3/8"			1A1	56.5	11	12	3	87	37	45.5	37	15.5	84	M12x1	58	39	6	12			
1/2"	2A1		66	13.5	16	4.5	108.5	50	57	50	16	104.5	M12x1	71	49	6	12				
3/4"	3A1		93	12	24	5.5	145	58	62	65	20.5	132	M16x1	89	60	7	13				
1"	4A1		120.5	18.5	37	7.5	185	85	86	93	26	170.5	M16x1	118	74	9	15				

*Actuator size 0 has no mounting lugs, but a threaded hole for fixing the valve.

Dimensions - C51 HPW [mm]

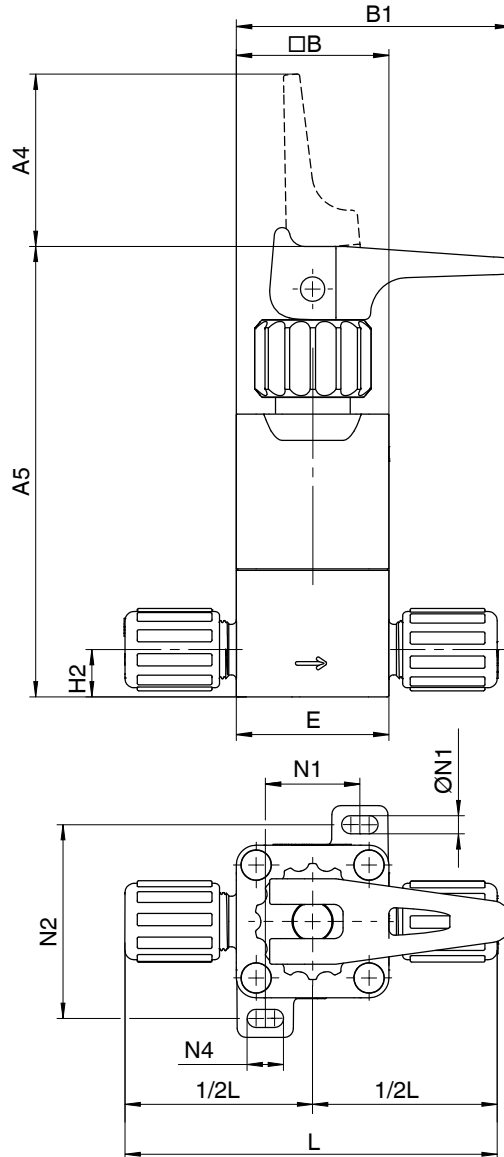

Size	Connection	Operator version	A4	A5	□B	B1	E	H2	L	N1	N2	ØN3	N4
1/4"	Flare	0A1	21	53.5	20	35	20	7	81.5	10	27	3.4	6.4
	PrimeLock	0A1	21	53.5	20	35	20	7	80	10	27	3.4	6.4
	Flare	1A1	30	114	37	57	37	13.5	98	18.5	50.5	6	12
	PrimeLock	1A1	30	114	37	57	37	13.5	96	18.5	50.5	6	12
3/8"	Flare	1A1	30	114	37	57	37	13.5	105	18.5	50.5	6	12
	PrimeLock	1A1		114	37	57	37	13.5	100	18.5	50.5	6	12
1/2"	Flare	1A1	30	114	37	57	37	13.5	110	18.5	50.5	6	12
	PrimeLock	1A1	30	114	37	57	37	13.5	108	18.5	50.5	6	12
	Flare	2A1	54.5	146.5	50	90	50	15.5	122	31	63.5	6	12
	PrimeLock	2A1	54.5	146.5	50	90	50	15.5	120	31	63.5	6	12
3/4"	Flare	2A1	54.5	146.5	50	90	50	15.5	126.5	31	63.5	6	12
	PrimeLock	2A1	54.5	146.5	50	90	50	15.5	128	31	63.5	6	12

Dimensions C51 HPW [mm]

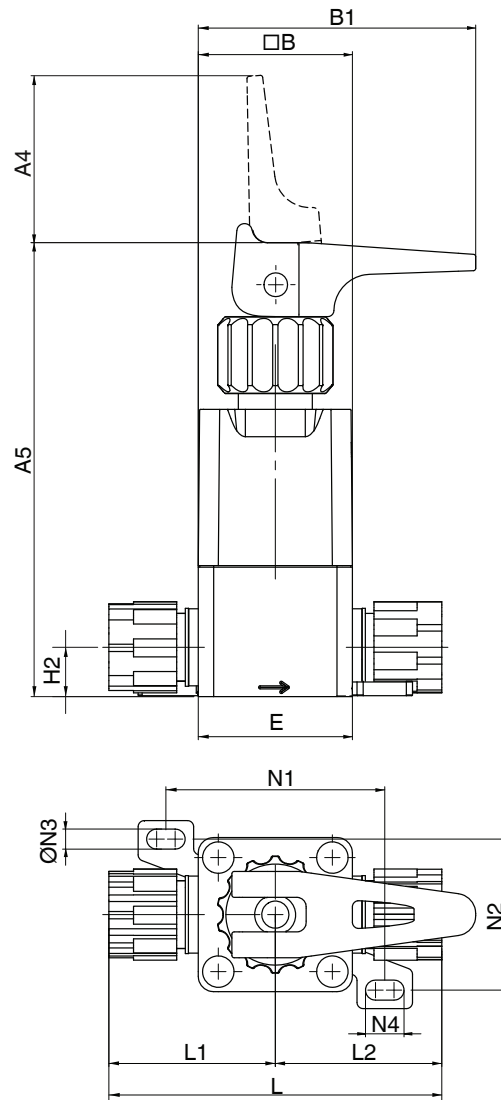

Size	Connection	Operator version	A4	A5	□B	B1	E	H2	L	N1	N2	ØN3	N4
1/4"	Pillar Super 300 Type	0A1*	21	-	20	35	20	-	-	-	-	-	-
		1A1	30	114	37	57	37	13.5	75	58	39	6	12
3/8"	Pillar Super 300 Type	1A1	30	116	37	57	37	15.5	87	58	39	6	12
1/2"		2A1	39.5	163	50	90	50	16	108	71	49	6	12
1/4"	Nexus Connect®	0A1*	21	-	20	35	20	-	58	-	-	-	-
		1A1	30	114	37	57	37	13.5	75	58	39	6	12
3/8"	Nexus Connect®	1A1	30	116	37	57	37	15.5	84	58	39	6	12
1/2"		2A1	39.5	163	50	90	50	16	104.5	71	49	6	12

*Actuator size 0 has no mounting lugs, but a threaded hole for fixing the valve.

Dimensions C57 HPW [mm]

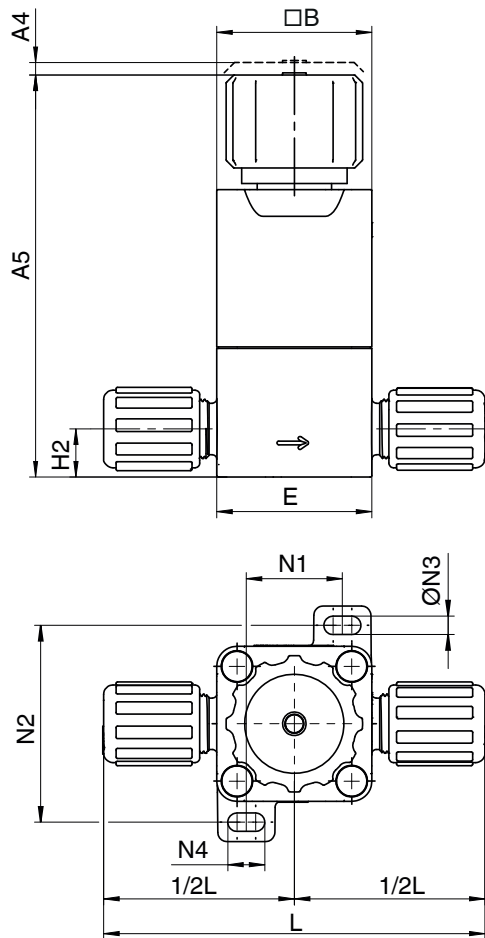

Size	Connection	Operator version	A4	A5	□B	E	H2	L	N1	N2	ØN3	N4
1/4"	Flare	1A1	2.5	106	37	37	13.5	98	18.5	50.5	6	12
	PrimeLock	1A1	2.5	106	37	37	13.5	96	18.5	50.5	6	12
3/8"	Flare	1A1	2.5	106	37	37	13.5	105	18.5	50.5	6	12
	PrimeLock	1A1	2.5	106	37	37	13.5	100	18.5	50.5	6	12
1/2"	Flare	1A1	2.5	106	37	37	13.5	110	18.5	50.5	6	12
	PrimeLock	1A1	2.5	106	37	37	13.5	108	18.5	50.5	6	12
	Flare	2A1	4	130	50	50	15.5	122	31	63.5	6	12
	PrimeLock	2A1	4	130	50	50	15.5	120	31	63.5	6	12
3/4"	Flare	2A1	4	130	50	50	15.5	126.5	31	63.5	6	12
	PrimeLock	2A1	4	130	50	50	15.5	128	31	63.5	6	12
	Flare	3A1	5.5	155	58	58	19	135	36	72	7	13
	PrimeLock	3A1	5.5	155	58	58	19	154	36	72	7	13
1"	Flare	3A1	5.5	155	58	58	19	155	36	72	7	13
	PrimeLock	3A1	5.5	155	58	58	19	155	36	72	7	13
	Flare	4A1	7.5	178.5	85	85	24.5	182.5	60	103	9	15
	PrimeLock	4A1	5.5	178.5	85	85	24.5	183	60	103	9	15
1 1/4"	Flare	4A1	7.5	178.5	85	85	24.5	198.5	60	103	9	15
	PrimeLock	4A1	7.5	178.5	85	85	24.5	204	60	103	9	15

Dimensions C57 HPW [mm]

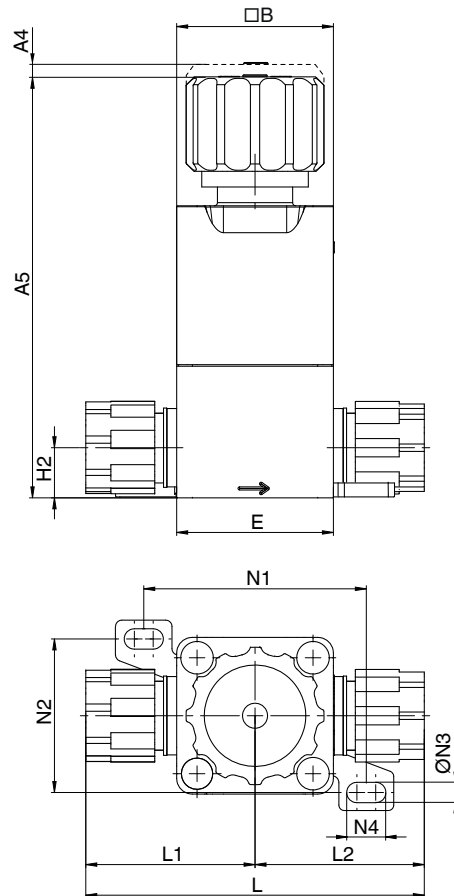

Size	Connection	Operator version	A4	A5	□B	E	H2	L	N1	N2	ØN3	N4
1/4"	Pillar Super 300 Type	1A1	2.5	106	37	37	13.5	75	58	39	6	12
3/8"		1A1	2.5	108	37	37	15.5	87	58	39	6	12
1/2"		2A1	4	130	50	50	16	108	71	49	6	12
3/4"		3A1	5.5	158	58	65	20.5	137	89	60	7	13
1"		4A1	7.5	179.5	85	93	26	179	118	74	9	15
1 1/4"		4A1	7.5	179.5	85	93	33.5	217	118	74	9	15
1/4"	Nexus Connect®	1A1	2.5	106	37	37	13.5	58	58	39	6	12
1/4"		1A1	2.5	108	37	37	15.5	75	58	39	6	12
1/2"		2A1	4	130	50	50	16	104.5	71	49	6	12
3/4"		3A1	5.5	158	58	65	20.5	132	89	60	7	13
1"		4A1	7.5	179.5	85	93	26	170.5	118	74	9	15

Overlap dimensions and thread sizes of flare connections

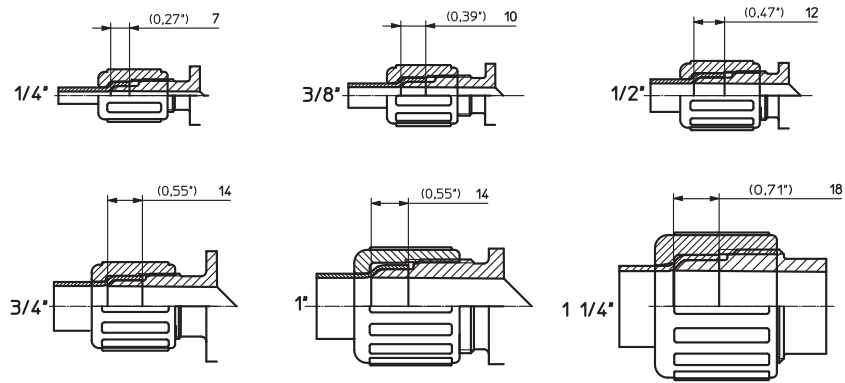

Tube size	Thread designation	Standard	A mm [inch]
1/4"	1/2"-20-UNF	ANSI B 1.1	7.0 [0,27"]
3/8"	5/8"-20-UN	ANSI B 1.1	10.0 [0,39"]
1/2"	3/4"-20-UNEF	ANSI B 1.1	12.0 [0,47"]
3/4"	1"-20-UNEF	ANSI B 1.1	14.0 [0,55"]
1"	1 7/16"-12-UN	ANSI B 1.1	14.0 [0,55"]
1 1/4"	1 3/4"-8-UN	ANSI B 1.1	18.0 [0,71"]

Tolerances

The **CleanStar**® plastic parts are manufactured to DIN 16901-140.

Accessory for GEMÜ C50

GEMÜ C12A

Limit switch box for pneumatic actuators



Multi-port valve block systems

Customised solutions

Based on the GEMÜ C50, C51 and C57 valve types. GEMÜ implements customised multi-port valve solutions, which can be used for many different applications through selection of the suitable body/block material.

Thanks to the mechanical manufacturing of the valve bodies, multi-port valve block solutions with a very wide variety of connection types are also possible in combinations depending on the requirements.



Features	Main advantages / customer benefits
Fully-integrated system solutions (valve functions, fittings, sensor system, check valves, tank/housing walls)	Compact design, low space requirement, logistical advantage, reduction of installation time, few connection points, low maintenance, cost-effective
HP version (cleanroom production), HPS and standard	Suitable for many application areas
Bodies made of all machinable materials (PTFE, PVDF, PP, PVC, if necessary stainless steel)	Materials are media-specific, matched to requirements and cost-effective

For further valves, high purity products, accessories and other products, please see our Product Range catalogue and Price List.
Contact GEMÜ.

GEMÜ VALVES, MEASUREMENT
AND CONTROL SYSTEMS

