

GEMÜ 533 eSyStep

Motorized globe valve



Features

- Open/close function or with integrated positioner
- Parameterisable and controllable via IO-Link
- Linear or modified equal-percentage control characteristics
- On-site or remote end position programming via programming input
- Various functions integrated (e.g. feedback, stroke limiter, etc.)
- Suitable for vacuum up to 20 mbar (a)

Description

The GEMÜ 533 eSyStep is a motorized 2/2-way globe valve. The eSyStep electric actuator is available as On/Off actuator or with integrated positioner. The valve spindle is sealed by a self-adjusting gland packing providing low-maintenance and reliable valve spindle sealing even after a long service life. A wiper ring fitted in front of the gland packing protects the seal against contamination and damage. An integral optical and electrical position indicator is standard. The self-locking actuator holds its position in a stable manner when idle and in the event of power supply failure.

Technical specifications

- **Media temperature:** -40 to 180 °C
- **Ambient temperature:** 0 Up to 60 °C
- **Operating pressure :** 0 Up to 40 bar
- **Nominal sizes:** DN 15 to 50
- **Body configurations:** Straight through body
- **Connection types:** Flange
- **Connection standards :** ANSI | ASME | EN | ISO | JIS
- **Body materials:** 1.4408, investment casting material | EN-GJS-400-18-LT (GGG 40.3)
- **Seat seal materials:** 1.4404 | PTFE | PTFE, reinforced
- **Supply voltage:** 24 V DC
- **Actuating speed:** max. 3 mm/s
- **Protection class :** IP 65
- **Conformities:** EAC | FDA | Oxygen | Regulation (EC) No. 1935/2004 | TA Luft (German Clean Air Act)

Technical data depends on the respective configuration



further information
webcode: GW-533



Product description

Construction

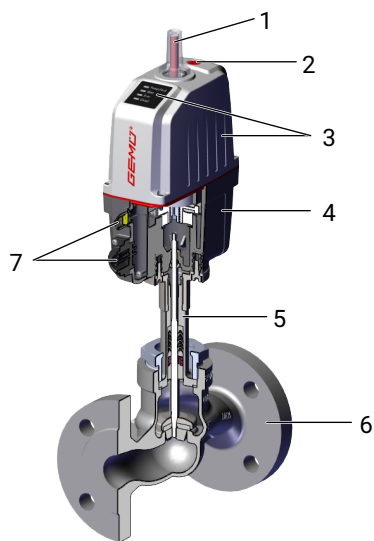

Item	Name	Materials
1	Optical position indicator	PA 12
2	Manual override	
3	Actuator top with LED display	Reinforced polyamide
4	Actuator base	Reinforced polyamide
5	Distance piece with leak detection hole	
6	Valve body	1.4408, EN-GJS-400-18-LT (GGG 40.3)
7	Electrical connections	

GEMÜ CONEXO

The interaction of valve components that are equipped with RFID chips and an associated IT infrastructure actively increase process reliability.



Thanks to serialization, every valve and every relevant valve component such as the body, actuator or diaphragm, and even automation components, can be clearly traced and read using the CONEXO pen RFID reader. The CONEXO app, which can be installed on mobile devices, not only facilitates and improves the "installation qualification" process, but also makes the maintenance process much more transparent and easier to document. The app actively guides the maintenance technician through the maintenance schedule and directly provides him with all the information assigned to the valve, such as test reports, testing documentation and maintenance histories. The CONEXO portal acts as a central element, helping to collect, manage and process all data.

For further information on GEMÜ CONEXO please visit:

www.gemu-group.com/conexo

Ordering

GEMÜ Conexo must be ordered separately with the ordering option "CONEXO".

In the corresponding design with CONEXO, this product has an RFID chip for electronic identification purposes. The position of the RFID chip can be seen below.

For electronic identification purposes, each replaceable component contained in the product is equipped with an RFID chip (1). Where you can find the RFID chip differs from product to product.

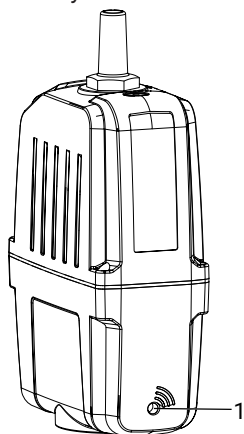

Actuator RFID chip

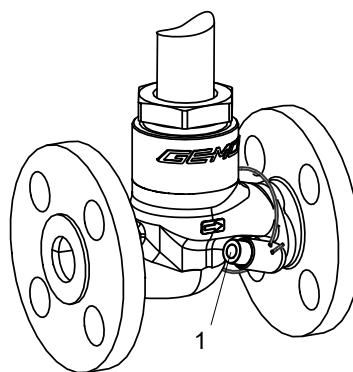

Valve body RFID chip

The CONEXO pen helps read out information stored in these RFID chips. The CONEXO app or CONEXO portal is required to view this information.

Kv value diagram

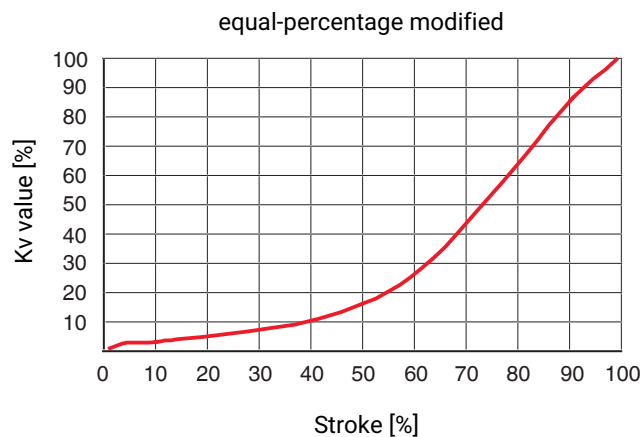
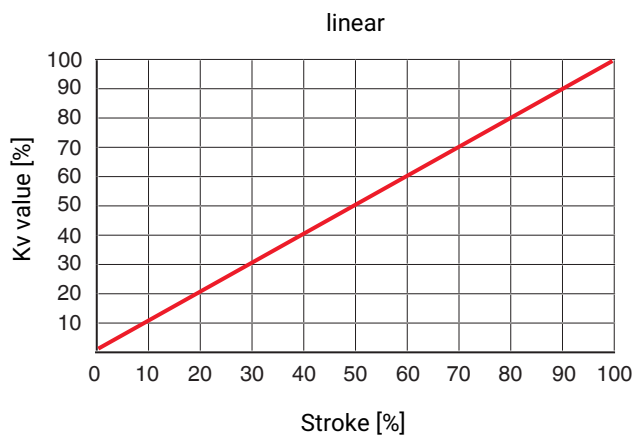

The diagram shows the approximative curve of the Kv value characteristic. The characteristic may deviate depending on valve body, nominal size, regulating cone and valve stroke.

Regulating needle / Regulating cone

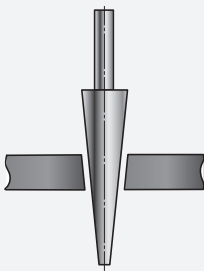
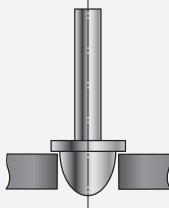
Regulating needle	Regulating cone
	
Regulating needle: RAxxx – RCxxx (reduced valve seat)	Regulating cone: DN 15 - 50

Overview of available functions

Function	Control module – OPEN/CLOSE control (Code AE, A5, A6)	Control module – positioner (Code S0, S5, S6)
OPEN/CLOSE control	X	X
Positioner	-	X
Manual override	X	X
Optical status and position indicator	X	X
On-site initialization	X	X
Deactivation of on-site initialization	X	X
Initialization via digital input	X	X
Initialization via IO-Link	X	X
Feedback for operating mode	X	X
Actuation OPEN	X	X
Actuation CLOSED	X	X
Actuation, analogue	-	X
Position feedback OPEN	X	X
Position feedback CLOSED	X	X
Position feedback analogue	-	X
Location function	X	X
Error output	X	X
Actuating speed adjustable	X	-
Actuating force adjustable	X	X
Inversion of LED colours	X	X
Cycle counter	X	-
Error counter	X	-
Operating time determination	X	X
Switch point setting (tolerance)	X	X
Inversion input/output logic	X	X
Adjustable error action	X	X
Safe/On	X	X
Direction reversal	-	X
Open tight	-	X
Close tight	-	X
Split range	-	X
Stroke limiter/seal adjuster	-	X
Operating range	-	X

Availability

Availability of valve bodies

Flange

DN	Connection type code ¹⁾					
	8		11	39		48
	Material code ²⁾					
	37	90	37		90	37
15	-	X	X	X	X	X
20	-	X	X	X	X	X
25	-	X	X	X	X	X
32	-	X	X	X	X	-
40	-	X	X	X	X	X
50	X	X	X	X	X	X

1) Connection type

Code 8: Flange EN 1092, PN 16, form B, face-to-face dimension FTF EN 558 series 1, ISO 5752, basic series 1

Code 11: Flange EN 1092, PN 40, form B, face-to-face dimension FTF EN 558 series 1, ISO 5752, basic series 1

Code 39: Flange ANSI Class 125/150 RF, face-to-face dimension FTF EN 558 series 1, ISO 5752, basic series 1

Code 48: Flange JIS 20K, face-to-face dimension FTF EN 558 series 10, ASME/ANSI B16.10 table 1, column 16, DN 50 drilled to JIS 10K

2) Valve body material

Code 37: 1.4408, investment casting

Code 90: EN-GJS-400-18-LT (GGG 40.3)

Product compliance

	Approved designs		
	Valve body material	Seat seal	Type of design
Food			
FDA Regulation (EC) 1935/2004 Regulation (EC) 10/2011	1.4408, investment casting (code 37)	PTFE (code 5) PTFE, glass fibre reinforced (code 5G) 1.4404 (code 10)	Spindle seal PTFE-PTFE (code 2013)

Order data

The order data provide an overview of standard configurations.

Please check the availability before ordering. Other configurations available on request.

Order codes

1 Type	Code
Globe valve, motorized, eSyStep	533

2 DN	Code
DN 15	15
DN 20	20
DN 25	25
DN 32	32
DN 40	40
DN 50	50

3 Housing configuration	Code
2/2-way body	D

4 Connection type	Code
Flange EN 1092, PN 16, form B, face-to-face dimension FTF EN 558 series 1, ISO 5752, basic series 1	8
Flange EN 1092, PN 40, form B, face-to-face dimension FTF EN 558 series 1, ISO 5752, basic series 1	11
Flange ANSI Class 125/150 RF, face-to-face dimension FTF EN 558 series 1, ISO 5752, basic series 1	39
Flange JIS 20K, face-to-face dimension FTF EN 558 series 10, ASME/ANSI B16.10 table 1, column 16, DN 50 drilled to JIS 10K	48

5 Valve body material	Code
Investment casting material	
1.4408, investment casting	37
SG iron material	
EN-GJS-400-18-LT (GGG 40.3)	90

6 Seat seal	Code
PTFE	5
PTFE, glass fibre reinforced	5G
1.4404	10

7 Voltage/Frequency	Code
24 V DC	C1

8 Control module	Code
ON/OFF actuator, additional end position indicators	AE
OPEN/CLOSE drive, additional end position feedback configured for emergency power supply module (NC)	A5
OPEN/CLOSE drive, additional end position feedback configured for emergency power supply module (NO)	A6
Positioner	S0

8 Control module	Code
Positioner, configured for emergency power supply module (NC)	S5
Positioner configured for emergency power supply module (NO)	S6

9 Regulating cone	Code
Without	
Please find the number of the optional regulating cone (R-No.) for the linear or equal-percentage modified regulating cone in the Kv value table.	R...

10 Actuator version	Code
Actuator size 0	0A
Actuator size 1	1A

11 Type of design	Code
Standard	
PTFE-PTFE spindle seal	2013

12 Special version	Code
Standard	
Special version for oxygen, (max. temperature 60 °C; max. operating pressure 10 bar), media wetted seal materials and auxiliary materials with BAM testing	S

13 CONEXO	Code
Without	
Integrated RFID chip for electronic identification and traceability	C

Order example

Ordering option	Code	Description
1 Type	533	Globe valve, motorized, eSyStep
2 DN	20	DN 20
3 Housing configuration	D	2/2-way body
4 Connection type		
5 Valve body material	37	1.4408, investment casting
6 Seat seal	5	PTFE
7 Voltage/Frequency	C1	24 V DC
8 Control module	S0	Positioner
9 Regulating cone	R....	Please find the number of the optional regulating cone (R-No.) for the linear or equal-percentage modified regulating cone in the Kv value table.
10 Actuator version	0A	Actuator size 0
11 Type of design		Standard
12 Special version		Standard
13 CONEXO		Without

Technical data

Medium

Working medium: Corrosive, inert, gaseous and liquid media which have no negative impact on the physical and chemical properties of the body and seal material.

Max. permissible viscosity: 600 mm²/s
Other versions for lower / higher temperatures and higher viscosities on request.

Temperature

Media temperature: -40 – 180 °C
For material code 37 + K-no. 2013: -40 to 180 °C

Ambient temperature: 0 – 60 °C
depending on version and/or operating parameters (see chapter Duty cycle and service life)

Pressure

Operating pressure:

DN	Actuator size 0 (code 0A)	Actuator size 1 (code 1A), Open/Close valve (code A0)	Actuator size 1 (code 1A), control valve (code S0)
15	15	40	25
20	10	32	15
25	6	23	10
32	-	15	6.5
40	-	9	4
50	-	6	1

All pressures are gauge pressures.
For max. operating pressures the pressure / temperature correlation must be observed.
Higher operating pressures on request

Leakage rate:

Open/Close valve

Seat seal	Standard	Test procedure	Leakage rate	Test medium
Metal	DIN EN 12266-1	P12	F	Air
EPDM, FKM, PTFE	DIN EN 12266-1	P12	A	Air

Control valve

Seat seal	Standard	Test procedure	Leakage rate	Test medium
Metal	DIN EN 60534-4	1	IV	Air
PTFE, FKM, EPDM	DIN EN 60534-4	1	VI	Air

Technical data

Pressure/temperature correlation:

Connection type code ¹⁾	Material code ²⁾	Max. allowable operating pressures in bar at temperature in °C			
		RT	100	150	200
8	37	16.0	16.0	14.5	13.4
11	37	40.0	40.0	36.3	33.7
39	37	19.0	16.0	14.8	13.6
8	90	16.0	16.0	15.5	14.7
39	90	17.0	16.0	14.8	13.9

1) **Connection type**

Code 8: Flange EN 1092, PN 16, form B, face-to-face dimension FTF EN 558 series 1, ISO 5752, basic series 1

Code 11: Flange EN 1092, PN 40, form B, face-to-face dimension FTF EN 558 series 1, ISO 5752, basic series 1

Code 39: Flange ANSI Class 125/150 RF, face-to-face dimension FTF EN 558 series 1, ISO 5752, basic series 1

2) **Valve body material**

Code 37: 1.4408, investment casting

Code 90: EN-GJS-400-18-LT (GGG 40.3)

Kv values:

Open/Close valve

DN 15:	4.6 m ³ /h
DN 20:	8.0 m ³ /h
DN 25:	13.0 m ³ /h
DN 32:	22.0 m ³ /h
DN 40:	35.0 m ³ /h
DN 50:	50.0 m ³ /h

Standard regulating cone

DN	Kv values	Operating pressure	Actuator version	linear	equal percentage
15	4.0	15.0	0A	RS480	RS500
		25.0	1A	RS481	RS501
20	6.3	10.0	0A	RS482	RS502
		15.0	1A	RS483	RS503
25	10.0	6.0	0A	RS484	RS504
		10.0	1A	RS485	RS505
32	16.0	6.5	1A	RS486	RS506
40	25.0	4.0	1A	RS488	RS508
50	40.0	1.0	1A	RS490	RS510

Kv values in m³/h

Pressures in bar

Kv values:

Standard regulating cone with reduced seat
Valve body material 1.4408 (code 37)

DN	Operating pressure [bar]		Kv value [m ³ /h]	Seat seal Code	Regulating cone number	
	0A	1A			linear	equal-percentage (mod.)
15	40,0	-	0,1 ¹⁾	10	RA105	RA310
	40,0	-	0,16 ¹⁾	10	RB113	RA311
	40,0	-	0,25 ¹⁾	10	RB114	RB309
	40,0	-	0,4 ¹⁾	10	RB115	RB310
	40,0	-	0,63 ¹⁾	10	RC109	RC309
	40,0	-	1,0 ¹⁾	10	RC110	RC310
	40,0	-	1,6	5, 5G	RD109	RD309
	30,0	-	2,5	5, 5G	RE113	RE313
20	40,0	-	1,6	5, 5G	RD110	RD310
	40,0	-	2,5	5, 5G	RE114	RE314
	25,0	-	4,0	5, 5G	RF116	RF316
25	35,0	-	2,5	5, 5G	RE115	RE315
	25,0	-	4,0	5, 5G	RF117	RF317
	15,0	-	6,3	5, 5G	RG118	RG318
32	25,0	-	4,0	5, 5G	RF118	RF318
	15,0	-	6,3	5, 5G	RG119	RG319
	10,0	-	10,0	5, 5G	RH113	RH313
40	15,0	-	6,3	5, 5G	RG120	RG320
	10,0	-	10,0	5, 5G	RH114	RH314
	6,0	-	16,0	5, 5G	RJ109	RJ309
50 ²⁾	10,0	-	10,0	5, 5G	RH115	RH315
	6,0	-	16,0	5, 5G	RJ110	RJ310
	-	6,5	25,0	5, 5G	RK105	RK305

1) metal seated

2) only for connection type code 8, 39, 48

Kv values determined in accordance with DIN EN 60534. The Kv value specifications refer to the largest actuator for the respective nominal size. The Kv values for other product configurations (e.g. other connections or body materials) may differ.

Product compliance

Machinery Directive:	2006/42/EC
Pressure Equipment Directive:	2014/68/EU
Food:	Regulation (EC) No. 1935/2004* Regulation (EC) No. 10/2011* FDA* * depending on version and/or operating parameters
EMC Directive:	2014/30/EU
RoHS Directive:	2011/65/EU

Mechanical data

Protection class:	IP 65 acc. to EN 60529	
Actuating speed:	Actuator size 0	Max. 3 mm/s
	Actuator size 1	max. 2.5 mm/s
Weight:	Actuator	
	Actuator size 0 (code 0A)	0.95 kg
	Actuator size 1 (code 1A)	1.88 kg

Valve body

DN	Weight
15	2.2
20	3.0
25	3.7
32	5.3
40	6.3
50	11.5

Weights in kg

Mechanical environmental conditions:	Class 4M8 acc. to EN 60721-3-4:1998
Vibration:	5g acc. to IEC 60068-2-6 Test Fc
Shock:	25g acc. to 60068-2-27 Test Ea

Actuator duty cycle and service life

Service life: **Control operation** - Class C according to EN 15714-2 (1,800,000 starts and 1200 starts per hour).
Open/Close duty - At least 500,000 switching cycles at room temperature and permissible duty cycle.

Duty cycle: Control module Open/Close control (code AE, A5, A6)
 Duty cycle with full valve lift and playing time 10 minutes.

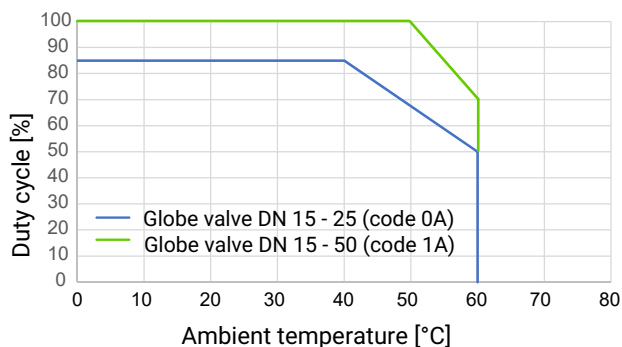

Control module Positioner (code S0, S5, S6), Open/Close duty

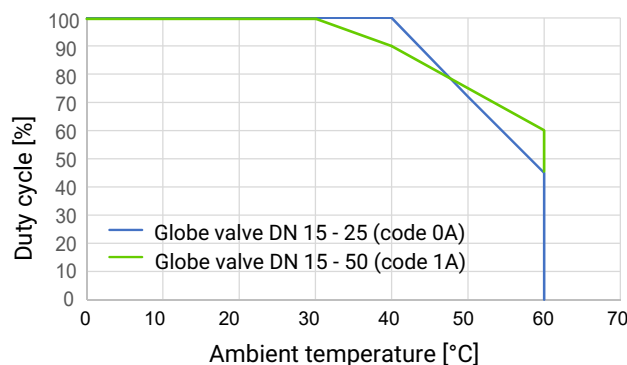

Control module positioner (code S0, S5, S6), control operation - class C acc. to EN 15714-2

- DN 15 - 25 (code 0A) up to 50 °C ambient temperature
- DN 15 - 50 (code 1A) up to 60 °C ambient temperature

The specified characteristics and values apply to the default setting.

With reduced forces, higher duty cycles and/or higher ambient temperatures are possible. At higher force settings the duty cycle and/or ambient temperature is reduced (for IO-Link parameters see operating instructions).

Electrical data

Supply voltage Uv:	24 V DC \pm 10%	
Rating:	Actuator size 0 (code 0A)	20 W
	Actuator size 1 (code 1A)	60 W
Operation:	Stepper motor, self-locking	
Reverse polarity protection:	Yes	

Analogue input signals – Control module Positioner (code S0, S5, S6)

Set value

Input signal:	0/4 - 20 mA; 0 - 10 V (function selectable via IO-Link)	
Input type:	passive	
Input resistance:	250 Ω	
Accuracy/linearity:	$\leq \pm 0.3\%$ of full scale value	
Temperature drift:	$\leq \pm 0.1\%$ / 10°K	
Resolution:	12 bit	
Reverse polarity protection:	Yes (up to \pm 24 V DC)	

Digital input signals

Inputs:	Function selectable via IO-Link (see table Overview of available functions – Input and output signals)	
Input voltage:	24 V DC	
Logic level "1":	> 15.3 V DC	
Logic level "0":	< 5.8 V DC	
Input current:	typically < 0.5 mA	

Analogue output signals – Control module Positioner (code S0, S5, S6)

Actual value

Output signal:	0/4 - 20 mA; 0 - 10 V (function selectable via IO-Link)	
Output type:	Active	
Accuracy:	$\leq \pm 1\%$ of full scale value	
Temperature drift:	$\leq \pm 0.1\%$ / 10°K	
Load resistor:	≤ 750 k Ω	
Resolution:	12 bit	
Short-circuit proof:	Yes	

Digital output signals

Outputs:	Function selectable via IO-Link (see table Overview of available functions – Input and output signals)
Type of contact:	Push-Pull
Switching voltage:	Power supply U_v
Switching current:	≤ 140 mA
Short-circuit proof:	Yes

Communication

Interface:	IO-Link
Function:	Parameterization/process data
Transmission rate:	38400 baud
Frame type in Operate:	2.5 (eSyStep ON/OFF, code AE, A5, A6) 2.V (eSyStep positioner, code S0, S5, S6), PDout 3Byte; PDin 3 Byte; OnRequestData 2 Byte
Min. cycle time:	2.3 ms (eSyStep ON/OFF, code AE, A5, A6) 20 ms (eSyStep positioner, code S0, S5, S6)
Vendor-ID:	401
Device-ID:	1906701 (eSyStep ON/OFF, code AE, A5, A6) 1906801 (eSyStep position controller code S0, S5, S6), 1906802 (eSyStep position controller code S0, S5, S6) from software version V1.0.3.3 (from Nov 2024)
Product-ID:	eSyStep On/Off (code AE, A5, A6) eSyStep Positioner (code S0, S5, S6)
ISDU support:	Yes
SIO operation:	Yes
IO-Link specification:	V1.1

IODD files can be downloaded via <https://ioddfinder.io-link.com/> or www.gemu-group.com.

Electrical connection

Position of the connectors

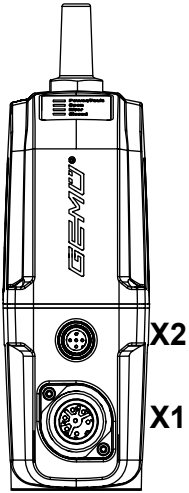

Electrical connection

Connection X1

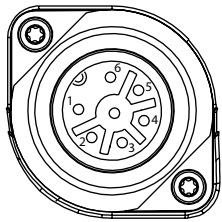

7-pin plug, Binder, type 693

Pin	Signal name
1	Uv, 24 V DC supply voltage
2	GND
3	Digital input 1
4	Digital input 2
5	Digital input/output
6	Digital output, IO-Link
7	n.c.

Connection X2 (only for positioner design)

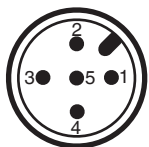

5-pin M12 plug, A-coded

Pin	Signal name
1	I+/U+, set value input
2	I-/U-, set value input
3	I+/U+, actual value output
4	I-/U-, actual value output

Pin	Signal name
5	n.c.

Dimensions

Installation and actuator dimensions

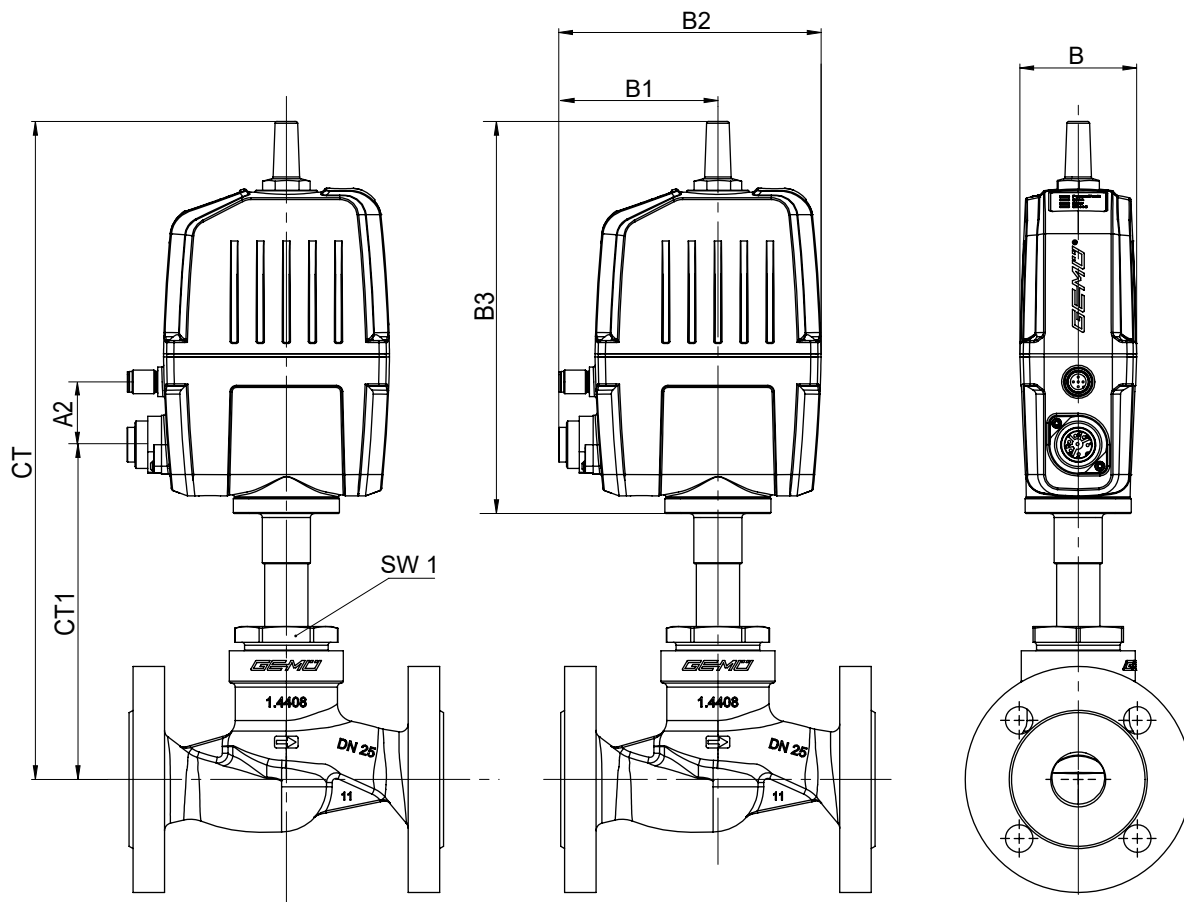

DN	Actuator version	SW1	A2	B	B1	B2	B3	CT	CT1
15	0A	36	32.0	59.4	81.0	133.5	200.5	316.8	152.3
	1A	36	32.5	59.4	82.0	150.0	252.0	366.8	234.8
20	0A	41	32.0	59.4	81.0	133.5	200.5	324.3	159.8
	1A	41	32.5	70.0	82.0	150.0	252.0	374.3	242.3
25	0A	46	32.0	59.4	81.0	133.5	200.5	334.8	170.3
	1A	46	32.5	70.0	82.0	150.0	252.0	384.8	252.8
32	1A	55	32.5	70.0	82.0	150.0	252.0	389.0	257.0
40	1A	60	32.5	70.0	82.0	150.0	252.0	400.5	268.5
50	1A	75	32.5	70.0	82.0	150.0	252.0	408.5	276.5

Dimensions in mm

Dimension A2 only for control module – positioner (code S0, S5, S6)

Body dimensions

Flange EN (code 8)

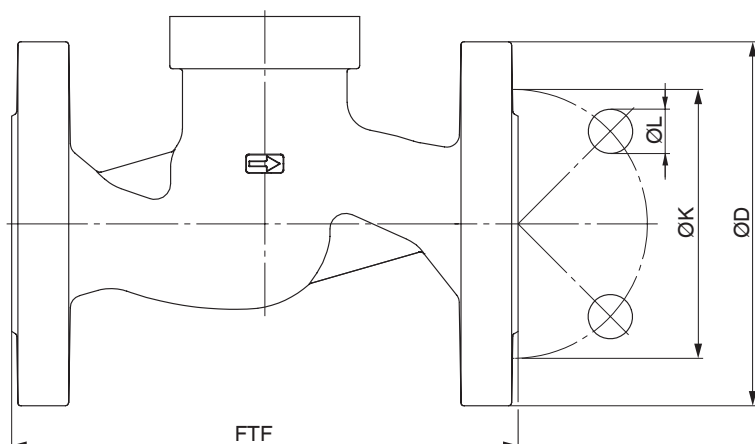

Connection type flange, length EN 558 (code 8)¹⁾, SG iron material (code 90)²⁾

DN	NPS	ø D	FTF	ø k	ø L	n
15	1/2"	95.0	130.0	65.0	14.0	4
20	3/4"	105.0	150.0	75.0	14.0	4
25	1"	115.0	160.0	85.0	14.0	4
32	1¼"	140.0	180.0	100.0	18.0	4
40	1½"	150.0	200.0	110.0	18.0	4
50	2"	165.0	230.0	125.0	18.0	4

Connection type flange, length EN 558 (code 8)¹⁾, investment casting material (code 37)²⁾

DN	NPS	ø D	FTF	ø k	ø L	n
50	2"	165.0	230.0	125.0	18.0	4

Dimensions in mm

n = number of bolts

1) Connection type

Code 8: Flange EN 1092, PN 16, form B, face-to-face dimension FTF EN 558 series 1, ISO 5752, basic series 1

2) Valve body material

Code 37: 1.4408, investment casting

Code 90: EN-GJS-400-18-LT (GGG 40.3)

Flange EN/JIS (code 10, 11, 48)

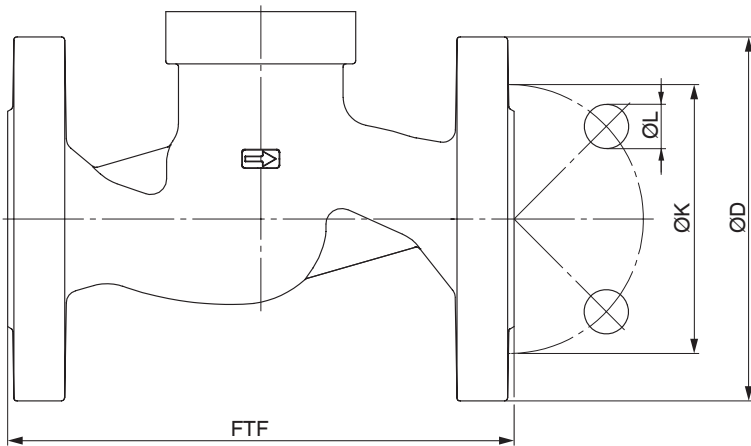

Connection type flange, length EN 558 (code 11),¹⁾ investment casting material (code 37)²⁾

DN	NPS	ø D	FTF	ø k	ø L	n
15	1/2"	95.0	130.0	65.0	14.0	4
20	3/4"	105.0	150.0	75.0	14.0	4
25	1"	115.0	160.0	85.0	14.0	4
32	1¼"	140.0	180.0	100.0	18.0	4
40	1½"	150.0	200.0	110.0	18.0	4
50	2"	165.0	230.0	125.0	18.0	4

Connection type flange, length EN 558 (code 48)¹⁾, investment casting material (code 37)²⁾

DN	NPS	ø D	FTF	ø k	ø L	n
15	1/2"	95.0	108.0	70.0	15.0	4
20	3/4"	100.0	117.0	75.0	15.0	4
25	1"	125.0	127.0	90.0	19.0	4
40	1½"	140.0	165.0	105.0	19.0	4
50	2"	155.0	203.0	120.0	19.0	4

Dimensions in mm

n = number of bolts

1) Connection type

Code 11: Flange EN 1092, PN 40, form B, face-to-face dimension FTF EN 558 series 1, ISO 5752, basic series 1

Code 48: Flange JIS 20K, face-to-face dimension FTF EN 558 series 10, ASME/ANSI B16.10 table 1, column 16, DN 50 drilled to JIS 10K

2) Valve body material

Code 37: 1.4408, investment casting

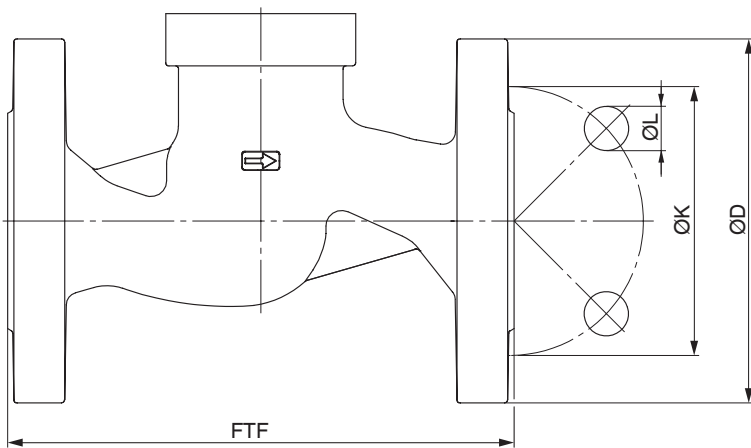
Flange ANSI Class (code 39)

Connection type flange, length EN 558 (code 39)¹⁾, investment casting material (code 37), SG iron material (code 90)²⁾

DN	NPS	ø D	FTF	ø k	ø L	n
15	1/2"	90.0	130.0	60.3	15.9	4
20	3/4"	100.0	150.0	69.9	15.9	4
25	1"	110.0	160.0	79.4	15.9	4
32	1¼"	115.0	180.0	88.9	15.9	4
40	1½"	125.0	200.0	98.4	15.9	4
50	2"	150.0	230.0	120.7	19.0	4

Dimensions in mm

n = number of bolts

1) **Connection type**

Code 39: Flange ANSI Class 125/150 RF, face-to-face dimension FTF EN 558 series 1, ISO 5752, basic series 1

2) **Valve body material**

Code 37: 1.4408, investment casting

Code 90: EN-GJS-400-18-LT (GGG 40.3)

Accessories



GEMÜ 1218

Connector

GEMÜ 1218 is a connector (cable socket/cable plug), 7-pin. Straight or 90° angled plug type.

GEMÜ 1218 Binder connector			
Connection X1 – supply voltage, relay outputs			
Binder plug	468/eSy series mating connector	Terminal compartment/ screws, 7-pin	88220649
		Terminal compartment/ screws, 7-pin, 90°	88377714 ¹⁾
		Terminal compartment/ screws, 7-pin, 90°, fitted with a 2 metre cable set	88770522

1) provided in the scope of delivery



GEMÜ 1219

Cable socket / cable plug M12

The GEMÜ 1219 is a connector (cable socket / cable plug) M12, 5-pin. Straight and/or 90° angled plug type. Defined cable length or with threaded connection without cable. Various materials available for the threaded ring.

Suitable for electrical connection of the connector X2

Description	Length	Order number
5-pin, angle	without cable	88205545 ¹⁾
	2 m cable	88205534
	5 m cable	88205540
	10 m cable	88210911
	15 m cable	88244667
5-pin, straight	without cable	88205544
	2 m cable	88205542
	5 m cable	88205543
	10 m cable	88270972
	15 m cable	88346791

1) provided in the scope of delivery for control module code S0

**GEMÜ 1560****IO-Link master**

The GEMÜ 1560 IO-Link master is used for parametrization, actuation, commissioning and for evaluating process and diagnostics data on products with IO-Link interface with communication standard in accordance with IEC 61131-9. The IO-Link master is available with USB port for use on a computer or with a Bluetooth or WLAN interface for use on mobile devices (iOS and Android). GEMÜ 1560 can be ordered separately or as a set for GEMÜ products including the required adapter.

Description	Order designation	Order number
IO-Link master kit (adapter plus cable)	1560USBS 1 A40A12AU A	99072365
IO-Link master kit (adapter plus cable)	1560 BTS 1 A20A12AA A	99130458

**GEMÜ 1571****Emergency power supply module**

The GEMÜ 1571 capacitive emergency power supply module is suitable for valves with motorized actuators such as GEMÜ eSyStep and eSyDrive as well as the GEMÜ C53 iComLine control valve. In the event of a power failure, the product provides an uninterrupted power supply so that the valve can be moved to the safety position. The emergency power supply module is available individually or with an expansion module and can supply several valves. The input and output voltage is 24 V.

GEMÜ 1571 emergency power supply module			
Input voltage	Output voltage	Capacity	Item number
24 V	24 V	1700 Ws	88660398
24 V	24 V	13200 Ws	88751062

**GEMÜ 1573****Switching power supply unit**

The GEMÜ 1573 switching power supply unit converts unstable input voltages from 100 to 240 V AC into a continuous DC voltage. It can be used as an accessory for valves with motorized actuators e. g. GEMÜ eSyLite, eSyStep und eSyDrive and for additional devices with a 24 V DC power supply. Different power levels, output currents and a 48 V DC version for servoDrive actuators are available.

GEMÜ 1573 switching power supply unit			
Input voltage	Output voltage	Output current	Item number
100 - 240 V AC	24 V DC	5 A	88660400
		10 A	88660401



GEMÜ Gebr. Müller Apparatebau GmbH & Co. KG
Gert-Müller-Platz 1, 74635 Kupferzell, Germany
Phone +49 (0) 7940 1230 · info@gemue.de
www.gemu-group.com