

GEMÜ B4F

Pneumatically operated 2/2-way ball valve

EN

Operating instructions



All rights including copyrights or industrial property rights are expressly reserved.

Keep the document for future reference.

© GEMÜ Gebr. Müller Apparatebau GmbH & Co. KG
24.06.2024

Contents

1 General information	4	21 EU Declaration of Conformity in accordance with 2014/68/EU (Pressure Equipment Directive)	32
1.1 Information	4		
1.2 Symbols used	4		
1.3 Definition of terms	4		
1.4 Warning notes	4		
2 Safety information	5		
3 Product description	5		
3.1 Construction	5		
3.2 Pressure-relief hole	5		
3.3 Control ball	5		
3.4 Description	5		
3.5 Function	6		
3.6 Product label	6		
4 GEMÜ CONEXO	6		
5 Correct use	7		
6 Order data	8		
6.1 Order codes	8		
6.2 Order example	10		
7 Technical data	11		
7.1 Medium	11		
7.2 Temperature	11		
7.3 Pressure	11		
7.4 Product conformity	15		
7.5 Mechanical data	15		
8 Dimensions	17		
8.1 Actuator dimensions	17		
8.2 Ball valve	21		
9 Manufacturer's information	24		
9.1 Delivery	24		
9.2 Packaging	24		
9.3 Transport	24		
9.4 Storage	24		
10 Installation in piping	24		
10.1 Preparing for installation	24		
10.2 Installation with flanged connections	25		
10.3 After the installation	25		
11 Pneumatic connection	26		
11.1 Control functions	26		
11.2 Optical position indicator	26		
11.3 Connecting the control medium	26		
12 Setting the end positions	27		
13 Commissioning	27		
14 Operation	27		
15 Troubleshooting	28		
16 Inspection/maintenance	29		
16.1 General information regarding actuator re- placement	29		
16.2 Spare parts	30		
17 Removal from piping	30		
18 Disposal	30		
19 Returns	30		
20 EU Declaration of Incorporation according to the EC Machinery Directive 2006/42/EC, Annex II B ...	31		

1 General information

1.1 Information

- The descriptions and instructions apply to the standard versions. For special versions not described in this document the basic information contained herein applies in combination with any additional special documentation.
- Correct installation, operation, maintenance and repair work ensure faultless operation of the product.
- Should there be any doubts or misunderstandings, the German version is the authoritative document.
- Contact us at the address on the last page for staff training information.

1.2 Symbols used

The following symbols are used in this document:

Symbol	Meaning
●	Tasks to be performed
▶	Response(s) to tasks
-	Lists

1.3 Definition of terms

Working medium

The medium that flows through the GEMÜ product.

Control medium

The medium whose increasing or decreasing pressure causes the GEMÜ product to be actuated and operated.

Control function

The possible actuation functions of the GEMÜ product.

1.4 Warning notes

Wherever possible, warning notes are organised according to the following scheme:

SIGNAL WORD	
Possible symbol for the specific danger	<p>Type and source of the danger</p> <ul style="list-style-type: none"> ▶ Possible consequences of non-observance. ● Measures for avoiding danger.

Warning notes are always marked with a signal word and sometimes also with a symbol for the specific danger.

The following signal words and danger levels are used:

⚠ DANGER	
	<p>Imminent danger!</p> <ul style="list-style-type: none"> ▶ Non-observance can cause death or severe injury.

⚠ WARNING	
	<p>Potentially dangerous situation!</p> <ul style="list-style-type: none"> ▶ Non-observance can cause death or severe injury.

⚠ CAUTION	
	<p>Potentially dangerous situation!</p> <ul style="list-style-type: none"> ▶ Non-observance can cause moderate to light injury.

NOTICE	
	<p>Potentially dangerous situation!</p> <ul style="list-style-type: none"> ▶ Non-observance can cause damage to property.

The following symbols for the specific dangers can be used within a warning note:

Symbol	Meaning
	Danger of explosion!
	The equipment is subject to pressure.
	Risk of crushing
	Corrosive chemicals!
	Hot plant components!
	Danger from pressure surges or excessive pressure!
	Leakage

2 Safety information

The safety information in this document refers only to an individual product. Potentially dangerous conditions can arise in combination with other plant components, which need to be considered on the basis of a risk analysis. The operator is responsible for the production of the risk analysis and for compliance with the resulting precautionary measures and regional safety regulations.

The document contains fundamental safety information that must be observed during commissioning, operation and maintenance. Non-compliance with these instructions may cause:

- Personal hazard due to electrical, mechanical and chemical effects.
- Hazard to nearby equipment.
- Failure of important functions.
- Hazard to the environment due to the leakage of dangerous substances.

The safety information does not take into account:

- Unexpected incidents and events, which may occur during installation, operation and maintenance.
- Local safety regulations which must be adhered to by the operator and by any additional installation personnel.

Prior to commissioning:

1. Transport and store the product correctly.
2. Do not paint the bolts and plastic parts of the product.
3. Carry out installation and commissioning using trained personnel.
4. Provide adequate training for installation and operating personnel.
5. Ensure that the contents of the document have been fully understood by the responsible personnel.
6. Define the areas of responsibility.
7. Observe the safety data sheets.
8. Observe the safety regulations for the media used.

During operation:

9. Keep this document available at the place of use.
10. Observe the safety information.
11. Operate the product in accordance with this document.
12. Operate the product in accordance with the specifications.
13. Maintain the product correctly.
14. Do not carry out any maintenance work and repairs not described in this document without consulting the manufacturer first.

In cases of uncertainty:

15. Consult the nearest GEMÜ sales office.

3 Product description

3.1 Construction

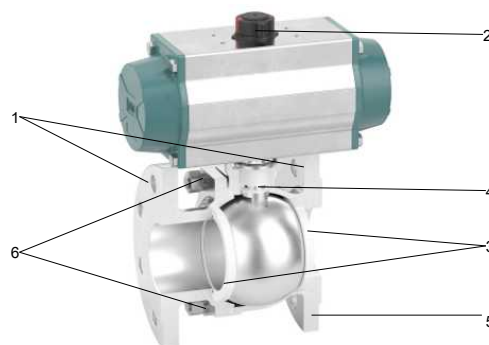

Item	Name	Materials
1	Pipe connections	1.4408 / CF8M
2	Position indicator	
3	Seal	PTFE with glass fibre reinforcement
4	Ball valve shaft	1.4408 / SS316
5	Ball valve body	1.4408 / CF8M
6	Bolt	A2 70

3.2 Pressure-relief hole

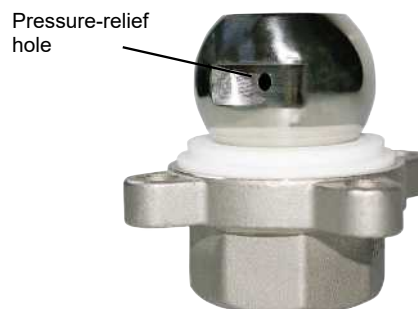

3.3 Control ball

DN 15 to DN 100

Control ball	Code U	Code V	Code W

Note: The control ball cannot be retrofitted to standard 2/2-way bodies at a later date.

3.4 Description

The GEMÜ B4F two-piece 2/2-way metal ball valve is pneumatically operated. The seat seal is made of PTFE reinforced with glass fibre.

3.5 Function

The GEMÜ B4F 2/2-way ball valve is made of metal and is equipped with a low-maintenance aluminium piston actuator. It has an optical position indicator and is available in various designs. The product has two operating states: "Closed" and "Open".

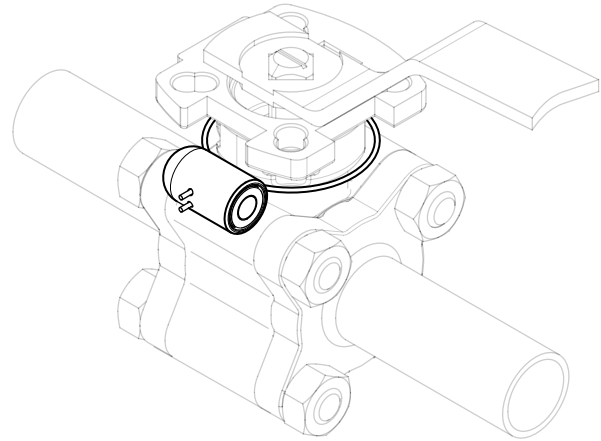

3.6 Product label

The product label is located on the body of the product.

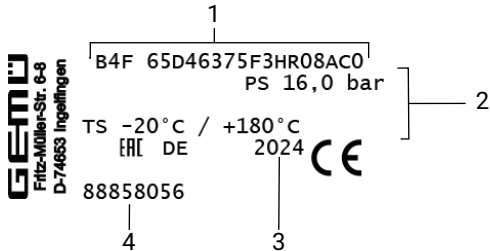

Item	Description
1	Design in accordance with order data
2	Device-specific data
3	Year of manufacture
4	Item number

The operating pressure stated on the product label applies to a media temperature of 20 °C. The product can be used up to the maximum stated media temperature. You can find the pressure/temperature correlation in the technical data.

The control pressure is the minimum required control pressure. NCP (normal control pressure) is for normal applications. NCP (high control pressure) is for more difficult applications.

The month of manufacture is encoded in the traceability number and can be obtained from GEMÜ. The product was manufactured in Germany.

There is a clearly assigned serial number as a QR code on the product.

4 GEMÜ CONEXO

Installing the RFID chip

In the corresponding design with CONEXO, this product has an RFID chip for electronic identification purposes. The position of the RFID chip can be seen below.

5 Correct use

Ball valves are used to isolate media flows.

Only clean, liquid or gaseous media must be used, and the body and seal materials used must be resistant to and suitable for this. Contaminated media and / or applications outside of the pressure and temperature data may lead to damage to the body and, in particular, to the seals on the ball valve.

The "Technical data" chapter describes the permissible pressure / temperature range for these ball valves.

DANGER



Danger of explosion!

- ▶ Risk of severe injury or death
- Only versions that have been approved according to their technical data may be used in potentially explosive environments.

WARNING

Improper use of the product!

- ▶ Risk of severe injury or death
- ▶ Manufacturer liability and guarantee will be void.
- Only use the product in accordance with the operating conditions specified in the contract documentation and in this document.

The product is suitable for installation in piping and for controlling a media flow. The operating conditions according to the technical data apply to the media to be controlled.

The product is controlled via a pneumatic actuator.

The product is not intended for use in potentially explosive areas.

The product must not be exposed to pressure fluctuations. If the product is to be used with pressure fluctuations, please contact GEMÜ.

Due to the design, in the open and closed position, a low volume of medium may be trapped within the ball or between the ball and the body.

Expansion of the medium due to temperature differences, change in state or a chemical response may lead to a high pressure build-up. In order to prevent unacceptable pressure increases, a special version with pressure-relief hole in the ball is available on request for this case.

NOTICE

Build-up of lint!

- ▶ For soft-seated ball valves, due to the relative rotations of the stainless steel ball to the seat seal, slight wear of the PTFE seals must always be anticipated. Despite this, the safety of the ball valve is not affected by any potential build-up of lint and the seal materials are compliant in accordance with FDA directives.

6 Order data

Order codes

The order data provide an overview of standard configurations.

Please check the availability before ordering. Other configurations available on request.

Products ordered with **bold marked ordering options** are so-called preferred series. Depending on the nominal size, these are available more quickly.

1 Type	Code
Ball valve, metal, pneumatically operated, two-piece body, flange, aluminium double-piston actuator, low-maintenance spindle seal and blow-out proof shaft, with anti-static unit	B4F

2 DN	Code
DN 15	15
DN 20	20
DN 25	25
DN 32	32
DN 40	40
DN 50	50
DN 65	65
DN 80	80
DN 100	100
DN 125	125
DN 150	150
DN 200	200

3 Body/ball configuration	Code
2/2-way body	D
2/2-way body, V-ball, 30° (Kv value, see datasheet)	U
2/2-way body, V-ball, 90° (Kv value, see datasheet)	W
2/2-way body, V-ball, 60° (Kv value, see datasheet)	Y

4 Connection type	Code
Flange ANSI class 125/150 RF, up to DN 100 face-to-face dimension FTF EN 558 series 3, ASME/ANSI B16.10 table 1, columns 8 and 9, from DN 125 face-to-face dimension FTF EN 558 series 12,	46
Flange DIN EN 558 series 27 PN40	3E
Flange DIN EN 558 series 27 PN16	3G

5 Ball valve material	Code
1.4408/CF8M (body, connection), 1.4401/SS316 (ball, shaft)	37

6 Seal material	Code
Seat seal = PTFE with glass fibre reinforcement Housing seal = stainless steel with graphite Spindle seal = stainless steel with graphite, Viton O-ring	5F

7 Control function	Code
Normally closed (NC)	1
Normally open (NO)	2
Double acting (DA)	3
Normally closed (NC), actuator mounted across the piping	Q
Double acting (DA), actuator mounted across the piping	T
Normally open (NO), actuator mounted across the piping	U

8 Actuator version	Code
Actuator, pneumatic, double acting, clockwise rotation, GDR0032 F03 S09	HR03AT
Actuator, pneumatic, double acting, clockwise rotation, GDR0050 F03/05 S11	HR05AW
Actuator, pneumatic, double acting, clockwise rotation, GDR0065 F05/07 S14	HR06AP
Actuator, pneumatic, double acting, clockwise rotation, GDR0085 F05/07 S17	HR08AC
Actuator, pneumatic, double acting, clockwise rotation, GDR0100 F07/10 S17	HR10AE

Actuator GEMÜ GDR	Code
Actuator, pneumatic, single acting, clockwise rotation, spring closing, GSR0050 SC5F03/05 S11	GR05SW
Actuator, pneumatic, single acting, clockwise rotation, spring closing, GSR0065 SC5F05/07 S14	GR06SP
Actuator, pneumatic, single acting, clockwise rotation, spring closing, GSR0075 SC5F05/07 S14	GR07SP
Actuator, pneumatic, single acting, clockwise rotation, spring closing, GSR0085 SC5F05/07 S14	GR08SP
Actuator, pneumatic, single acting, clockwise rotation, spring closing, GSR0115 SC5F07/10 S17	GR11SE
Actuator, pneumatic, single acting, clockwise rotation, spring closing, GSR0125 SC5F07/10 S17	GR12SE
Actuator, pneumatic, single acting, clockwise rotation, spring closing, GSR0140 SC5F10/12 S22	GR14SA

Actuator GEMÜ ADA	Code
Actuator, pneumatic, double acting, clockwise rotation, ADA0020U F04 S14S11	BU02AA
Actuator, pneumatic, double acting, clockwise rotation, ADA0040U F05 S14S11	BU04AB
Actuator, pneumatic, double acting, clockwise rotation, ADA0080U F05/07S17S14	BU08AC

8 Actuator version	Code
Actuator, pneumatic, double acting, clockwise rotation, ADA0130U F05/07S17S14	BU13AC
Actuator, pneumatic, double acting, clockwise rotation, ADA0200U F07/10S17S14	BU20AE
Actuator GEMÜ ASR	
Actuator, pneumatic, single acting, clockwise rotation, spring closing, ASR0020US08F04 S14S11	AU02FA
Actuator, pneumatic, single acting, clockwise rotation, spring closing, ASR0040US14F04 S14S11	AU04KA
Actuator, pneumatic, single acting, clockwise rotation, spring closing, ASR0040US14F05 S14S11	AU04KB
Actuator, pneumatic, single acting, clockwise rotation, spring closing, ASR0080US14F05/07S17S14	AU08KC
Actuator, pneumatic, single acting, clockwise rotation, spring closing, ASR0130US14F05/07S17S14	AU13KC
Actuator, pneumatic, single acting, clockwise rotation, spring closing, ASR0300US14F07/10 S22	AU30KD
Actuator, pneumatic, single acting, clockwise rotation, spring closing, ASR0500US14F07/10 S22	AU50KD
Actuator GEMÜ DR	
Actuator, pneumatic, double acting, clockwise rotation, DR0015U F04 S11	DU01AO
Actuator, pneumatic, double acting, clockwise rotation, DR0060U F05/07 S14	DU03AP
Actuator, pneumatic, double acting, clockwise rotation, DR0060U F05/07 S17	DU06AC
Actuator, pneumatic, double acting, clockwise rotation, DR0100U F05/07 S17	DU10AC
Actuator, pneumatic, double acting, clockwise rotation, DR0150U F07/10 S22	DU15AD
Actuator GEMÜ SC	
Actuator, pneumatic, single acting, clockwise rotation, spring closing, SC0015USC8F04 S11	SU01VO
Actuator, pneumatic, single acting, clockwise rotation, spring closing, SC0030U 6F04 S11	SU03KO
Actuator, pneumatic, single acting, clockwise rotation, spring closing, SC0030U 6F05/07 S14	SU03KP
Actuator, pneumatic, single acting, clockwise rotation, spring closing, SC0060U 6F05/07 S14	SU06KP
Actuator, pneumatic, single acting, clockwise rotation, spring closing, SC0100U 6F05/07S17D11	SU10KC
Actuator, pneumatic, single acting, clockwise rotation, spring closing, SC0150U 6F05/07 S17	SU15KC
Actuator, pneumatic, single acting, clockwise rotation, spring closing, SC0220U 6F07/10 S22	SU22KD

8 Actuator version	Code
Actuator, pneumatic, single acting, clockwise rotation, spring closing, SC0450U 6F10/12 S27	SU45KG
9 Actuator particulars	
General industrial version, Aluminium housing, anodised coating 25-35µm, aluminium end caps, powder coated, C-steel shaft + ENP, A2 screws	0
10 Type of design	
Standard	
Media wetted area cleaned to ensure suitability for paint applications, parts sealed in plastic bag	0101
Media wetted parts cleaned for high purity media and packed in plastic bag	0104
Valve free of oil and grease, media wetted area cleaned and packed in PE bag	0107
Thermal separation between actuator and valve body via mounting kit	5222
Thermal separation between actuator and valve body by mounting kit, mounting kit and mounting parts in stainless steel	5227
K-no. SF5, K-no. 5222, SF5 - Ra max. 0.51 µm (20 µin.) electropolished internal/external, 5222 - Thermal separation via mounting kit	7143
11 CONEXO	
Without	
Integrated RFID chip for electronic identification and traceability	C

Order example

Ordering option	Code	Description
1 Type	B4F	Ball valve, metal, pneumatically operated, two-piece body, flange, aluminium double piston actuator, low-maintenance spindle seal and blow-out proof shaft, with anti-static unit
2 DN	15	DN 15
3 Body/ball configuration	D	2/2-way body
4 Connection type	3E	Flange DIN EN 558 series 27 PN40
5 Ball valve material	37	1.4408 / CF8M (body, connection), 1.4401 / SS316 (ball, shaft)
6 Seal material	5F	Seat seal = PTFE with glass fibre reinforcement Body seal = stainless steel with graphite Spindle seal = stainless steel with graphite, Viton O-ring
7 Control function	3	Double acting (DA)
8 Actuator version	BU02AA	Actuator, pneumatic, double acting, clockwise rotation, ADA0020U F04 S14S11
9 Actuator particulars	0	General industrial version, Aluminium housing, anodised coating 25-35µm, aluminium end caps, powder coated, C-steel shaft + ENP, A2 screws
10 Type of design		Standard
11 CONEXO		Without

7 Technical data

7.1 Medium

Working medium: Corrosive, inert, gaseous and liquid media and steam which have no negative impact on the physical and chemical properties of the body and seal material.

7.2 Temperature

Media temperature: -40 – 220 °C
For media temperatures > 100 °C, we recommend using a mounting kit with adapter between the ball valve and the actuator.

Ambient temperature: -20 – 60 °C

Storage temperature: -60 – 60 °C

7.3 Pressure

Operating pressure: 0 – 40 bar

Vacuum: Can be used up to a vacuum of 50 mbar (absolute)
These values apply to room temperature and air. The values may deviate for other media and other temperatures.

Pressure/temperature diagram:

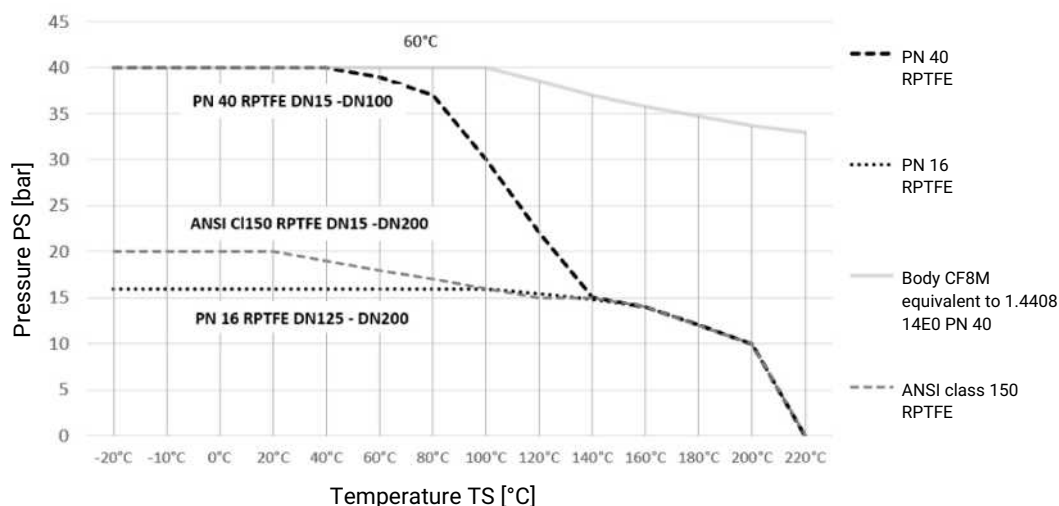

Pressure/temperature data in accordance with diagram refers to static operating conditions. Strongly fluctuating or fast-changing parameters can lead to a reduction of the service life. Special applications must be talked through with your technical contact person in advance.

Leakage rate: Leakage rate according to ANSI FCI70 – B16.104
Leakage rate according to EN12266, 6 bar air, leakage rate A

Cv values:**Standard ball (code D)**

DN	NPS	Kv values
15	1/2"	26
20	3/4"	47
25	1"	82
32	1¼"	146
40	1½"	231
50	2"	403
65	2½"	668
80	3"	985
100	4"	1799
125	5"	2999
150	6"	4284
200	8"	8141

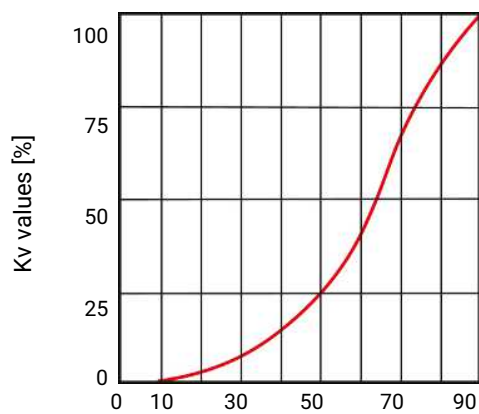
Kv values in m³/h**Diagrammatic view**

Opening angle of the standard ball [°]

V-ball 30° (code U)

DN	NPS	Opening angle										
		0	15%	20%	30%	40%	50%	60%	70%	80%	90%	100%
15	1/2"	0	0.085	0.085	0.170	0.255	0.425	0.680	0.935	1.360	1.870	2.210
20	3/4"	0	0.085	0.170	0.425	0.595	0.935	1.530	2.040	2.805	3.825	4.590
25	1"	0	0.085	0.255	0.680	1.105	1.955	2.975	4.335	5.961	8.128	8.500
32	1¼"	0	0.170	0.340	0.935	1.700	3.145	4.675	6.800	8.500	11.050	12.750
40	1½"	0	0.255	0.510	1.360	2.550	4.250	6.375	9.350	11.900	14.450	17.000
50	2"	0	0.340	1.020	3.230	5.100	8.500	12.75	19.550	26.350	36.550	51.000
65	2½"	0	0.340	0.850	3.400	6.800	10.200	15.300	23.800	31.450	52.70	63.750
80	3"	0	0.425	1.020	3.400	6.800	11.900	19.550	28.050	39.100	55.250	69.700
100	4"	0	0.510	1.700	5.100	12.750	24.650	40.800	60.350	85.000	110.50	135.20

Kv values in m³/h

Cv values:

V-ball 60° (code Y)

DN	NPS	Opening angle										
		0	15%	20%	30%	40%	50%	60%	70%	80%	90%	100%
15	1/2"	0	0.085	0.085	0.255	0.425	0.765	1.190	1.700	2.805	3.740	5.100
20	3/4"	0	0.085	0.170	0.595	0.850	1.445	2.380	3.400	5.525	7.650	10.200
25	1"	0	0.170	0.340	0.935	1.530	2.890	4.505	6.715	10.46	13.010	17.850
32	1¼"	0	0.170	0.510	1.530	2.550	4.675	8.075	10.880	16.15	22.100	33.150
40	1½"	0	0.340	0.680	2.125	3.400	6.800	11.050	16.150	22.95	34.000	44.200
50	2"	0	0.340	1.275	3.910	7.650	14.030	22.950	33.150	46.75	70.550	93.500
65	2½"	0	0.340	1.275	4.250	8.500	17.850	28.900	45.050	63.75	87.550	127.50
80	3"	0	0.425	2.125	5.100	11.900	21.250	34.000	55.250	77.35	108.80	140.30
100	4"	0	0.595	2.550	9.350	21.250	34.000	50.150	76.500	119.9	180.20	302.60

Kv values in m³/h

V-ball 90° (code W)

DN	NPS	Opening angle										
		0	15%	20%	30%	40%	50%	60%	70%	80%	90%	100%
15	1/2"	0	0.085	0.170	0.340	0.510	0.765	1.275	1.870	3.230	4.590	5.865
20	3/4"	0	0.170	0.340	0.680	1.020	1.700	2.635	3.910	6.800	9.605	11.900
25	1"	0	0.170	0.510	1.530	2.890	4.335	6.885	9.690	13.600	17.850	24.650
32	1¼"	0	0.255	0.680	1.700	4.250	6.800	11.900	16.150	23.800	33.150	46.750
40	1½"	0	0.425	0.765	2.975	5.950	11.050	17.000	26.350	35.700	53.550	66.300
50	2"	0	0.595	1.700	5.100	10.200	18.700	29.750	38.250	59.500	89.250	114.80
65	2½"	0	0.425	1.445	5.950	11.900	23.800	40.800	59.500	90.100	136.00	185.30
80	3"	0	0.595	2.975	6.800	15.300	29.750	51.000	76.500	114.80	174.30	263.50
100	4"	0	0.850	2.975	13.600	34.000	63.750	106.30	161.50	250.80	375.70	569.50

Kv values in m³/h

Pressure rating:

DN	Flange		
	46	3E	3G
15	Class 150	PN40	-
20	Class 150	PN40	-
25	Class 150	PN40	-
32	Class 150	PN40	-
40	Class 150	PN40	-
50	Class 150	PN40	-
65	Class 150	PN40	-
80	Class 150	PN40	-
100	Class 150	PN40	-
125	Class 150	-	PN16
150	Class 150	-	PN16
200	Class 150	-	PN16

* on request

Connection type	Code
Flange ANSI class 125/150 RF, up to DN 100 face-to-face dimension FTF EN 558 series 3, ASME/ANSI B16.10 table 1, columns 8 and 9, from DN 125 face-to-face dimension FTF EN 558 series 12,	46
Flange DIN EN 558 series 27 PN40	3E
Flange DIN EN 558 series 27 PN16	3G

Control pressure:

6 to 8 bar

7.4 Product conformity

Machinery Directive:	2006/42/EC
Fire Safe:	API 607 and DIN EN ISO 10497
Pressure Equipment Directive:	ASME GEMÜ B31.3 (DN 15–200) 2014/68/EU
Explosion protection:	Based on ATEX (2014/34/EU), order code special version X
ATEX marking:	The ATEX marking of the product depends on the respective product configuration with valve body and actuator. It can be found in the product-specific ATEX documentation and the ATEX type plate.

7.5 Mechanical data

90° travel:	GEMÜ GDR/GSR: ±5° adjustable (85° - 95°) GEMÜ ADA /ASR: ±5° adjustable (85° - 95°) GEMÜ DR /SC: 20° adjustable (75° - 95°)
--------------------	--

Weight: Ball valve

DN	NPS	Connection code 46	Connection code 3E, 3G
15	1/2"	1.4	2.2
20	3/4"	1.75	2.8
25	1"	2.75	3.7
32	1¼"	3.45	5.3
40	1½"	5.1	6.4
50	2"	7.45	8.9
65	2½"	11.65	14.8
80	3"	15.55	19.9
100	4"	26.65	27
125	5"	41.3	43
150	6"	61.7	61
200	8"	127.55	120.6

Weights in kg

Actuator type GDR/GSR

Type	GDR Double act- ing	GSR Single acting
0032	0.5	-
0050	1.1	1.2
0065	1.5	1.8
0075	2.6	3.2
0085	3.4	4.3
0100	5.1	6.6
0115	8.0	10.6
0125	10.0	13.4
0140	11.0	17.2

Weights in kg

Weight:**Actuator type ADA/ASR**

Type	ADA Double act- ing	ASR Single acting
0020U	1.4	1.5
0040U	2.1	2.3
0080U	3.0	3.7
0130U	3.8	4.8
0200U	5.6	7.3
0300U	8.5	10.8
0500U	11.2	15.4

Weights in kg

Actuator type DR/SC

Type	DR Double act- ing	SC Single acting
0015U	1.0	1.1
0030U	1.6	1.7
0060U	2.7	3.1
0100U	3.7	4.3
0150U	5.2	6.1
0220U	8.0	9.3
0300U	9.8	12.0
0450U	14.0	17.0

Weights in kg

Torques:

DN	NPS	Breakaway torque
15	1/2"	14
20	3/4"	14
25	1"	20
32	1¼"	24
40	1½"	36
50	2"	53
65	2½"	91
80	3"	120
100	4"	174
125	5"	264
150	6"	368
200	8"	552

Torques in Nm

A safety factor of 1.2 is included

With dry, non-lubricating media the breakaway torque may be increased.

Valid for clean, non-particulate and oil-free media (water, alcohol, etc.) or gas or saturated steam (clean and wet). Seal, PTFE with glass fibre reinforcement.

8 Dimensions

8.1 Actuator dimensions

Note on actuator mounting:

Standard mounting orientation – actuator positioned in-line with piping

Only with flanged connections the actuator is mounted across the piping

8.1.1 Type GDR/GSR

8.1.1.1 Type G0032

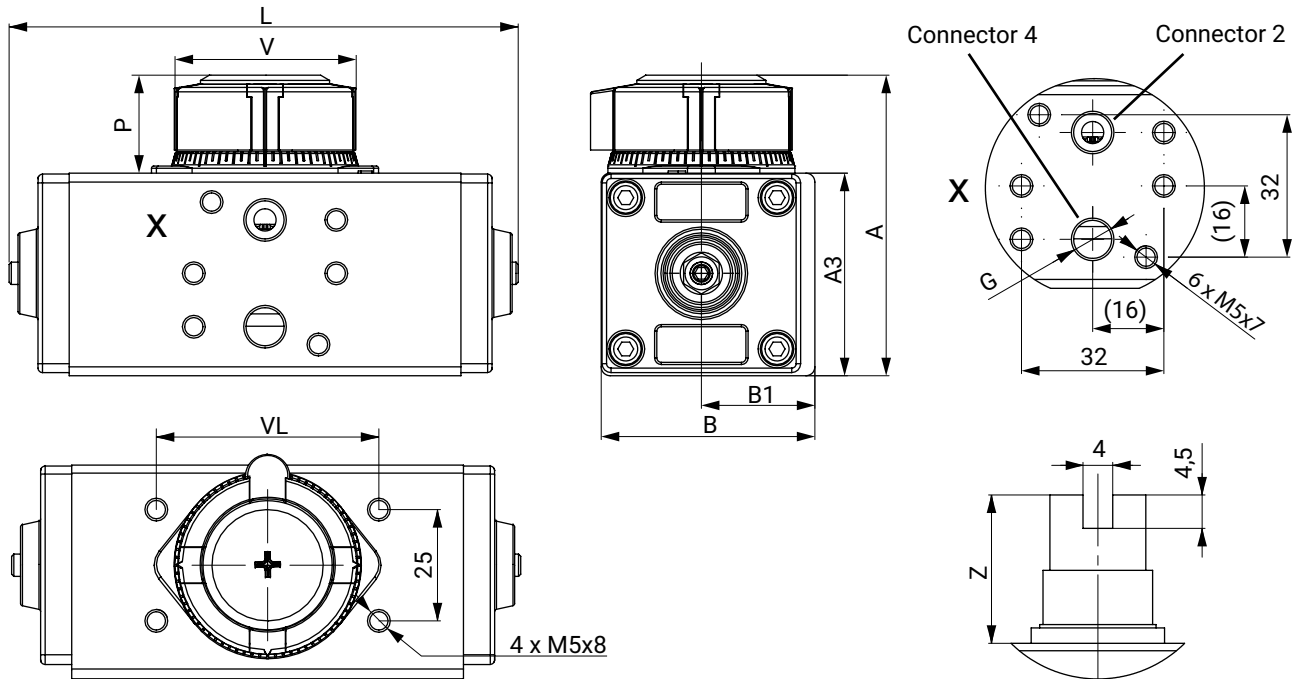

The control air connector (view X) for GDR0032 is not compatible for direct mounting with a Namur pilot valve, or a throttle of type 8500/8506.

Provide the control air connector with external thread fittings and a compressed air hose

Type	A	A3	B	B1	V	G	P	VL	Z	L
G0032	67.5	45.5	49.0	26.5	40.0	G1/8"	22.0	50.0	20.0	115.0

Dimensions in mm

8.1.1.2 Type G0050 – G0180

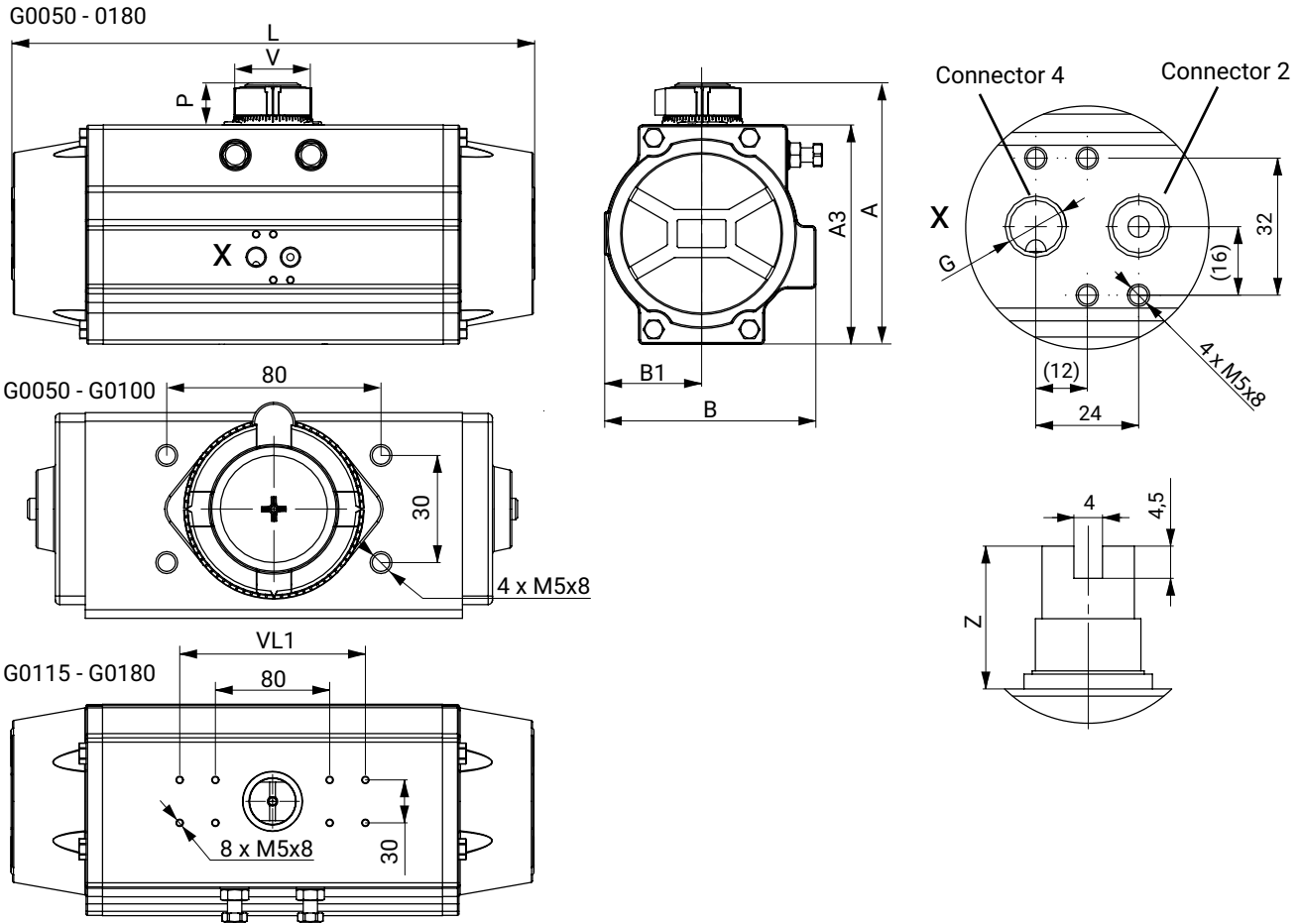

Type	A	A3	B	B1	V	G	P	VL	Z	L	VL1
G0050	92.0	70.0	71.0	30.0	40.0	G1/8"	22.0	80.0	20.0	141.0	-
G0065	102.5	80.5	80.5	35.5	40.0	G1/8"	22.0	80.0	20.0	162.0	-
G0075	119.0	97.0	94.5	42.0	40.0	G1/8"	22.0	80.0	20.0	208.0	-
G0085	130.5	108.5	106.0	47.5	40.0	G1/8"	22.0	80.0	20.0	237.0	-
G0100	143.5	121.5	123.0	55.0	40.0	G1/4"	22.0	80.0	20.0	271.5	-
G0115	174.0	142.0	137.0	64.0	65.0	G1/4"	32.0	80.0	30.0	337.0	130.0
G0125	185.5	153.5	148.0	68.0	65.0	G1/4"	32.0	80.0	30.0	366.0	130.0
G0140	207.9	175.9	164.0	76.5	65.0	G1/4"	32.0	80.0	30.0	428.5	130.0
G0160	225.0	193.0	188.0	88.0	65.0	G1/4"	32.0	80.0	30.0	512.0	130.0
G0180	251.0	219.0	212.5	96.5	65.0	G1/4"	32.0	80.0	30.0	573.0	130.0

Dimensions in mm

8.1.2 Type ADA/ASR

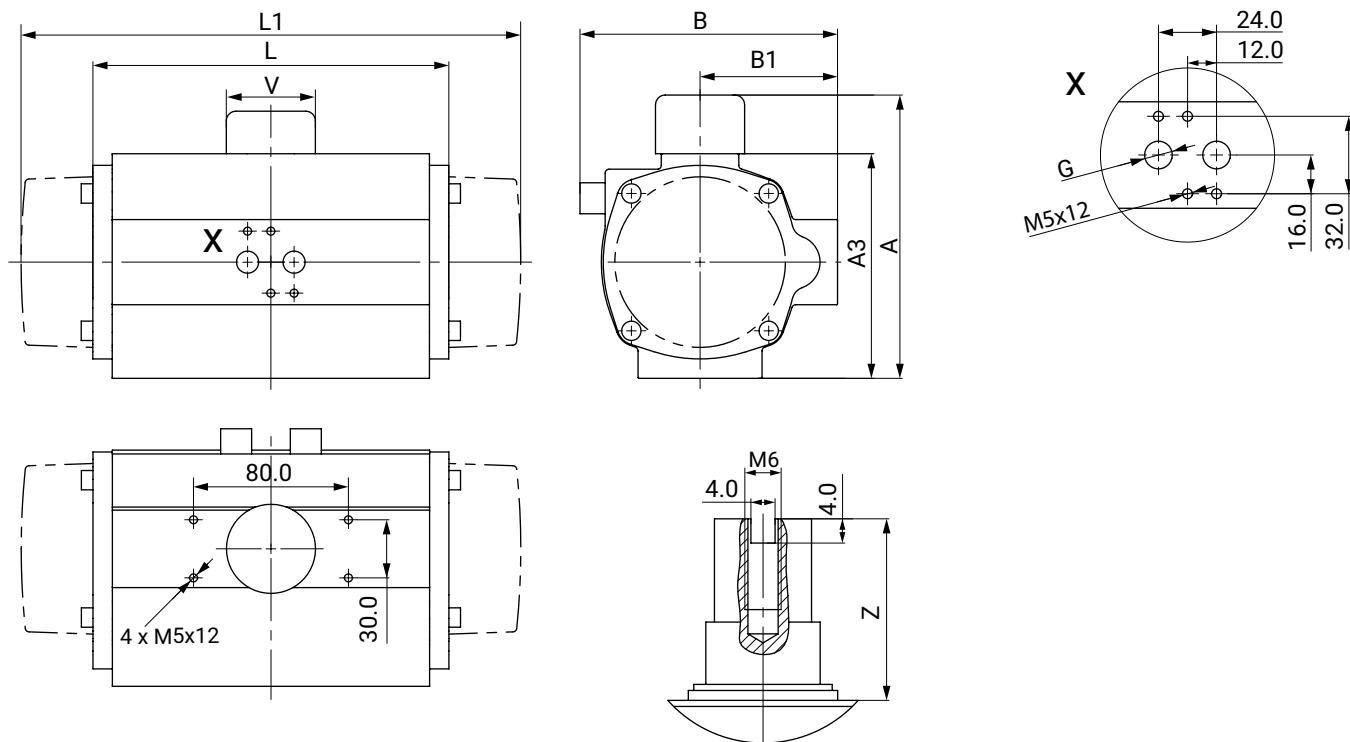

Type	A	A3	B	B1	G	L	L1	V	Z
0020U	96.0	66.0	76.0	48.0	G1/4"	145.0	163.0	40.0	30.0
0040U	115.0	85.0	91.0	56.0	G1/4"	158.0	195.0	40.0	30.0
0080U	137.0	107.0	111.0	66.0	G1/4"	177.0	217.0	40.0	30.0
0130U	147.0	117.0	122.0	71.0	G1/4"	196.0	258.0	40.0	30.0
0200U	165.0	135.0	135.5	78.0	G1/4"	225.0	299.0	40.0	30.0
0300U	182.0	152.0	152.5	86.0	G1/4"	273.0	348.5	40.0	30.0
0500U	199.0	169.0	173.0	96.0	G1/4"	304.0	397.0	40.0	30.0

Dimensions in mm

8.1.3 Type DR/SC

Actuator dimensions

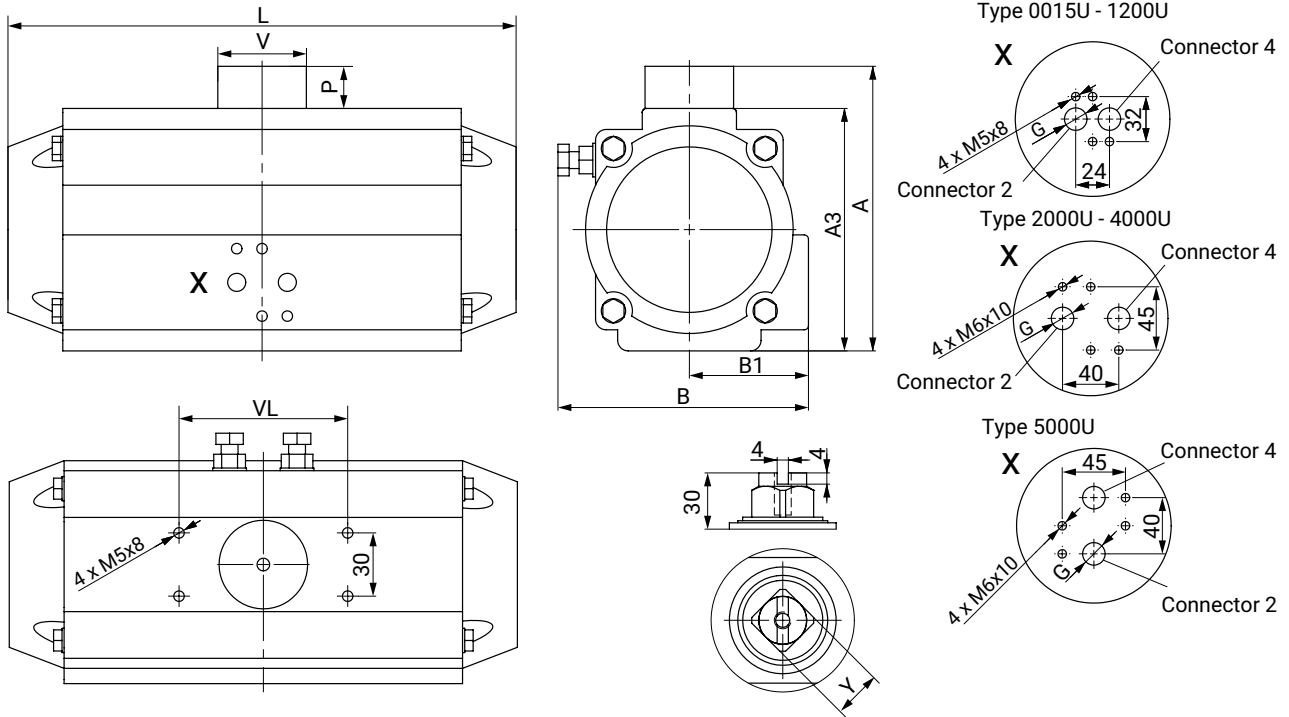

Type	A	A3	B	B1	V	VL	G	P	L	Y
0015U	89.0	69.0	72.0	43.0	42.0	80.0	G1/8"	20.0	136.0	11.0
0030U	105.0	85.0	84.5	48.5	42.0	80.0	G1/8"	20.0	153.5	11.0
0060U	122.0	102.0	93.0	50.5	42.0	80.0	G1/8"	20.0	203.5	17.0
0100U	135.0	115.0	106.0	56.5	42.0	80.0	G1/8"	20.0	241.0	17.0
0150U	147.0	127.0	118.5	63.0	42.0	80.0	G1/4"	20.0	259.0	17.0
0220U	175.0	145.0	136.0	72.0	58.0	80.0	G1/4"	30.0	304.0	27.0
0300U	187.0	157.0	146.5	77.0	58.0	80.0	G1/4"	30.0	333.0	27.0
0450U	207.0	177.0	166.0	86.0	67.5	80.0	G1/4"	30.0	394.5	27.0

Dimensions in mm

8.2 Ball valve

8.2.1 Actuator flange

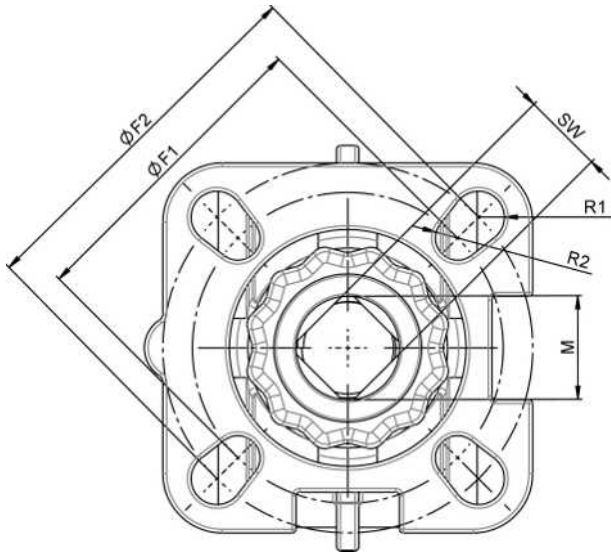

DN	G	F1	ISO 5211	R1	F2	ISO 5211	R2	SW	M	
15	1/2"	36	F03	3	42	F04	3	9	M12	ANSI/PN
20	3/4"	36	F03	3	42	F04	3	9	M12	ANSI/PN
25	1"	42	F04	3	50	F05	3.5	11	M14	ANSI/PN
32	1 1/4"	42	F04	3	50	F05	3.5	11	M14	ANSI/PN
40	1 1/2"	50	F05	3.5	70	F07	4.5	14	M18	ANSI/PN
50	2"	50	F05	3.5	70	F07	4.5	14	M18	ANSI/PN
65	2 1/2"	70	F07	5	102	F10	4.5	17	M22	PN40
80	3"	70	F07	5	102	F10	6	17	M22	PN40
100	4"	102	F10	5	125	F12	6	22	M27	PN40
65	2 1/2"	50	F05	3.5	70	F07	4.5	14	M18	ANSI
80	3"	70	F07	5	102	F10	4.5	17	M22	ANSI
100	4"	70	F07	5	102	F10	6	17	M22	ANSI
125	5"	102	F10	5	125	F12	6	27	M34	ANSI
150	6"	102	F10	5	125	F12	6	27	M34	ANSI
200	8"	-	-	5	125	F12	6	27	M34	ANSI
100	4"	70	F07	5	102	F10	4.5	17	M22	PN16
125	5"	102	F10	5	125	F12	6	22	M27	PN16
150	6"	102	F10	5	125	F12	6	22	M27	PN16
200	8"	-	-	5	125	F12	6	27	M34	PN16

Dimensions in mm

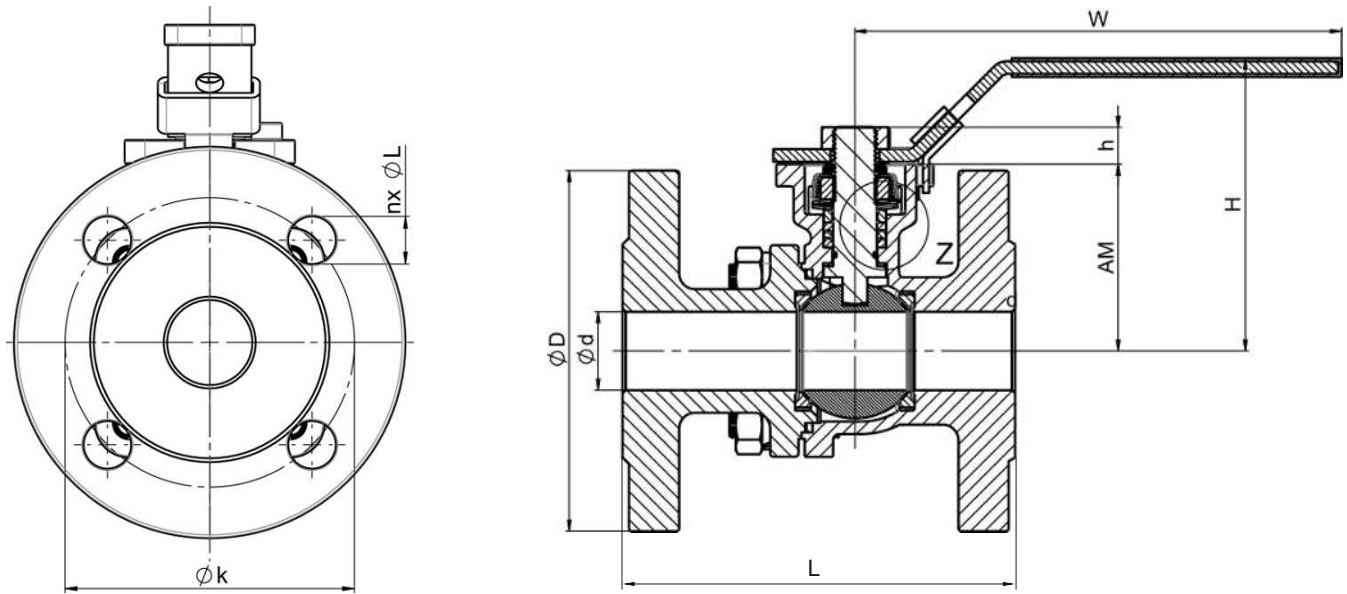
8.2.2 Flange (connection code 3E, 3G)

DN	Conne- tion code	Ød	ØD	h	Øk	n x ØL	W	H	AM	L
15	3E	15.0	95.0	10	65.0	4 x 14.0	125	80	48	115
20	3E	20.0	105.0	10	75.0	4 x 14.0	125	84	54	120
25	3E	25.0	115.0	12	85.0	4 x 14.0	155	93	59	125
32	3E	32.0	140.0	12	100.0	4 x 18.0	155	105	71	130
40	3E	38.0	150.0	15	110.0	4 x 18.0	195	122	78	140
50	3E	50.0	165.0	15	125.0	4 x 18.0	195	129	85	150
65	3E	65.0	185.0	17	145.0	8 x 18.0	257	162	107	170
80	3E	76.0	200.0	18	160.0	8 x 18.0	221	173	117	180
100	3E	100.0	235.0	23	190.0	8 x 22.0	254	203	150	190
125	3G	125	270	23	210	8 x 18.0	430	248	180	325
150	3G	150	300	23	240	8 x 22.0	430	266	198	350
200	3G	200	375	31	340	12 x 22.0	700	329	252	400

8.2.3 Flange (connection code 46)

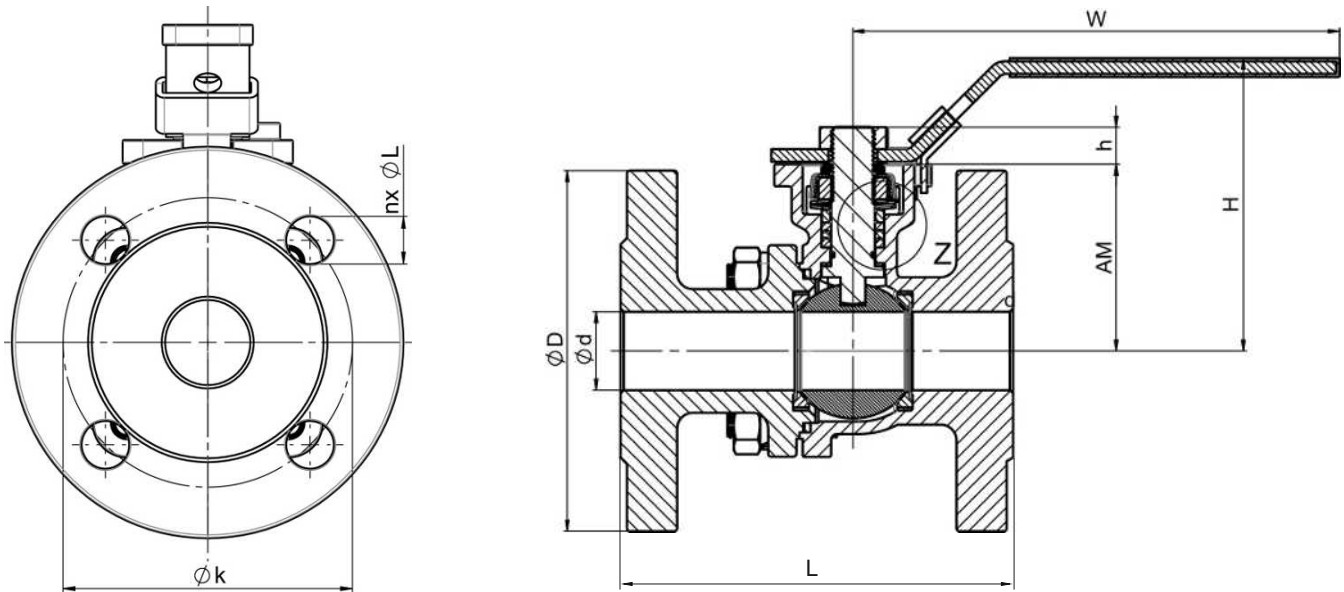

DN	Conne- tion code	ϕd	ϕD	h	ϕk	n x ϕL	W	H	AM	L
15	46	15.0	95.0	10	65.0	4 x 16.0	125	80	48	108
20	46	20.0	105.0	10	75.0	4 x 16.0	125	84	54	117
25	46	25.0	115.0	12	85.0	4 x 16.0	155	93	59	127
32	46	32.0	140.0	12	100.0	4 x 16.0	155	105	71	140
40	46	38.0	150.0	15	110.0	4 x 16.0	195	122	78	165
50	46	50.0	165.0	15	125.0	4 x 19.0	195	129	85	178
65	46	65.0	185.0	17	145.0	4 x 19.0	257	162	107	190
80	46	76.0	200.0	18	160.0	4 x 19.0	221	173	117	203
100	46	100.0	235.0	23	190.0	8 x 19.0	254	203	150	229
125	46	125	255	23	216	8 x 19.0	430	248	180	356
150	46	150	280	23	252	8 x 19.0	430	266	198	394
200	46	200	345	31	298	8 x 19.0	700	329	252	457

9 Manufacturer's information

9.1 Delivery

- Check that all parts are present and check for any damage immediately upon receipt.

The product's performance is tested at the factory. The scope of delivery is apparent from the dispatch documents and the design from the order number.

9.2 Packaging

The product is packaged in a cardboard box which can be recycled as paper.

9.3 Transport











1. Only transport the product by suitable means. Do not drop. Handle carefully.
2. Note the weight of the product. If necessary, use suitable lifting equipment.
3. Dispose of transport packing materials according to relevant local or national disposal regulations/environmental protection laws after installation.

9.4 Storage

1. Store the product free from dust and moisture in its original packaging.
2. Avoid UV rays and direct sunlight.
3. Do not exceed the maximum storage temperature (see chapter "Technical data").
4. Do not store solvents, chemicals, acids, fuels or similar fluids in the same room as GEMÜ products and their spare parts.
5. Store the ball valves in the "open" position.

10 Installation in piping

10.1 Preparing for installation

 DANGER	
	<p>The equipment is subject to pressure.</p> <ul style="list-style-type: none"> ▶ Risk of severe injury or death ● Depressurize the plant. ● Completely drain the plant.
 WARNING	
	<p>Risk of crushing</p> <ul style="list-style-type: none"> ▶ Serious injuries ● Do not reach into the valve. ● Ensure that it is not possible to reach into the valve when using it as an end-of-line valve.
 WARNING	
	<p>Corrosive chemicals!</p> <ul style="list-style-type: none"> ▶ Risk of caustic burns ● Wear appropriate protective gear. ● Completely drain the plant.
 CAUTION	
	<p>Hot plant components!</p> <ul style="list-style-type: none"> ▶ Risk of burns ● Only work on plant that has cooled down.
 CAUTION	
<p>Exceeding the maximum permissible pressure.</p> <ul style="list-style-type: none"> ▶ Damage to the product ● Provide precautionary measures against exceeding the maximum permitted pressures caused by pressure surges (water hammer). 	
 CAUTION	
<p>Use as step.</p> <ul style="list-style-type: none"> ▶ Damage to the product ▶ Risk of slipping-off ● Choose the installation location so that the product cannot be used as a foothold. ● Do not use the product as a step or a foothold. 	
NOTICE	
<p>Suitability of the product!</p> <ul style="list-style-type: none"> ▶ The product must be appropriate for the piping system operating conditions (medium, medium concentration, temperature and pressure) and the prevailing ambient conditions. 	

NOTICE

Tools!

- ▶ The tools required for installation and assembly are not included in the scope of delivery.
 - Use appropriate, functional and safe tools.
1. Ensure the product is suitable for the relevant application.
 2. Check the technical data of the product and the materials.
 3. Keep appropriate tools ready.
 4. Wear appropriate protective gear as specified in the plant operator's guidelines.
 5. Observe appropriate regulations for connections.
 6. Have installation work carried out by trained personnel.
 7. Shut off plant or plant component.
 8. Secure the plant or plant component against recommissioning.
 9. Depressurize the plant or plant component.
 10. Completely drain the plant or plant component and allow it to cool down until the temperature is below the media vaporization temperature and cannot cause scalding.
 11. Correctly decontaminate, rinse and ventilate the plant or plant component.
 12. Lay piping so that the product is protected against transverse and bending forces, and also vibrations and tension.
 13. Only install the product between matching aligned pipes (see chapters below).
 14. Flow direction and installation position are optional.

10.2 Installation with flanged connections

NOTICE

- ▶ Observe valid standards for mounting flanges!

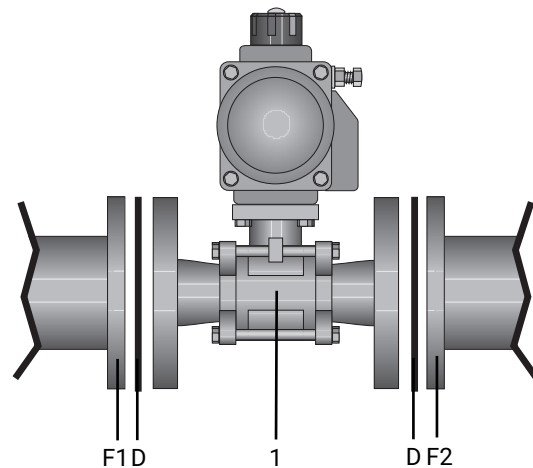

1. Ensure sealing surfaces on the mating flanges are clean and undamaged.
2. Only use connector elements made of approved materials!
3. Install the ball valve in the state it is delivered.
4. Carefully align the ball valve body **1** centrally between the pipes with flanges (**F1** and **F2**).
5. Centre the seals **D** accurately. Seals are not included in the scope of delivery.
6. Connect the ball valve flange and the piping flange using appropriate sealing material and matching bolting. Sealing material and bolts are not included in the scope of delivery.

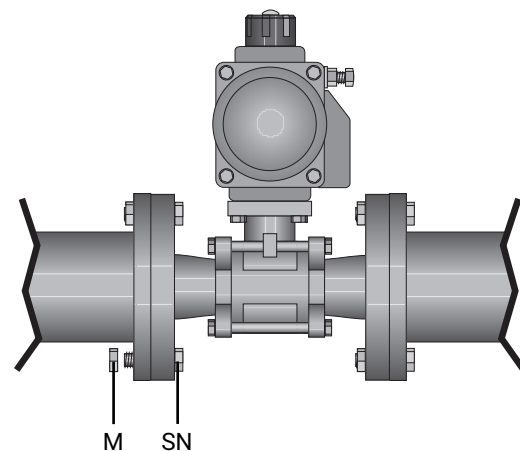

7. Insert bolts **SN** in all holes in the flange.
8. Slightly tighten the bolts **SN** and nuts **M** diagonally.

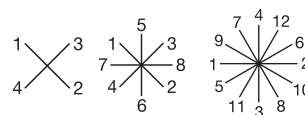

9. Check the alignment of the piping.
10. Tighten the nuts **M** diagonally.

Observe appropriate regulations for connections!

10.3 After the installation

- Re-attach or reactivate all safety and protective devices.

11 Pneumatic connection

11.1 Control functions

The following control functions are available:

Control function 1, actuator aligned parallel to the piping, control function Q, actuator aligned across the piping normally closed (NC)

Ball valve resting position: closed by spring force. Activation of the actuator (connector 2) opens the ball valve. When the actuator is vented, the ball valve is closed by spring force.

Control function 2, actuator aligned parallel to the piping, control function U, actuator aligned across the piping normally open (NO)

Ball valve resting position: opened by spring force. Activation of the actuator (connector 4) closes the ball valve. When the actuator is vented, the ball valve is opened by spring force.

Control function 3, actuator aligned parallel to the piping, control function T, actuator aligned across the piping double acting (DA)

Ball valve resting position: undefined. The ball valve is opened and closed by activating the respective control medium connectors (connector 2: open / connector 4: close).

Control functions	Connectors	
	2	4
1 (NC), Q (NC)	+	-
2 (NO), U (NO)	-	+
3 (DA), T (DA)	+	+

+ = available / - = not available
(for connectors 2 / 4 see picture in chapter "Connecting the control medium")

11.2 Optical position indicator

Control function 1, 2, 3

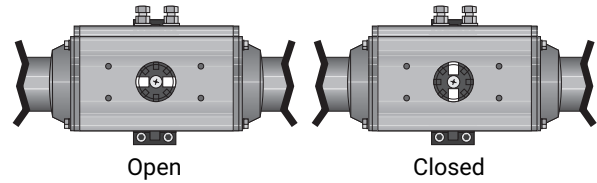

Control function Q, U, T

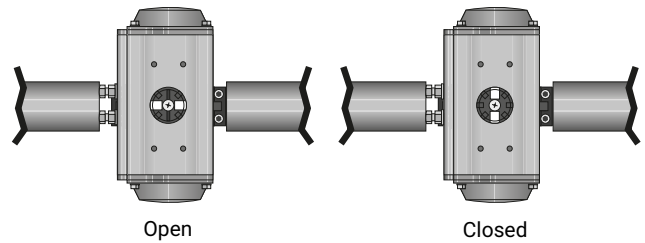

11.3 Connecting the control medium

1. Use suitable connectors.
2. Connect the control medium lines tension-free and without any bends or knots.

Thread size of the control medium connectors: G1/4

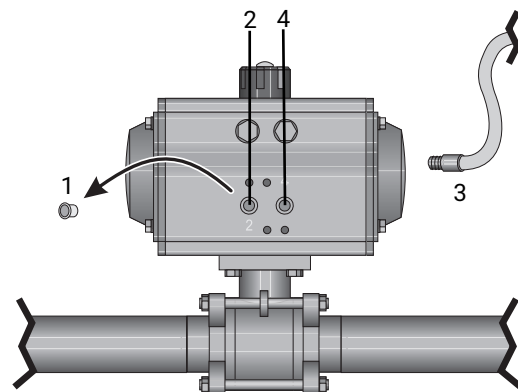

3. Remove the protection cap 1.
4. Screw the control medium line 3 into control medium connector 2.
5. If appropriate, screw the second control medium line into control medium connector 4.

Control function	Connectors
1 Normally closed (NC)	2: Control medium (open)
2 Normally open (NO)	4: Control medium (close)
3 Double acting (DA)	2: Control medium (open) 4: Control medium (close)

For connectors T 2 / 4 see picture above

12 Setting the end positions

The end positions can be set by $\pm 20^\circ$ ($+5^\circ/-15^\circ$).

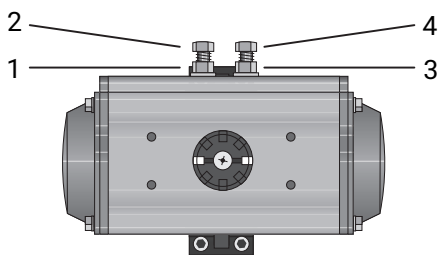

Setting the 0° end position:

1. Move the ball valve to the closed position.
2. Loosen the lock nut **1**.
3. Set the end position via screw **2**.
4. Tighten the lock nut **1**.

Setting the 90° end position:

5. Move the ball valve to the open position.
6. Loosen the lock nut **3**.
7. Set the end position via screw **4**.
8. Tighten the lock nut **3**.

13 Commissioning

DANGER



Danger from pressure surges or excessive pressure!

- ▶ Serious injury or death due to penetration of pressurized media
- Ensure that the valve can be dismantled for maintenance purposes.

WARNING



Corrosive chemicals!

- ▶ Risk of caustic burns
- Wear appropriate protective gear.
- Completely drain the plant.

CAUTION



Leakage

- ▶ Emission of dangerous materials
- Provide for precautionary measures against exceeding the maximum permissible pressure that may be caused by pressure surges (water hammer).

1. Check the tightness and the function of the product (close and reopen the product).
2. Flush the piping system of new plant and following repair work (the product must be fully open).
 - ⇒ Harmful foreign matter has been removed.
 - ⇒ The product is ready for use.
3. Commission the product.

14 Operation

Operate the product according to the control function (see also chapter "Pneumatic connection").

15 Troubleshooting

Error	Possible cause	Troubleshooting
The product does not open or does not open fully	The actuator is providing a breakaway torque that is too low	Check the control pressure supply
	Foreign matter in the product	Remove and clean the product
The product does not close or does not close fully	The actuator is providing a breakaway torque that is too low	Check the control pressure supply
	Foreign matter in the product	Remove and clean the product
The product is leaking between actuator and valve body	Faulty product	Check the product for potential damage, replace the product if necessary
	Seals faulty	Replace seals
Connection between valve body and piping leaking	Incorrect installation	Check installation of valve body in piping
	Flange bolting loose/thread leaking	Retighten flange bolting / reseal threads
	Flange seals faulty	Replace flange seals
Valve body leaking	Valve body leaking or corroded	Check valve body for damage, replace valve body if necessary

16 Inspection/maintenance

⚠ WARNING

The equipment is subject to pressure!

- ▶ Risk of severe injury or death
- Depressurize the plant.
- Completely drain the plant.

⚠ CAUTION



Hot plant components!

- ▶ Risk of burns
- Only work on plant that has cooled down.

⚠ CAUTION

- Servicing and maintenance work must only be performed by trained personnel.
- Do not extend hand lever. GEMÜ shall assume no liability whatsoever for damages caused by improper handling or third-party actions.
- In case of doubt, contact GEMÜ prior to commissioning.

1. Use appropriate protective gear as specified in plant operator's guidelines.
2. Shut off plant or plant component.
3. Secure against recommissioning.
4. Depressurize the plant or plant component.

Ball valves are maintenance-free. No lubrication or routine maintenance of the ball valve shaft is required. The shaft is guided through a PTFE gland packing in the ball valve body. The shaft seal is pretensioned and self-adjusting. However, the operator must carry out regular visual examinations of the ball valves, dependent on the operating conditions and the potential danger in order to prevent leakage and damage.

If there is a leakage at the spindle nut, this can generally be rectified by retightening the spindle nut. However, overtightening the spindle nut must be avoided.

Usually, retightening by between 30° and 60° will be sufficient to rectify the leakage.

16.1 General information regarding actuator replacement

NOTICE

The following tools are required for actuator replacement:

- Allen key

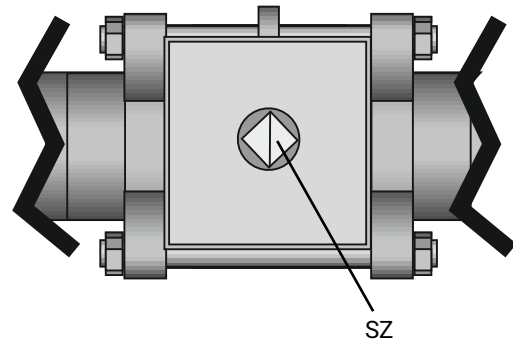

1. Check the position of the ball indicated by the groove **SZ** and compare with position indicator, rotate ball valve to correct position if necessary.

⇒ Groove transverse to piping direction:
Ball valve closed.

⇒ Groove in piping direction:
Ball valve open.

16.1.1 Replacing the actuator

1. Depressurize the control medium.
2. Unscrew the control medium line(s) on the actuator.

16.1.1.1 Removing the actuator

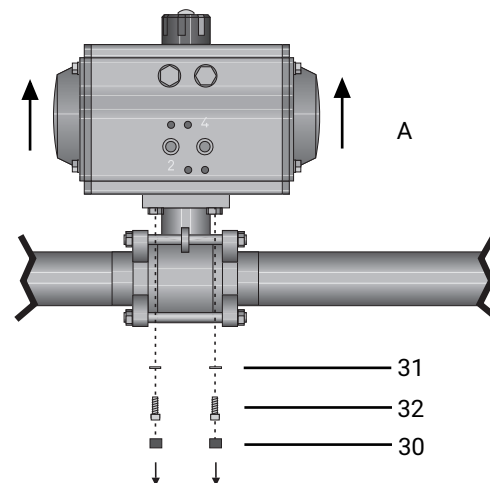

1. Remove the protective caps **30**.
2. Unscrew the hexagon screws **32**.
3. Do not lose the washers **31**.
4. The actuator **A** can be removed from the ball valve body.

16.1.1.2 Mounting the actuator

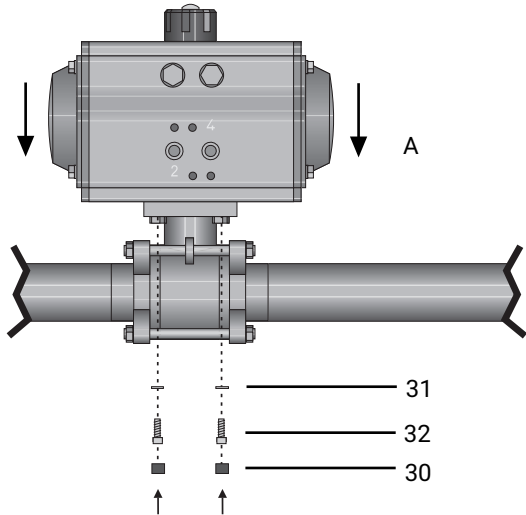

1. Push the new actuator **A** onto the ball valve body.
2. Turn the actuator until the hexagon screws **32** can be inserted.
3. Tighten the hexagon screws **32** with their washers **31** until hand tight.
4. Diagonally tighten the hexagon screws **32** evenly until they are hand tight.
5. Put the protective caps **30** back on.

16.2 Spare parts

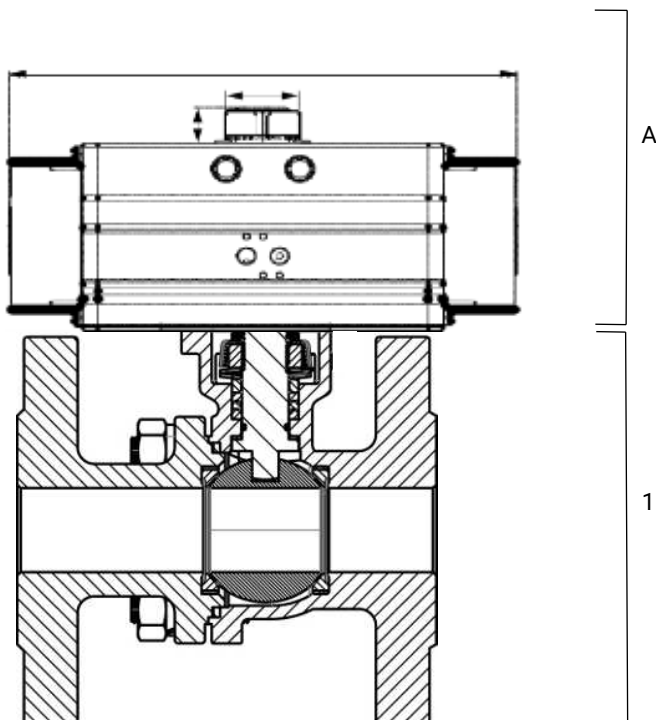

Item	Name	Order designation
1	Ball valve body assembly	BB0F
A	Actuator	See actuator designation, dependent on the actuator version

17 Removal from piping

1. Remove the clamp or screw connections in reverse order to installation.
2. Remove welded or solvent cemented connections using a suitable cutting tool.
3. Observe the safety information and accident prevention regulations.

18 Disposal

1. Pay attention to adhered residual material and gas diffusion from penetrated media.
2. Dispose of all parts in accordance with the disposal regulations/environmental protection laws.

19 Returns

Legal regulations for the protection of the environment and personnel require that the completed and signed return delivery note is included with the dispatch documents. Returned goods can be processed only when this note is completed. If no return delivery note is included with the product, GEMÜ cannot process credits or repair work but will dispose of the goods at the operator's expense.

1. Clean the product.
2. Request a return delivery note from GEMÜ.
3. Complete the return delivery note.
4. Send the product with a completed return delivery note to GEMÜ.

20 EU Declaration of Incorporation according to the EC Machinery Directive 2006/42/EC, Annex II B



EU Declaration of Incorporation

according to the EC Machinery Directive 2006/42/EC, Annex II B

We, the company GEMÜ Gebr. Müller Apparatebau GmbH & Co. KG
Fritz-Müller-Strasse 6-8
74653 Ingelfingen-Criesbach, Germany

hereby declare under our sole responsibility that the below-mentioned product complies with the relevant essential health and safety requirements in accordance with Annex I of the above-mentioned Directive.

Product: GEMÜ B4F
Product name: Pneumatically operated 2/2-way ball valve
The following essential health and safety requirements of the EC Machinery Directive 2006/42/EC, Annex I have been applied or adhered to: 1.1.2.; 1.1.3.; 1.1.5.; 1.3.2.; 1.3.3.; 1.3.4.; 1.3.7.; 1.3.8.; 1.5.13.; 1.5.3.; 1.5.5.; 1.5.6.; 1.5.7.; 1.5.8.; 1.6.1.; 1.6.3.; 1.6.5.; 1.7.1.; 1.7.1.1.; 1.7.2.; 1.7.3.; 1.7.4.; 1.7.4.1.; 1.7.4.2.; 1.7.4.3.
The following harmonized standards (or parts thereof) have been applied: EN ISO 12100:2010

We also declare that the specific technical documents have been created in accordance with part B of Annex VII.

The manufacturer undertakes to transmit relevant technical documents on the partly completed machinery to the national authorities in response to a reasoned request. This communication takes place electronically.

This does not affect the industrial property rights.

The partly completed machinery may be commissioned only if it has been determined, if necessary, that the machinery into which the partly completed machinery is to be installed meets the provisions of the Machinery Directive 2006/42/EC.

M. Barghoorn
Head of Global Technics

Ingelfingen, 23/01/2024

21 EU Declaration of Conformity in accordance with 2014/68/EU (Pressure Equipment Directive)



EU Declaration of Conformity

in accordance with 2014/68/EU (Pressure Equipment Directive)

We, the company GEMÜ Gebr. Müller Apparatebau GmbH & Co. KG
Fritz-Müller-Strasse 6-8
74653 Ingelfingen-Criesbach, Germany

hereby declare under our sole responsibility that the below-mentioned product complies with the regulations of the above-mentioned Directive.

Product: GEMÜ B4F
Product name: Pneumatically operated 2/2-way ball valve
Notified body: TÜV Rheinland Industrie Service GmbH
Am Grauen Stein 1
51105 Cologne, Germany
ID number of the notified body: 0035
No. of the QA certificate: 01 202 926/Q-02 0036
Conformity assessment procedure(s) applied: Module H
The following harmonized standards (or parts thereof) have been applied: EN ISO 1983:2013

Information for products with a nominal size \leq DN 25:

The products are developed and produced according to GEMÜ's in-house process instructions and standards of quality which comply with the requirements of ISO 9001 and ISO 14001. According to Article 4, Paragraph 3 of the Pressure Equipment Directive 2014/68/EU, these products must not be identified by a CE-marking.

Other applied technical standards / Remarks:

- DIN EN ISO 5211; DIN EN 558

M. Barghoorn
Head of Global Technics
Ingelfingen, 23/01/2024



GEMÜ Gebr. Müller Apparatebau GmbH & Co. KG
Fritz-Müller-Straße 6-8, 74653 Ingelfingen-Criesbach, Germany
Phone +49 (0) 7940 1230 · info@gemue.de
www.gemu-group.com

Subject to alteration

06.2024 | 88887626